

Welcome to Putzmeister Industrial Technology Pulsation Dampening Systems

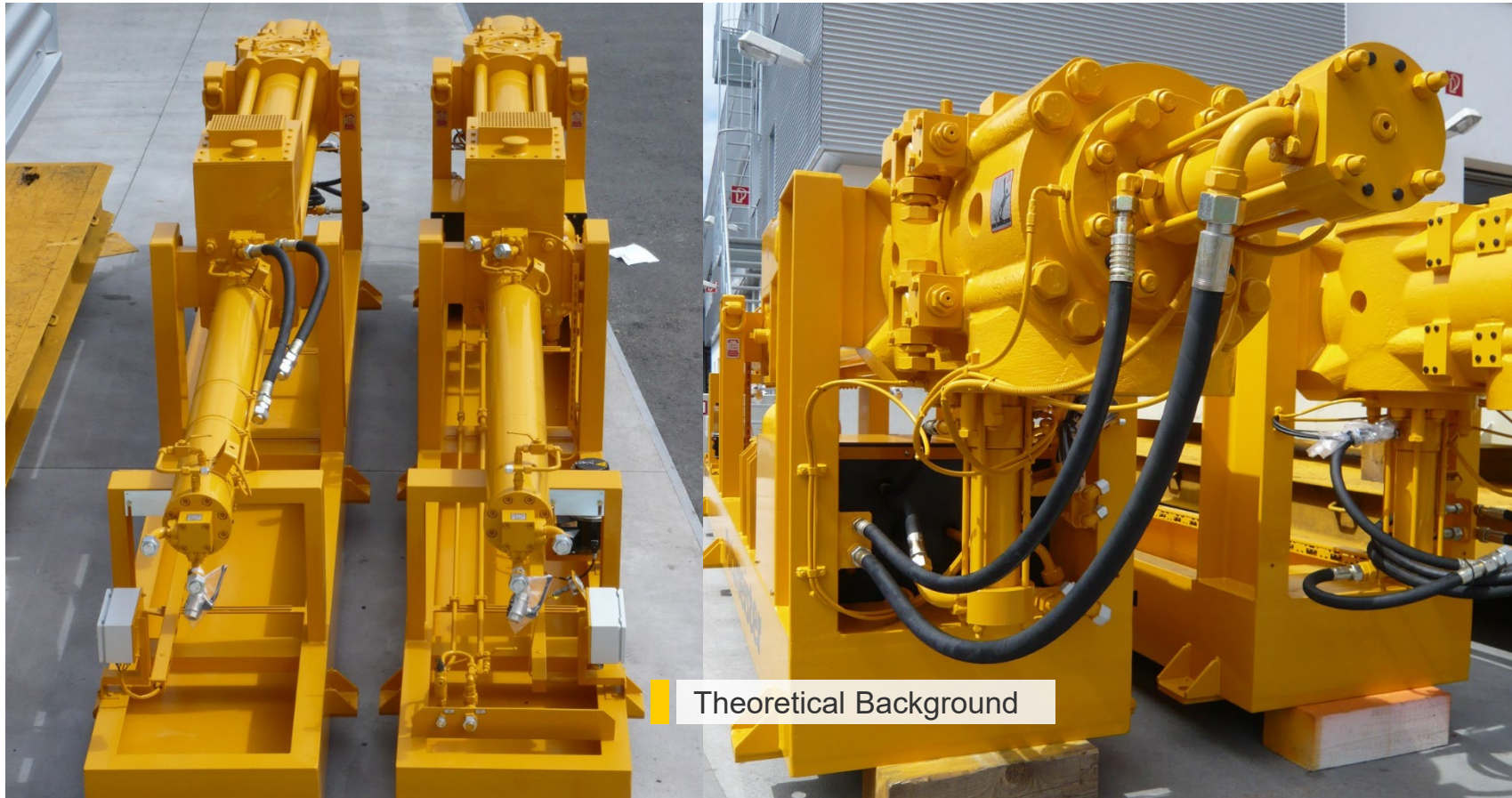



Theoretical Background

Liquid and pasty material are “nearly noncompressible”, because of their water content.

→ The compression factor of water at ambient Temperature is 0,0000034 at one pound pressure. This density and relatively low compressibility are turning out to be a good medium for generating and transmission of shock waves.

Due to the technical construction of a volumetric pump, material will be compressed under pressure. As soon as the pump is switching form one pressure chamber to the other, variation of the delivery pressure will occur.

This variation in pressure (Dp) is creating pressure waves (similar to waves of sound), which is a kind of energy as the conservation of energy is a basic fundamental law of Physics.

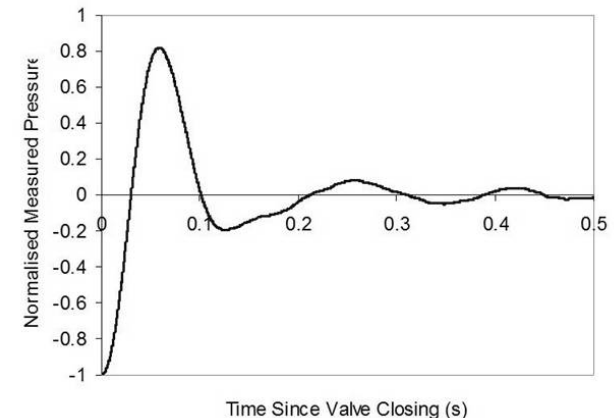

Waterhammer occurs when an abrupt change in flow creates shock waves that travel back and forth the pumping material.

How does the Water Hammer occur at PD Pumps?

As the pressure drops quickly during the change over process, the material in the pipeline sees an immediate drop in pressure and the static water column (and the dissolved air) expands slightly from its compressed state.

This is creating a pressure wave which is traveling upstream the pipeline. When this wave hits an upstream interference (valve, elbow etc.), the wave will be reflected like an “echo”.

Because of the fast change-over of a PD- pump, the pump delivers material again into the pipeline increases its pressure.

If the pressure increase is very quickly, the forward material column (or its pressure wave) acts as a primary barrier which can create a water hammer as soon as the ongoing pressure wave hits its “echo” which is coming back from the pressure decrease.

→ The bigger the variance in pressure drop, the higher influence has the “Waterhammer”

Important Note:

**Putzmeister Piston Pumps are designed to be operated
without any Pulsation Dampening Device
as long as the delivery Pipeline is designed for a PD Pump.**

This is proven various times in industrial applications all over the world.

Nevertheless some applications are requesting a Putzmeister Pulsation Dampening Systems. Reasons for this request are:

- **Elimination of Waterhammers**
- **Expanding the lifetime** of the pipeline as the wall thickness can be smaller
- The Production Process requires a continuous flow of material
- **Lower noise** emission by the pipeline and therefore environmental friendly
- Pipeline Supports can be minimized

KOS



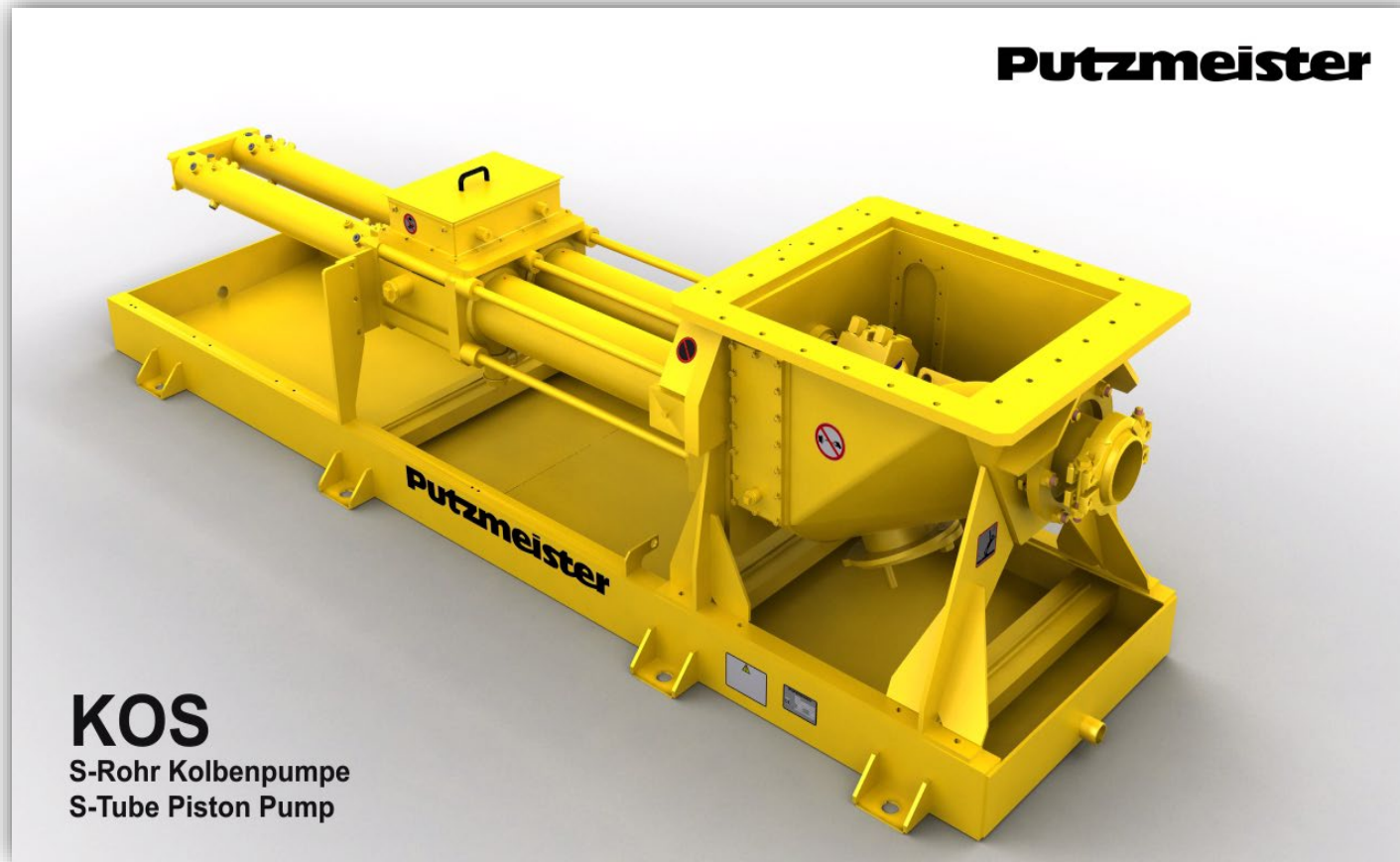

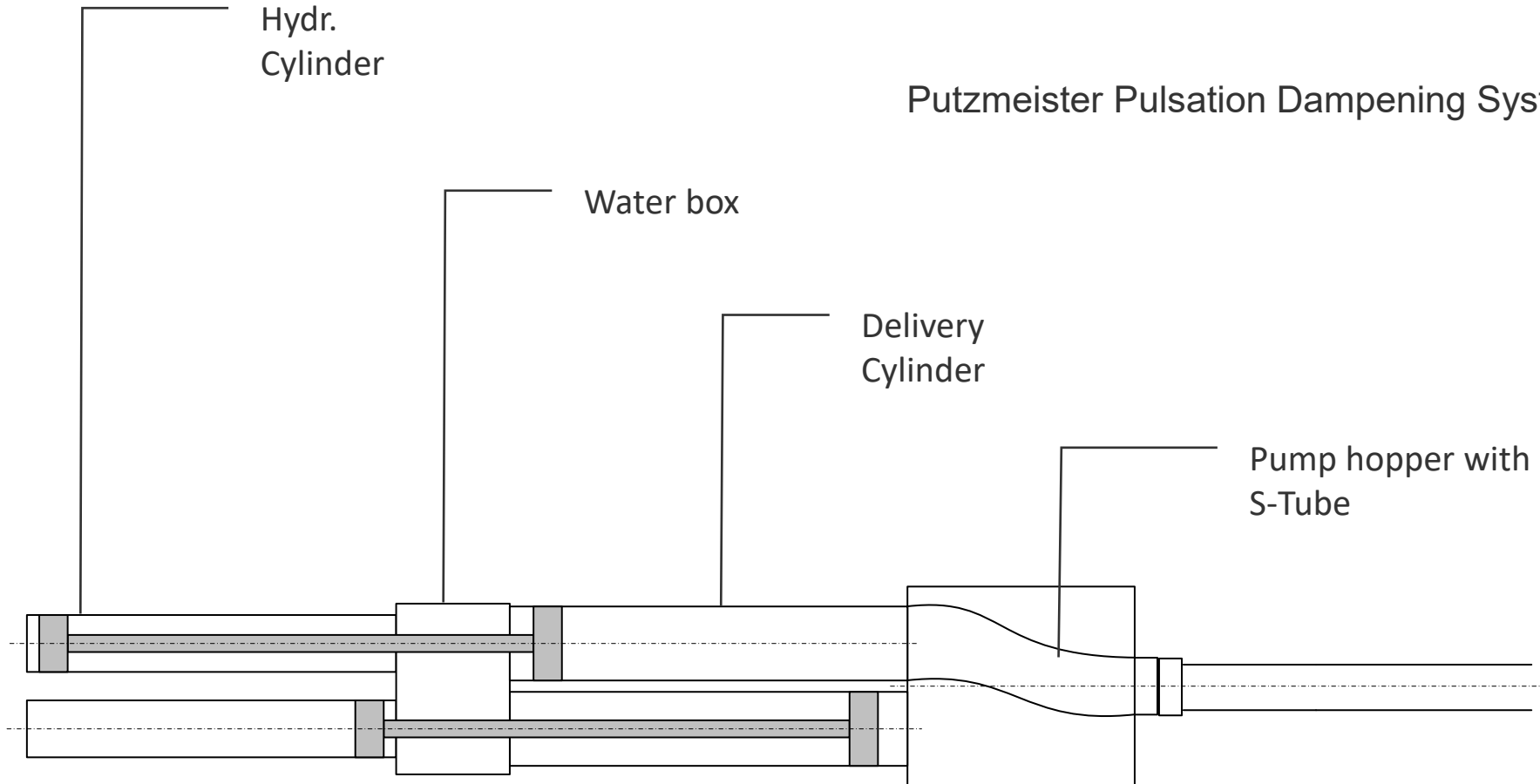

Putzmeister Pulsation Dampening Systems

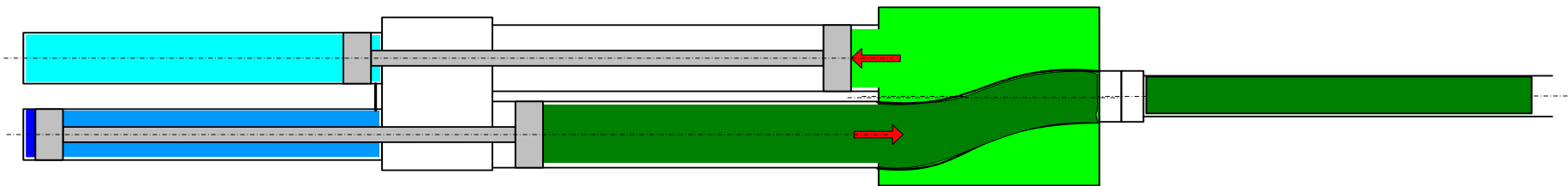
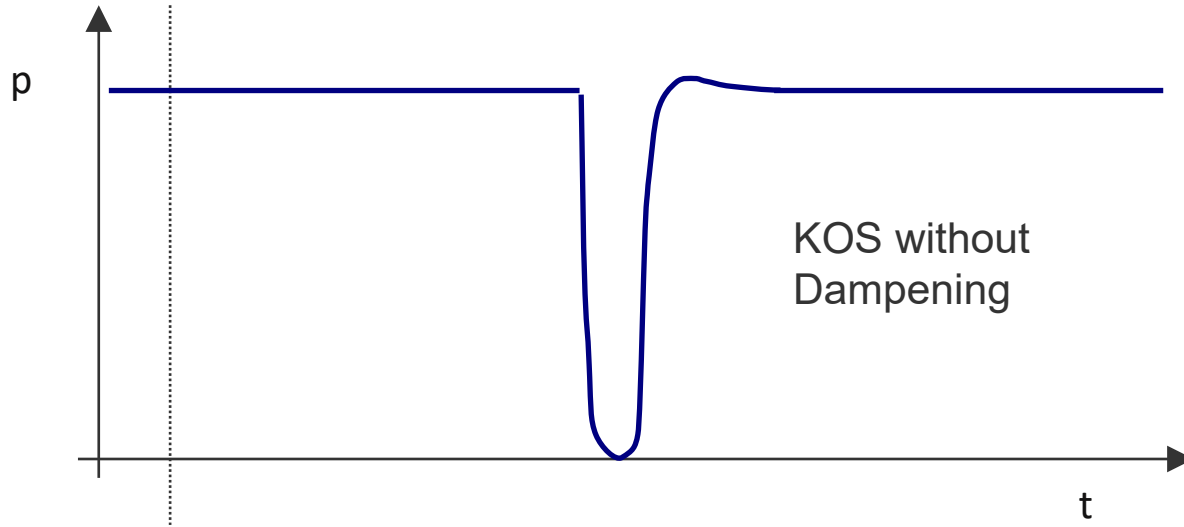

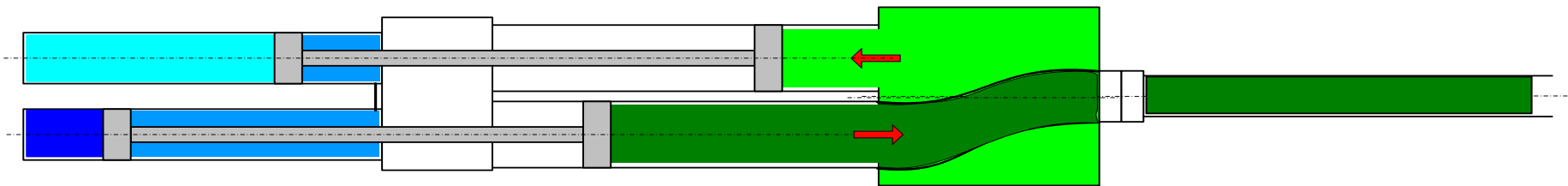
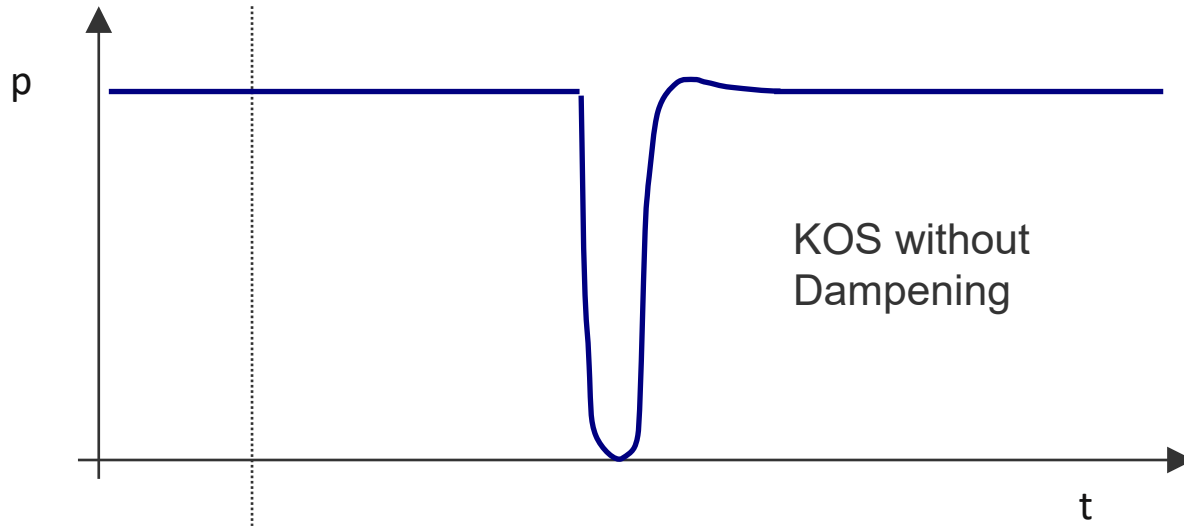

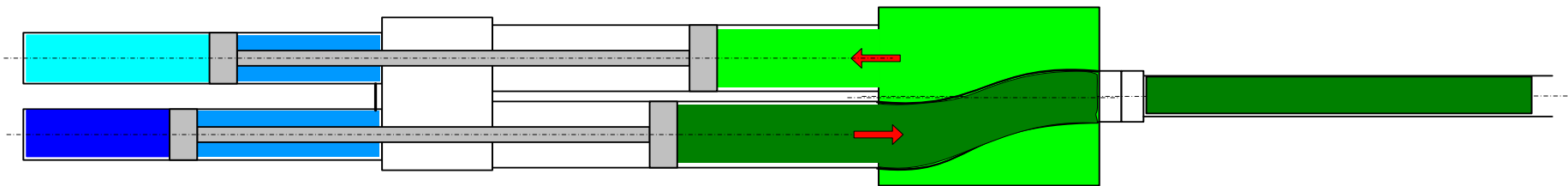
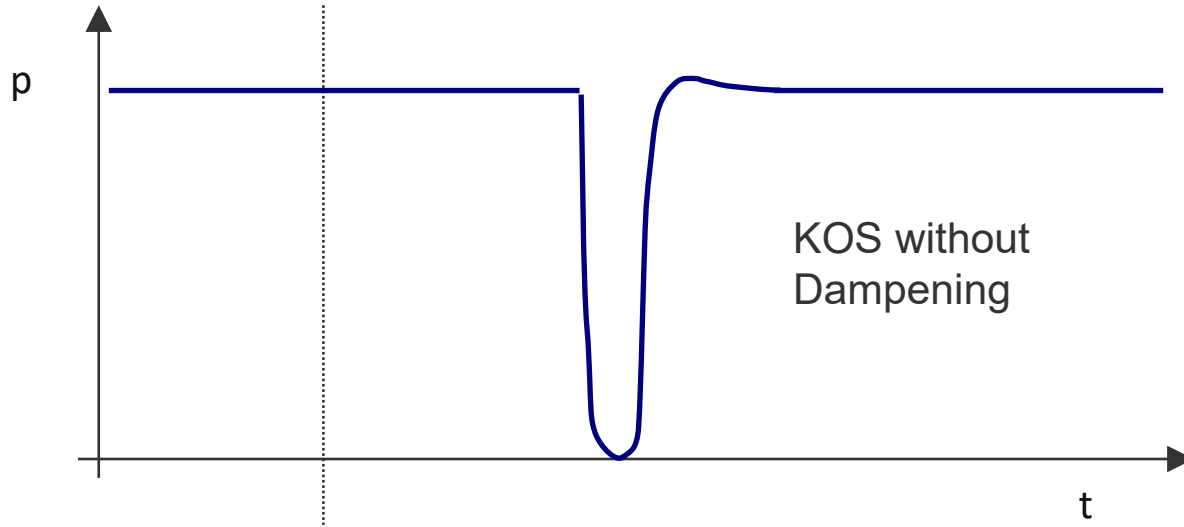

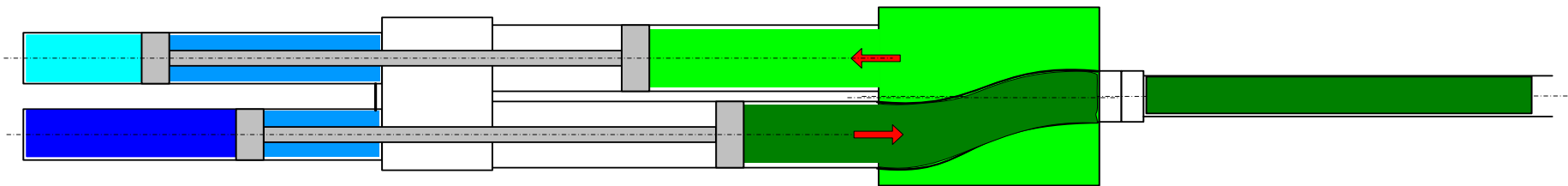
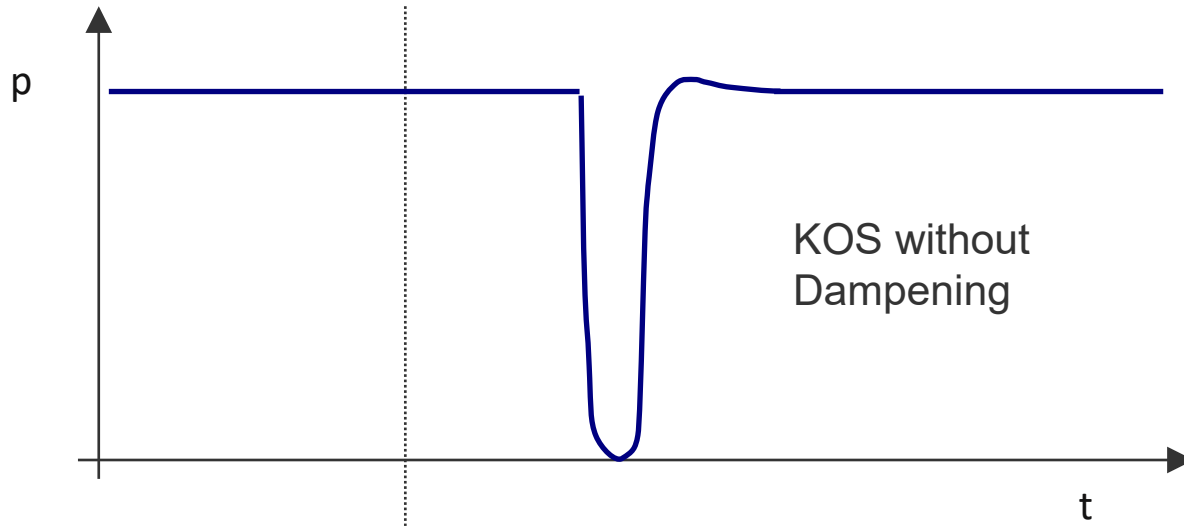

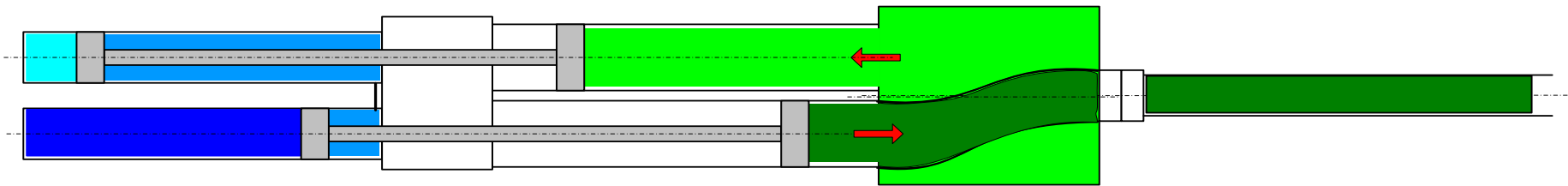
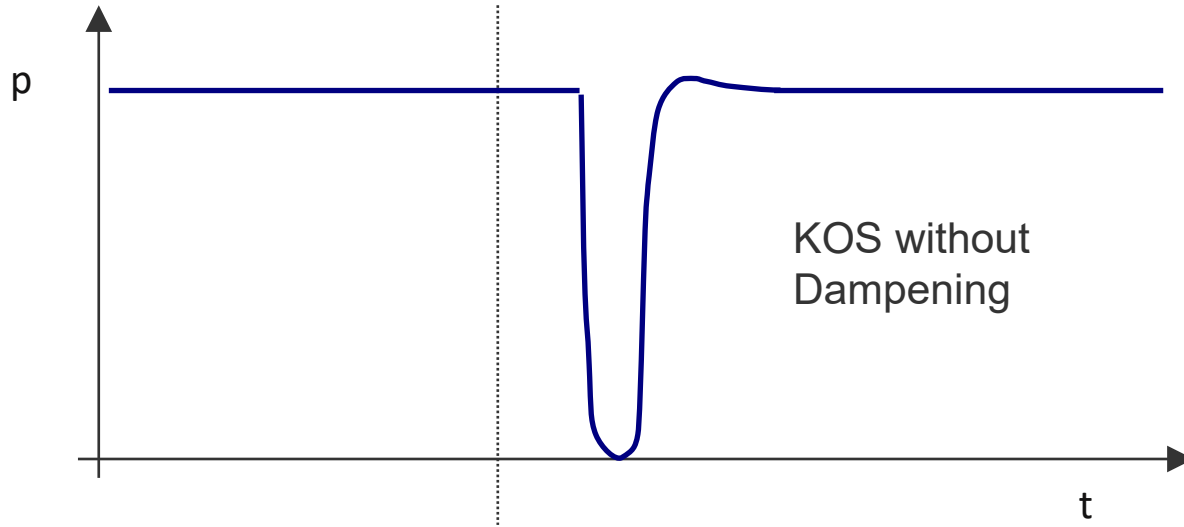

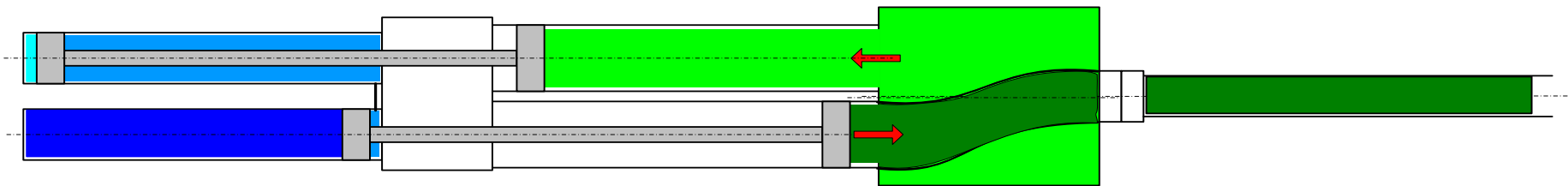
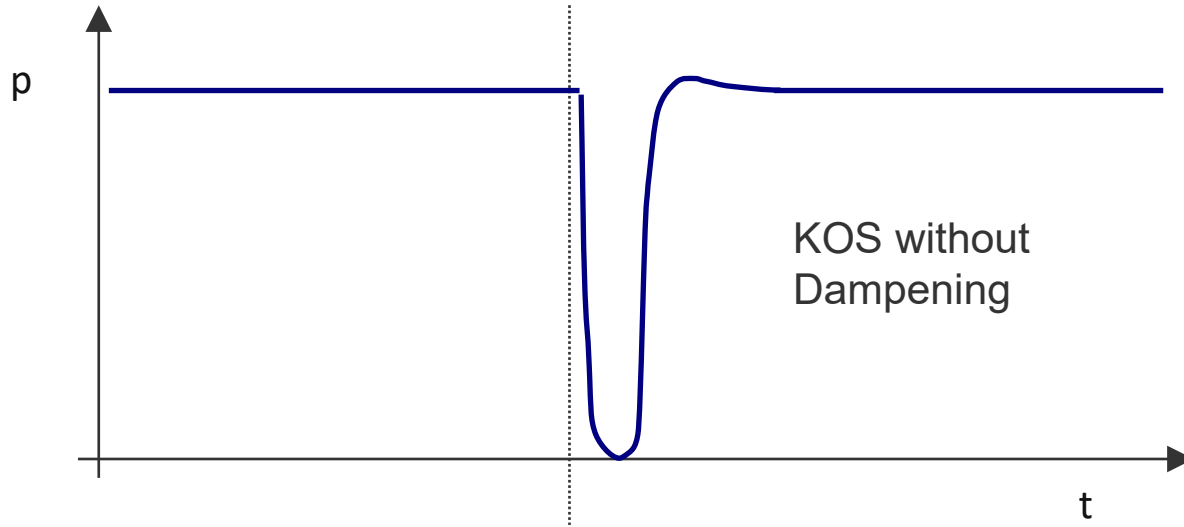

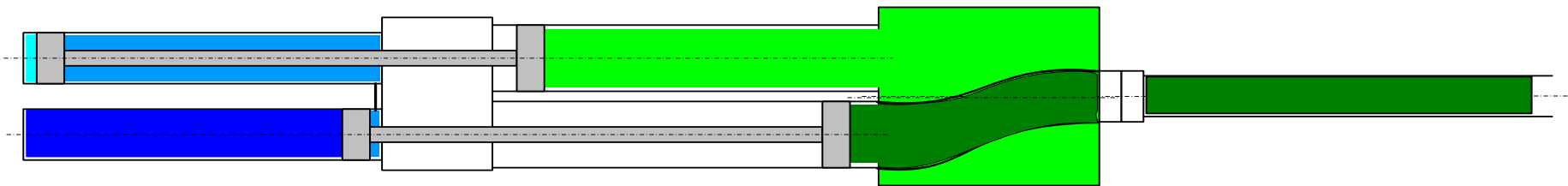
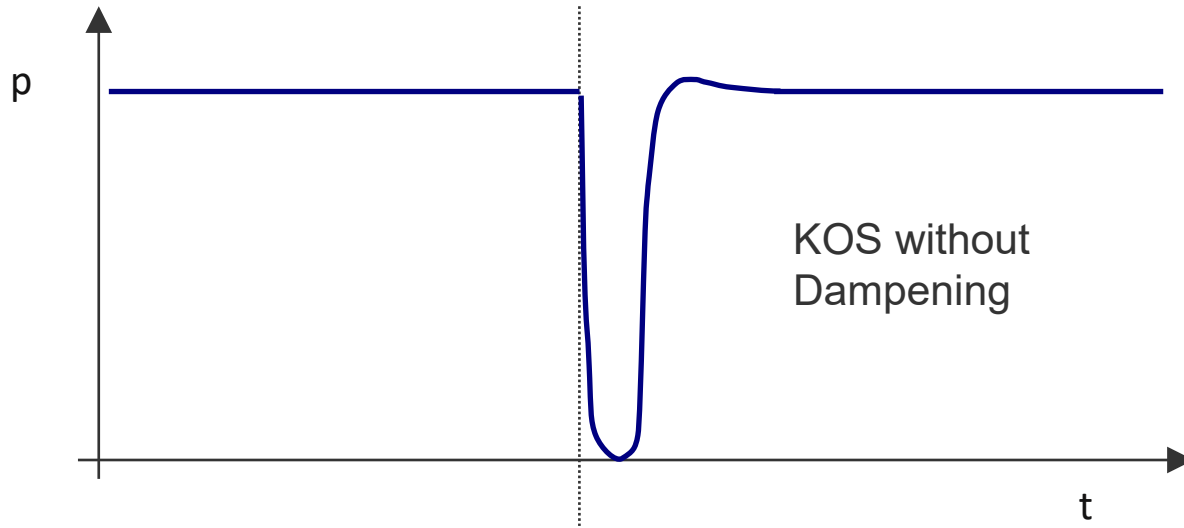

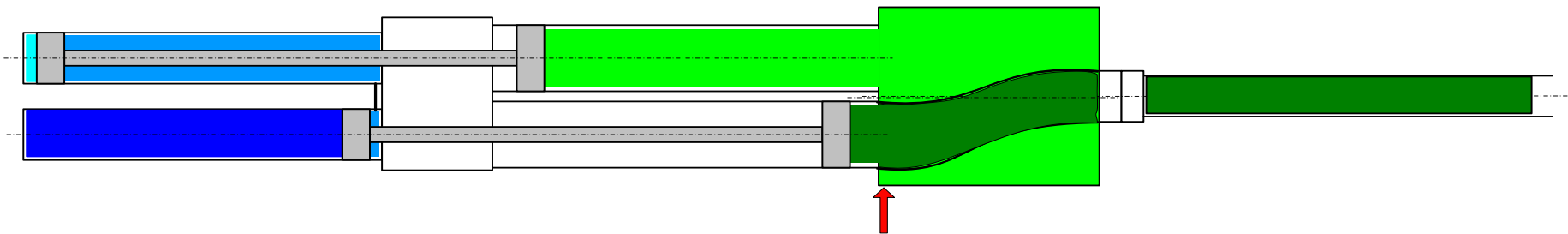
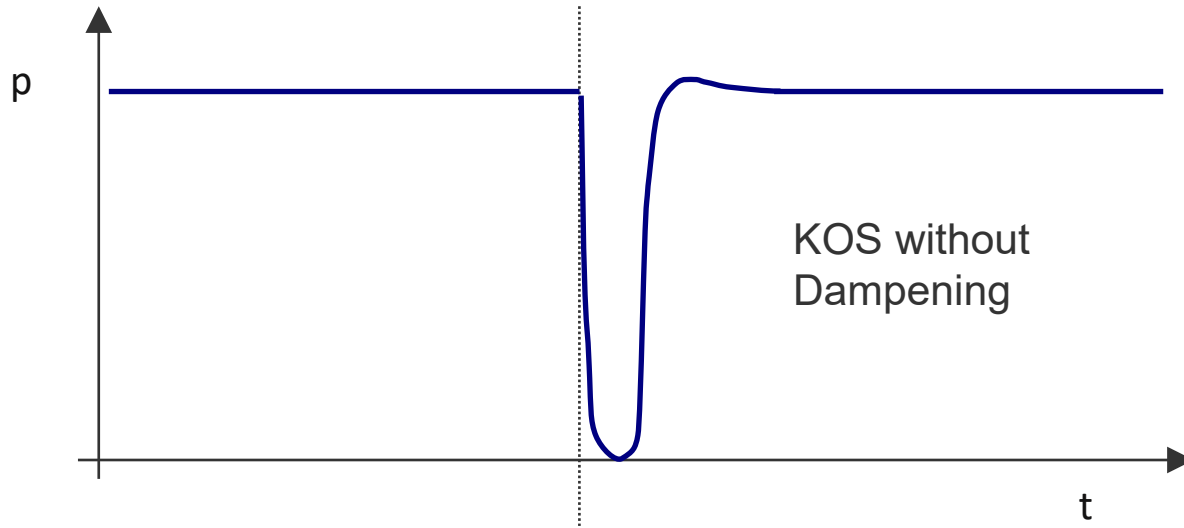

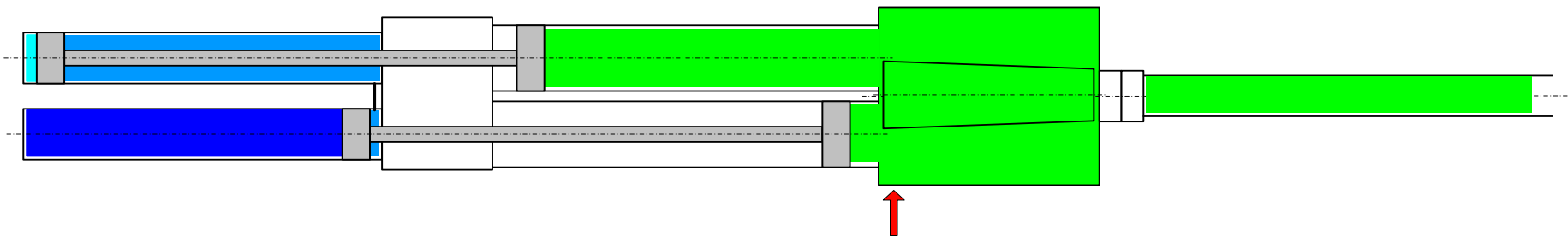
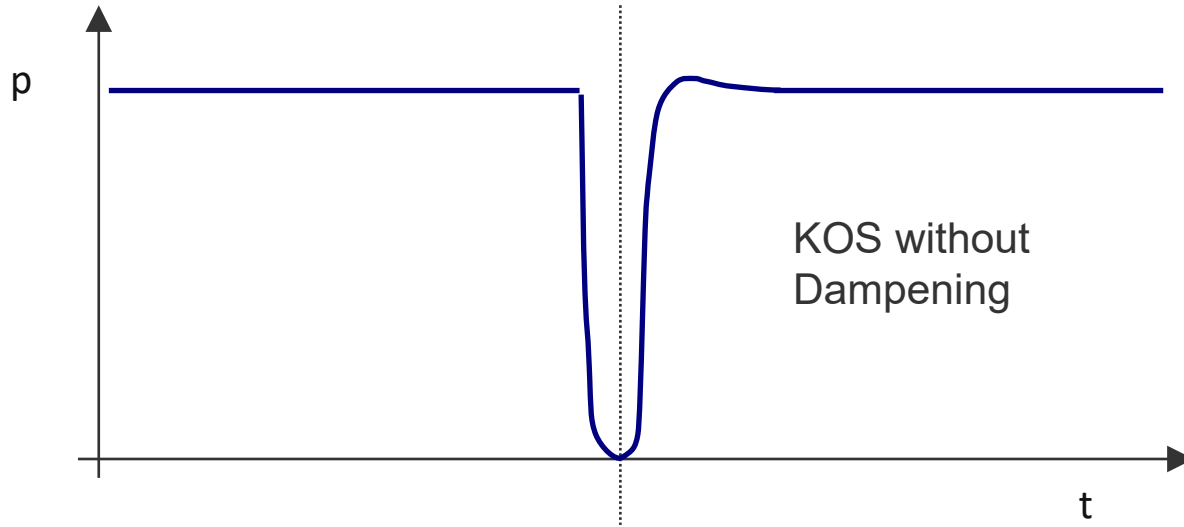

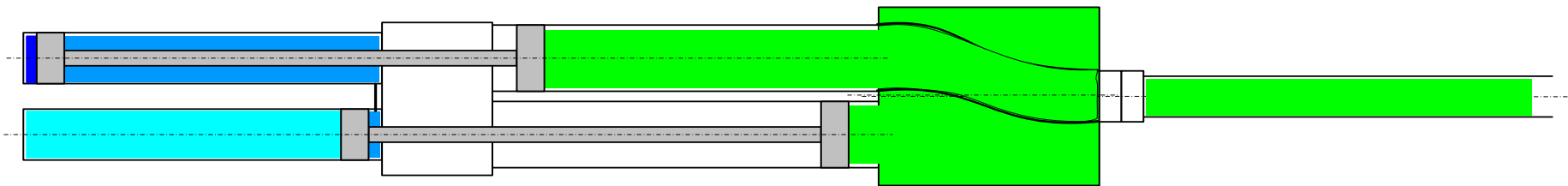
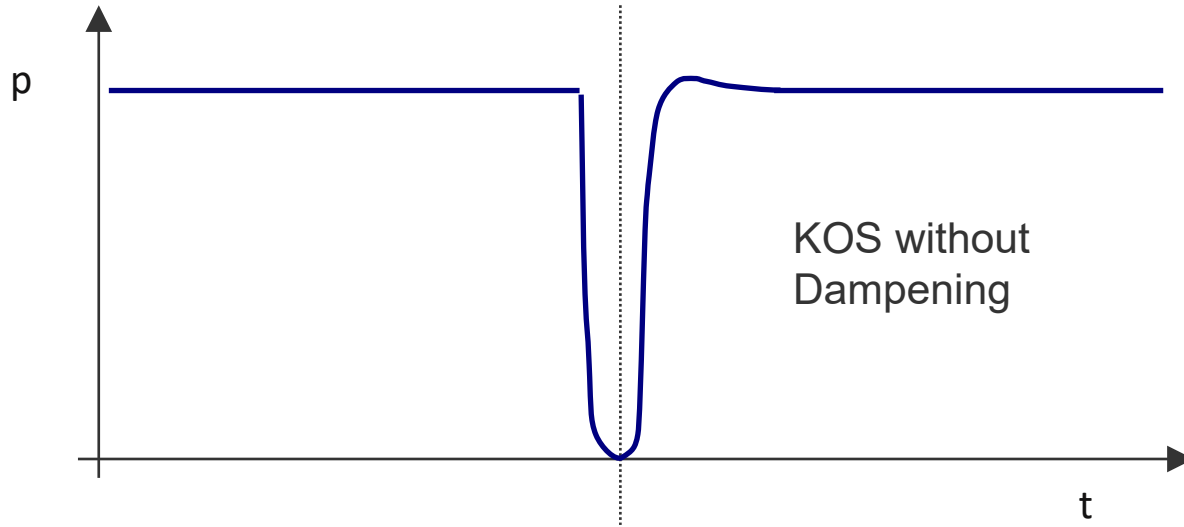

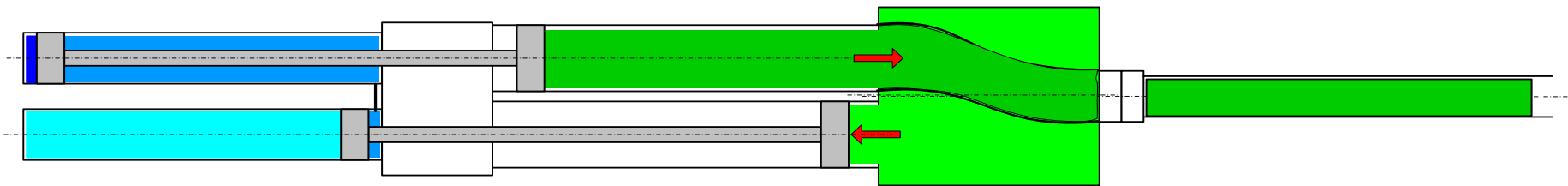
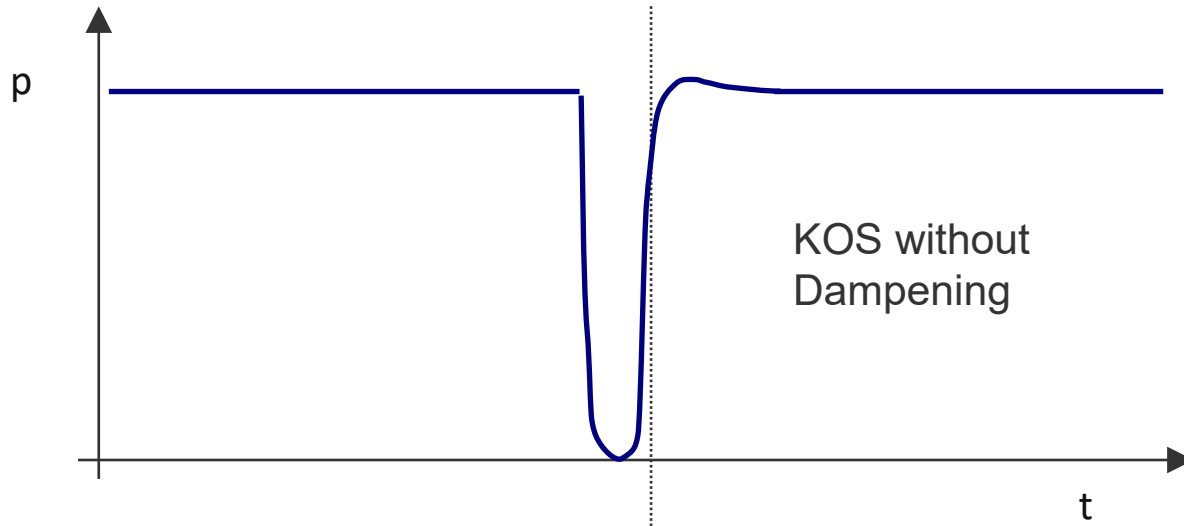

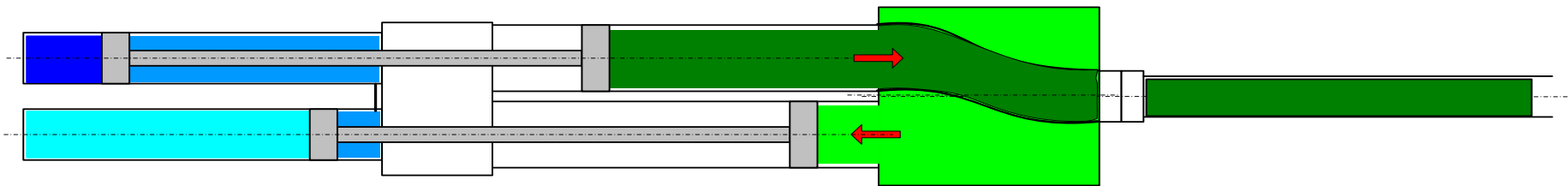
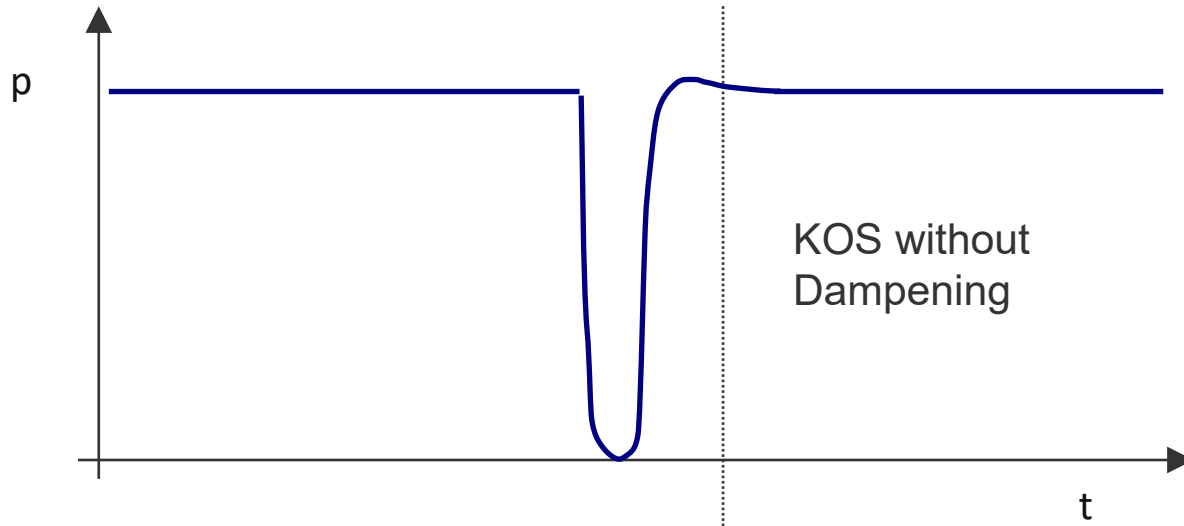

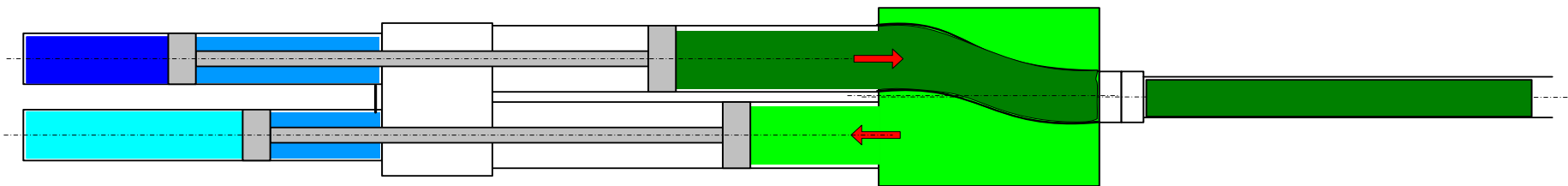
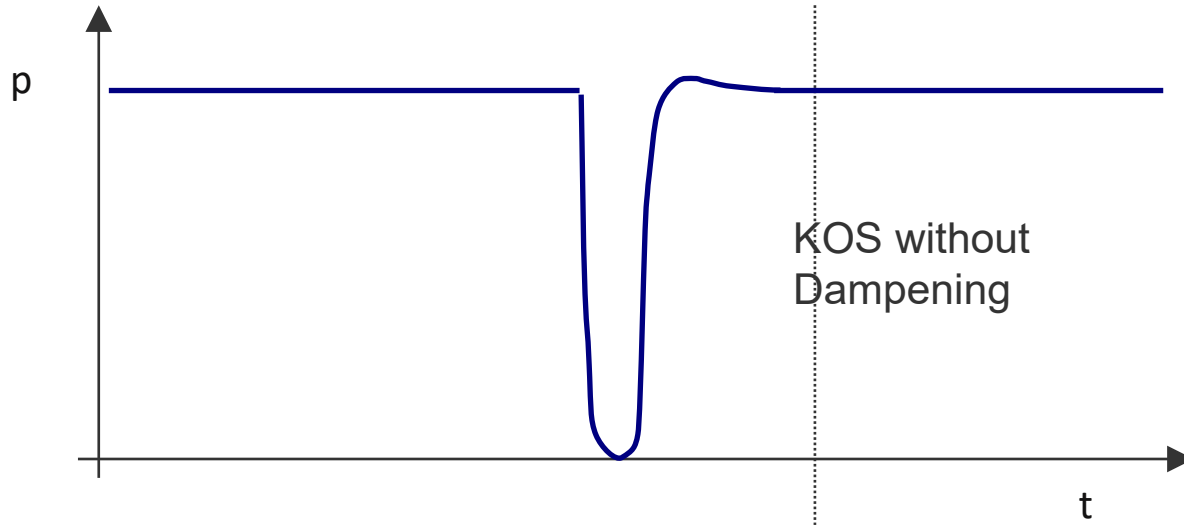

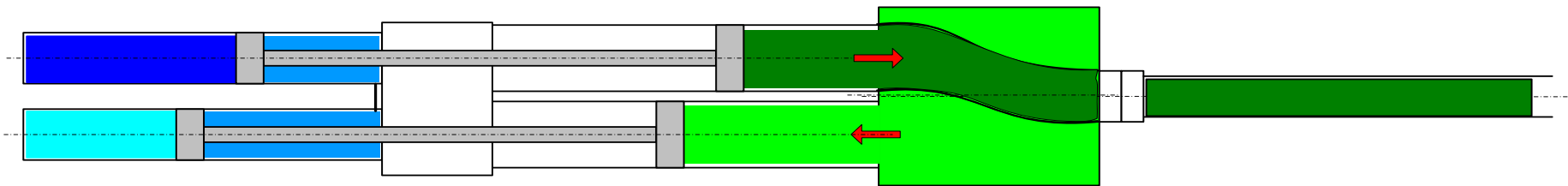
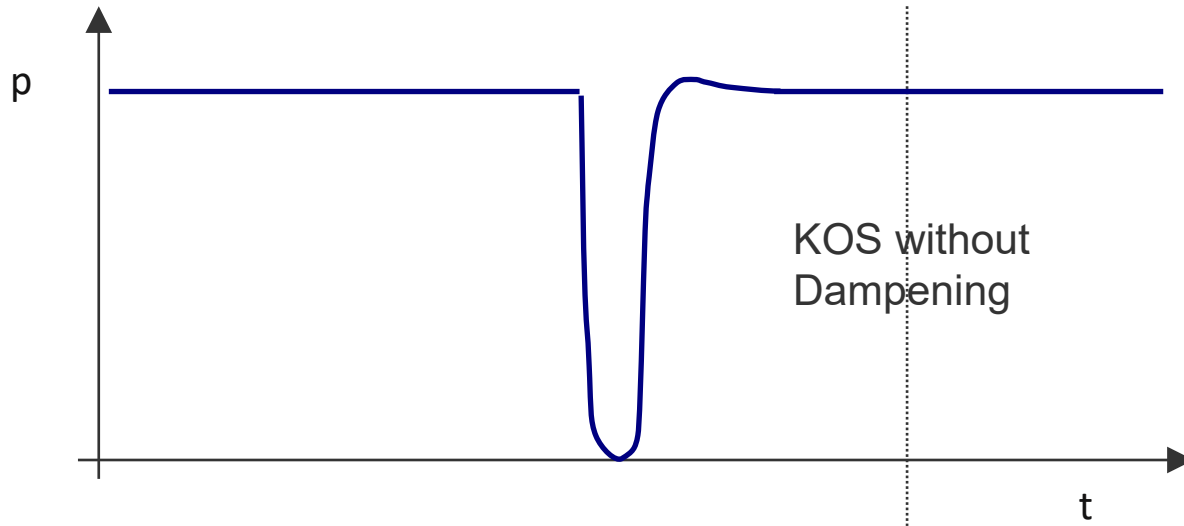

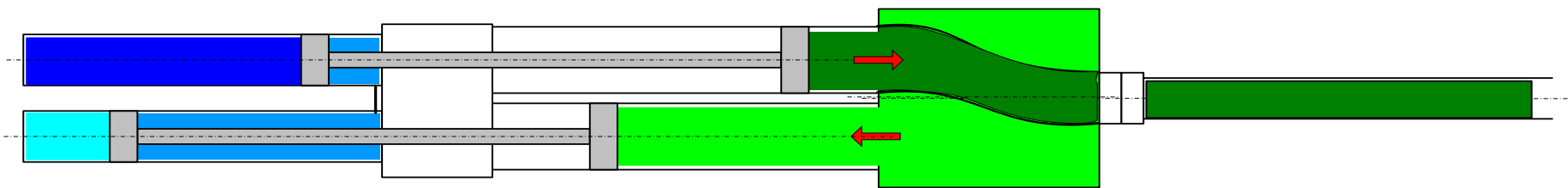
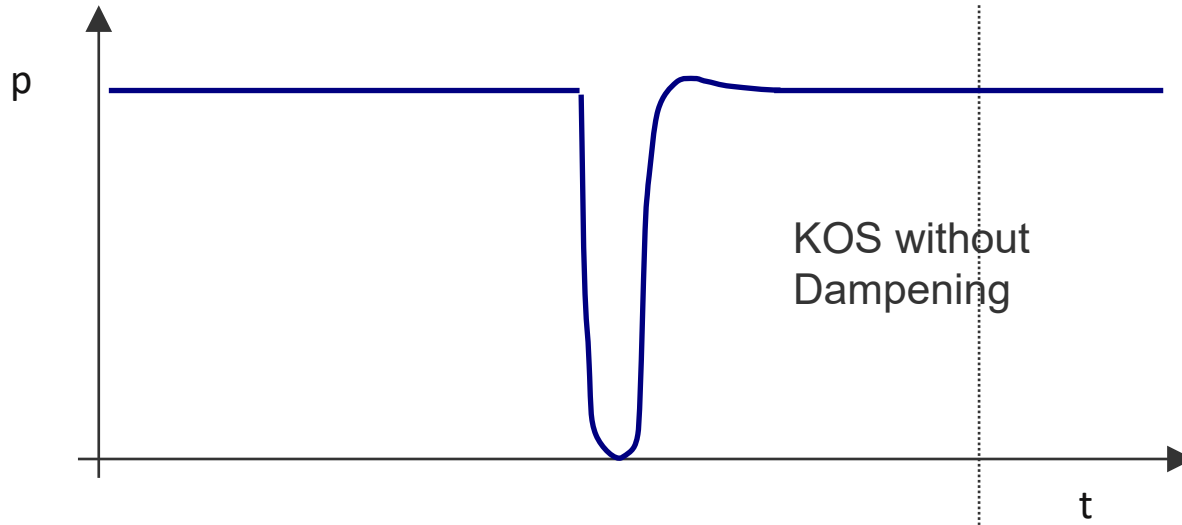

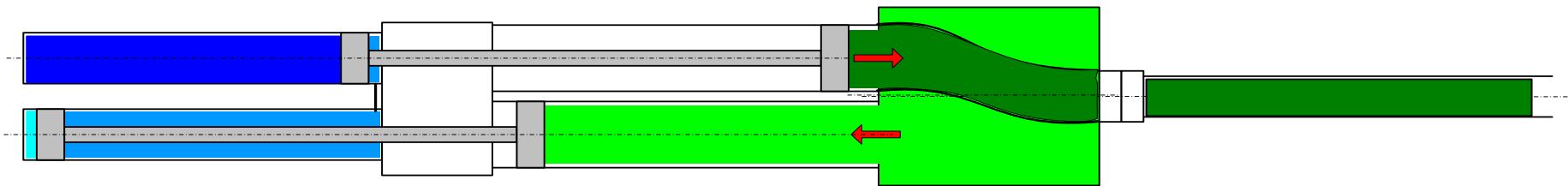
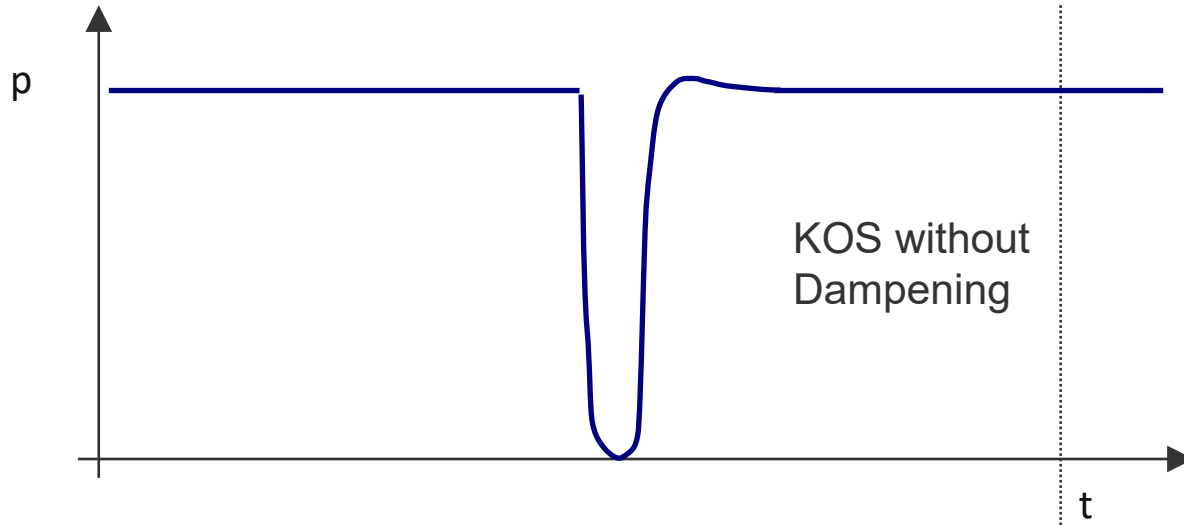

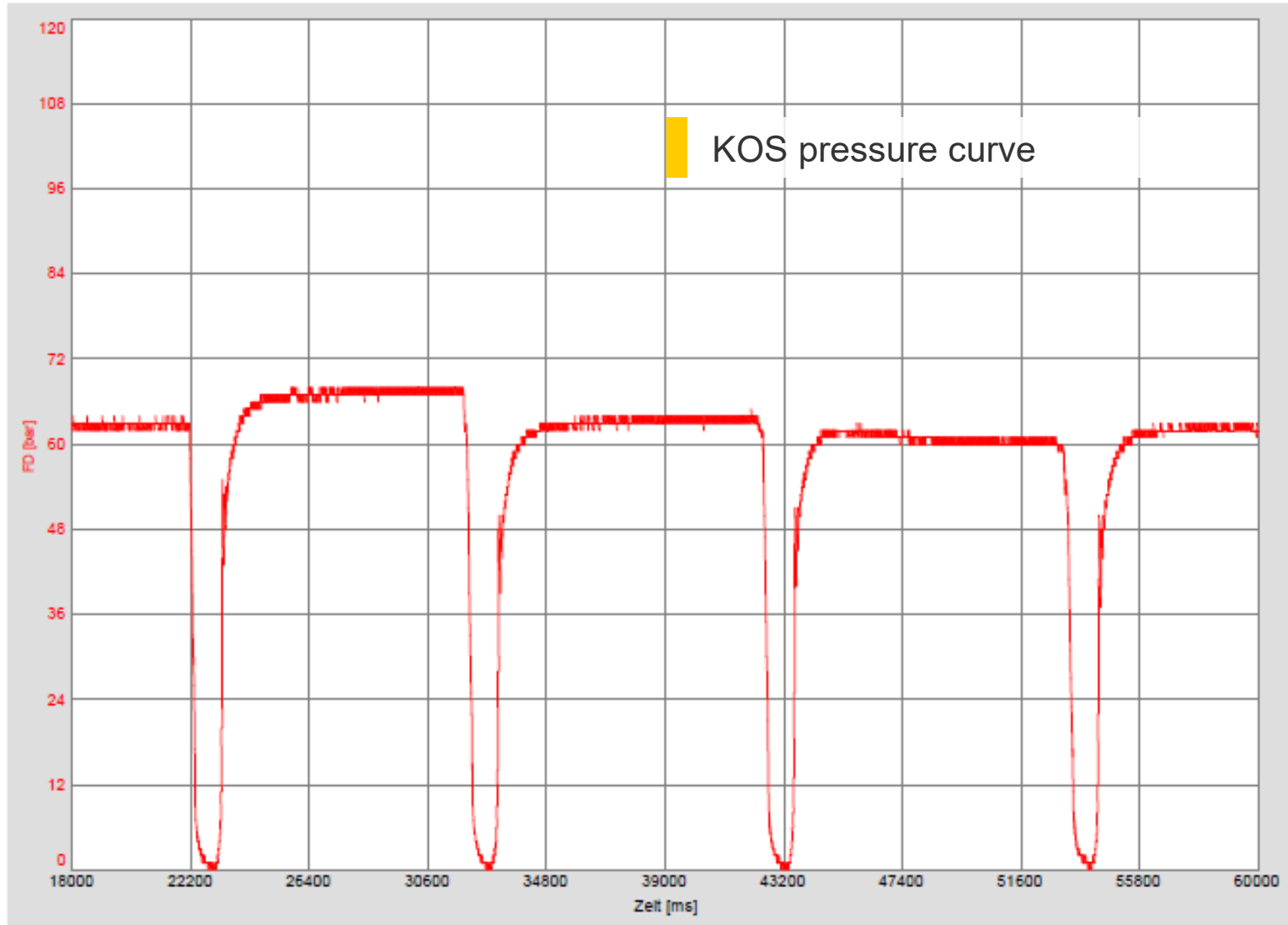

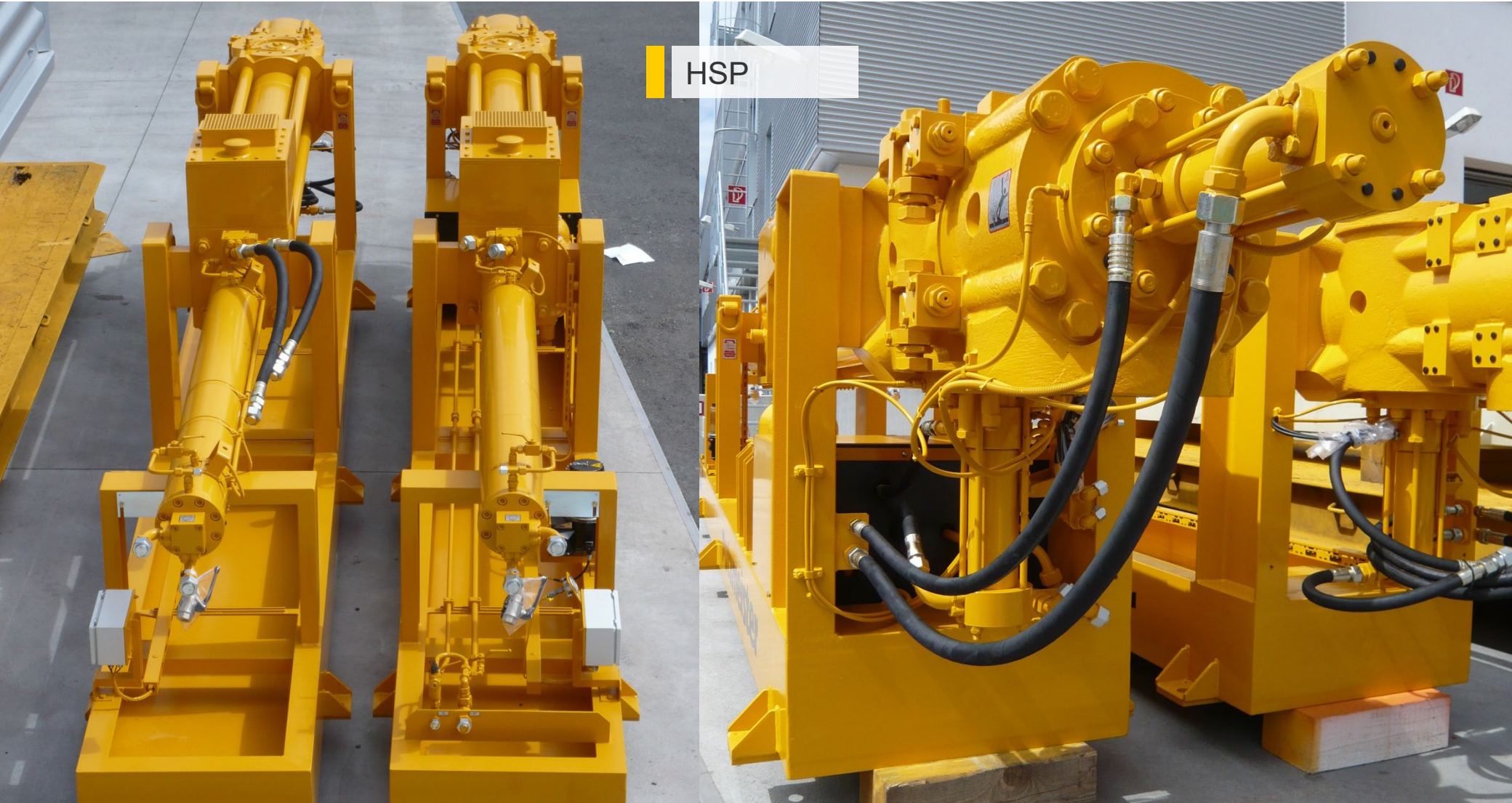

HSP

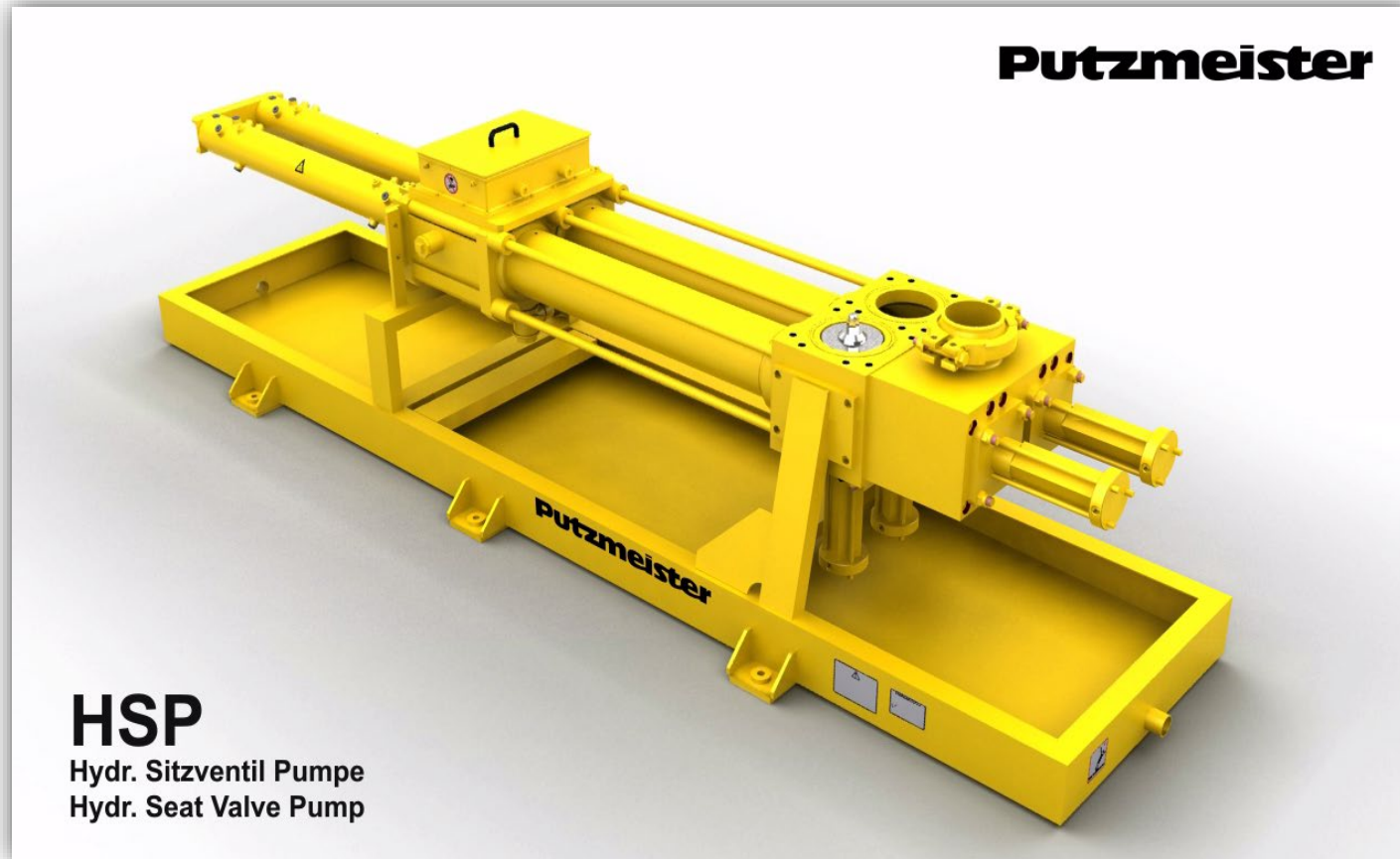

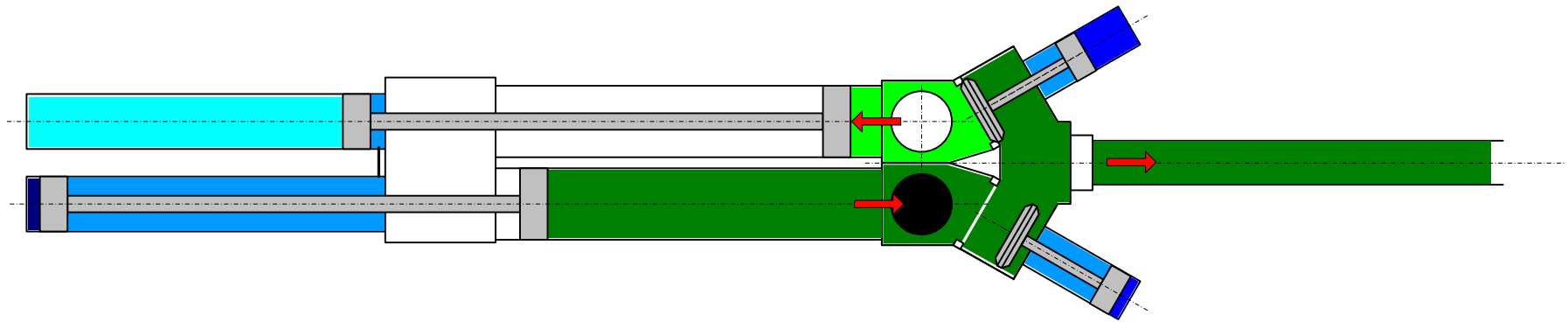
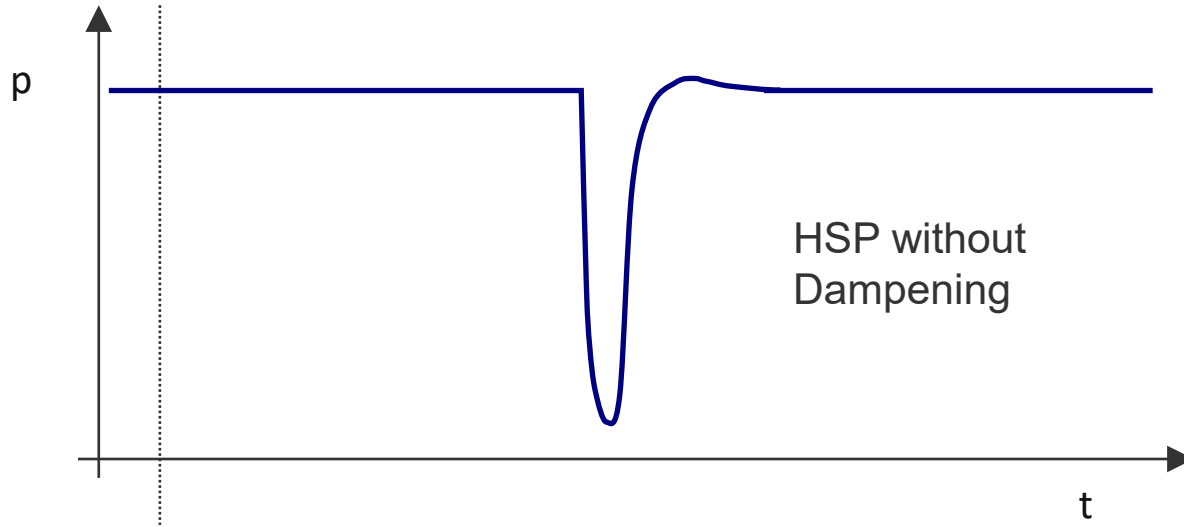

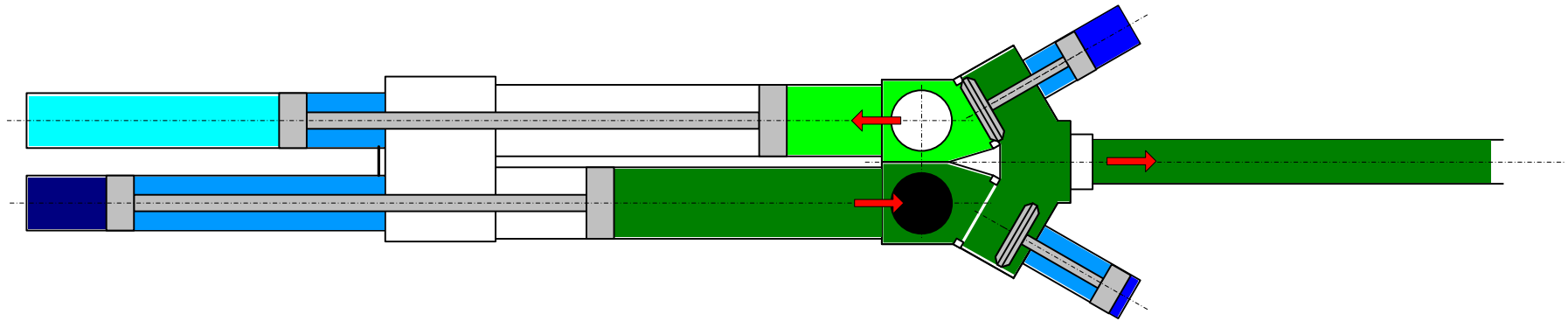
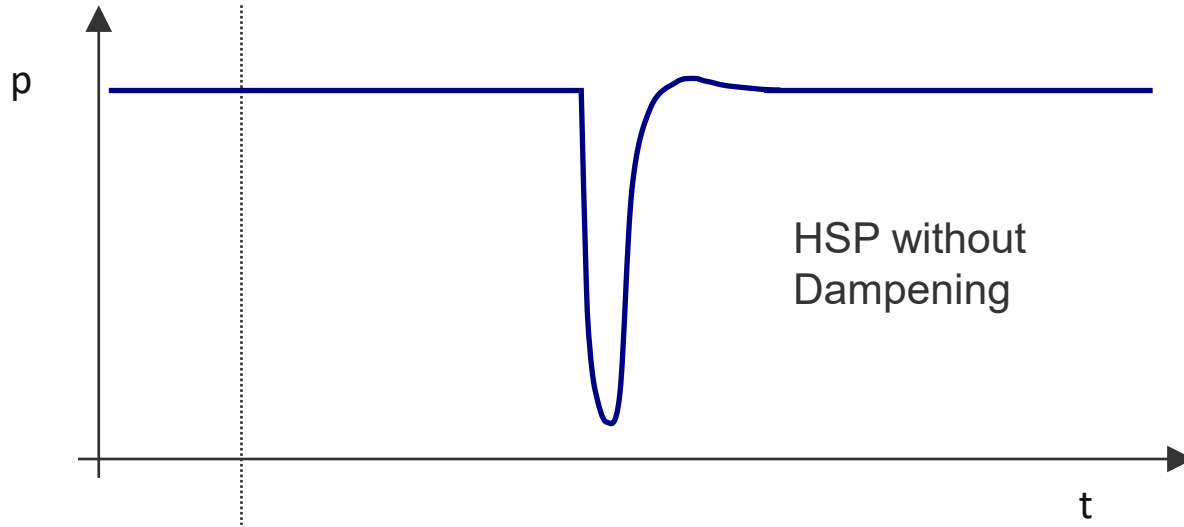

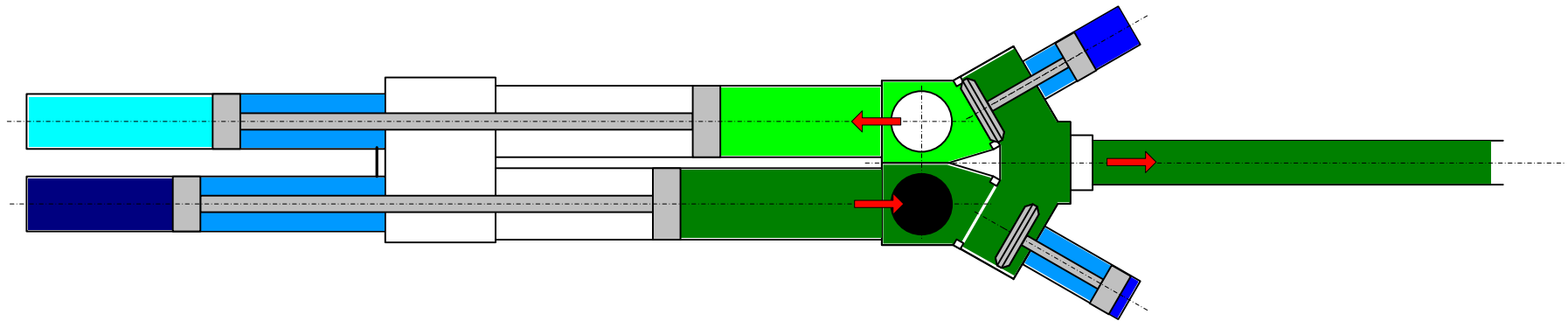
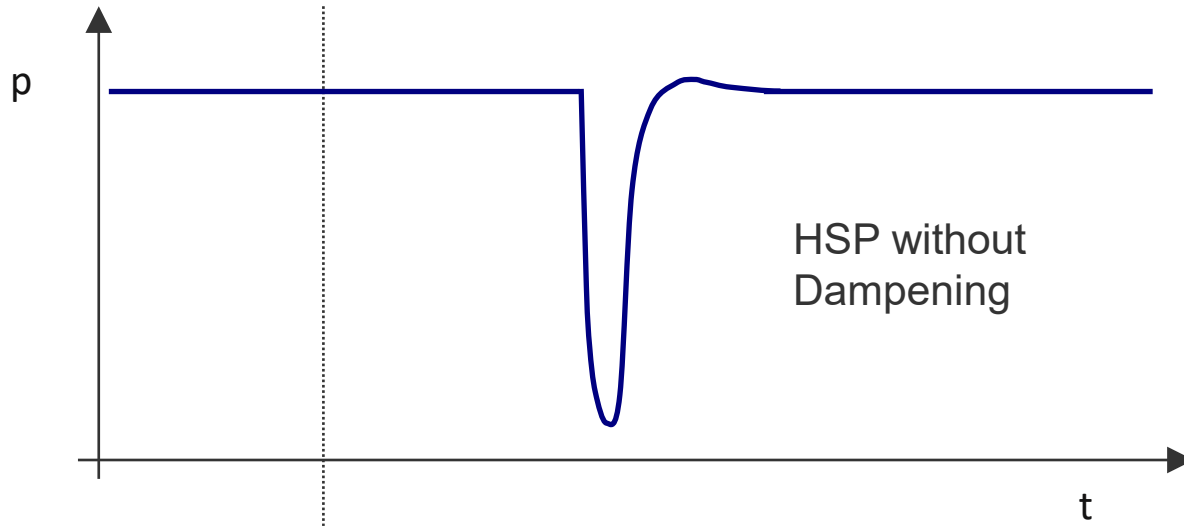

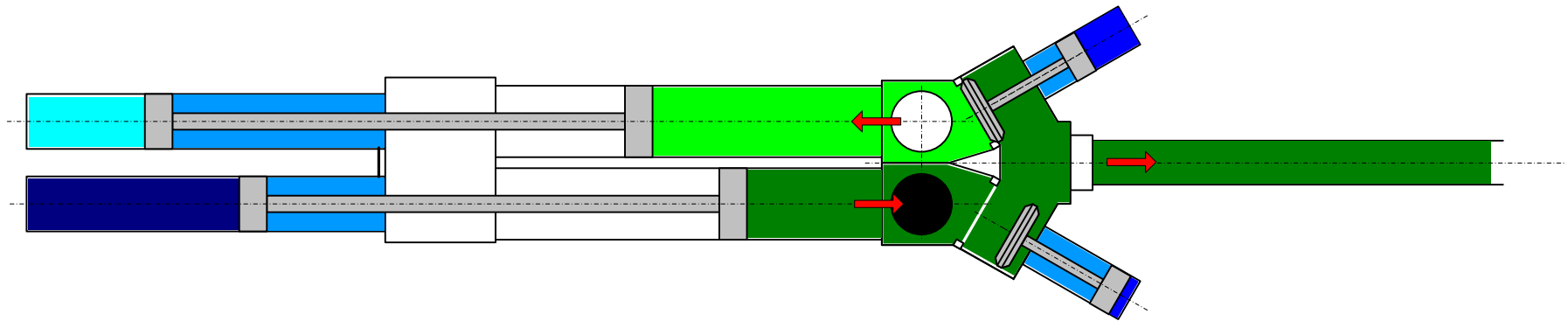
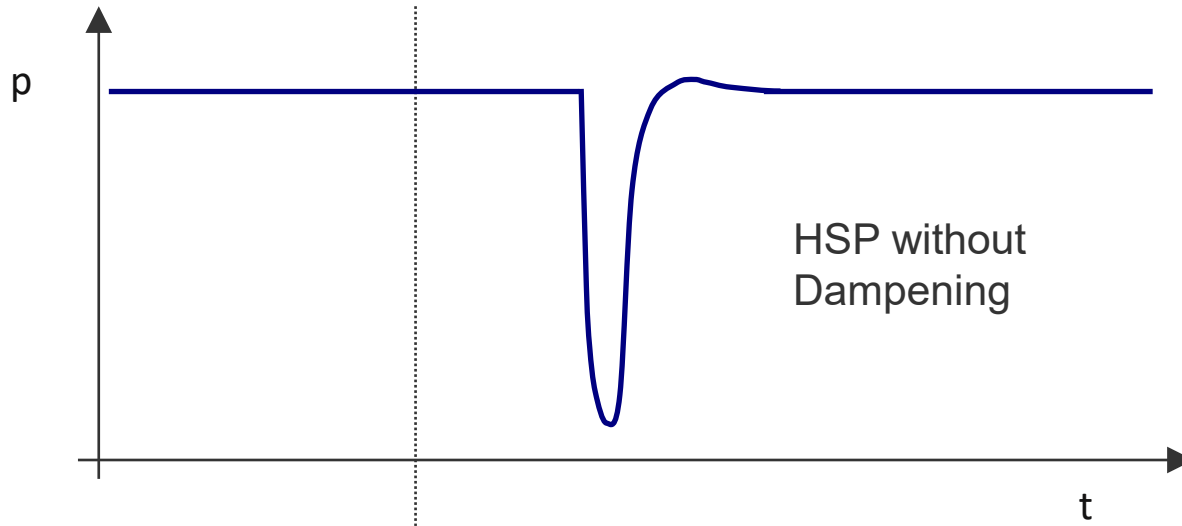

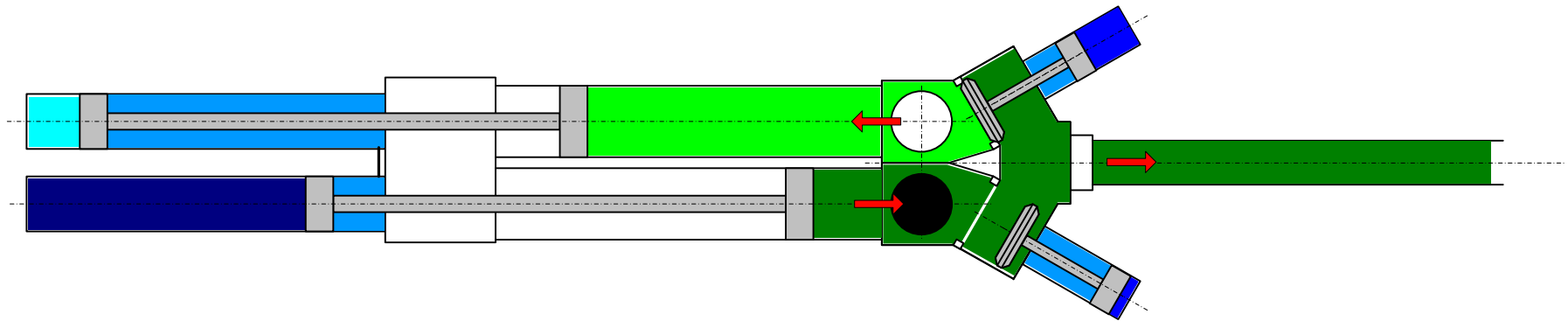
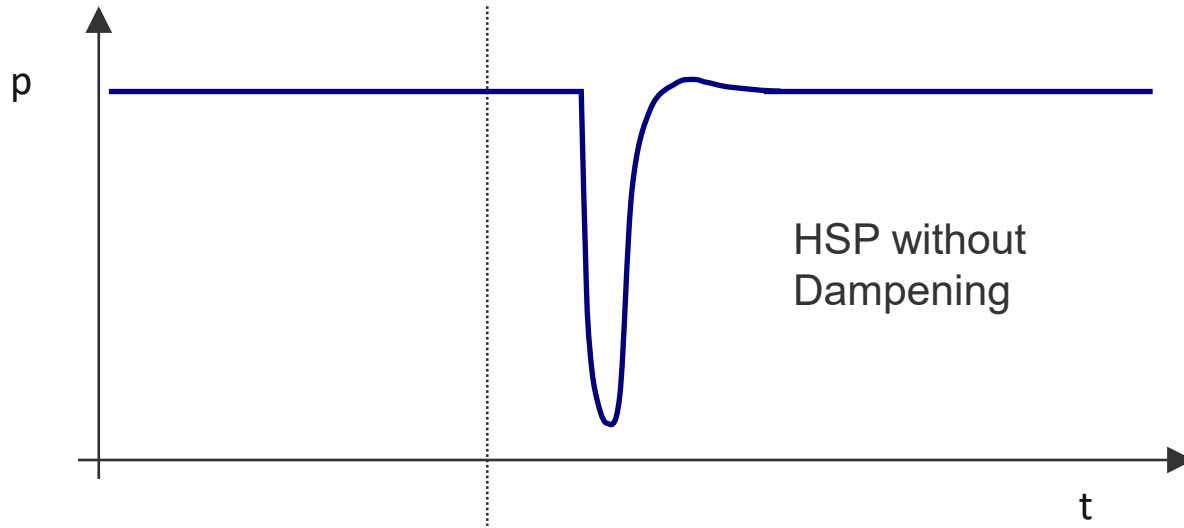

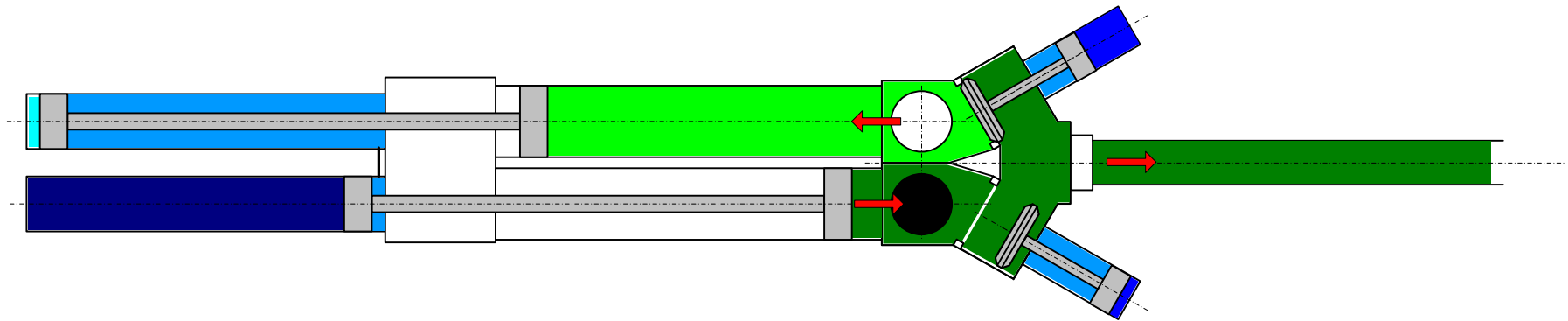
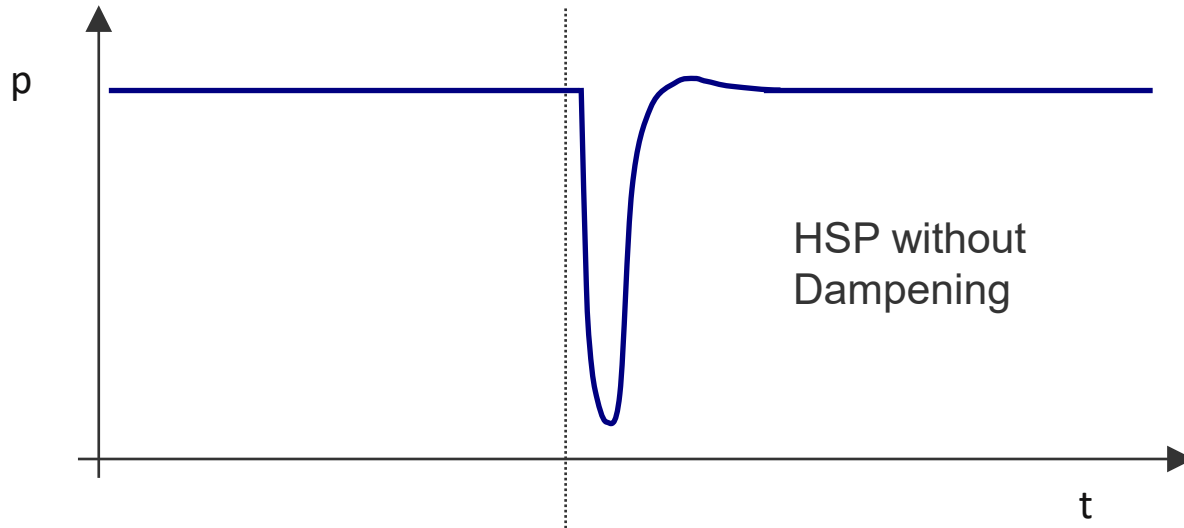

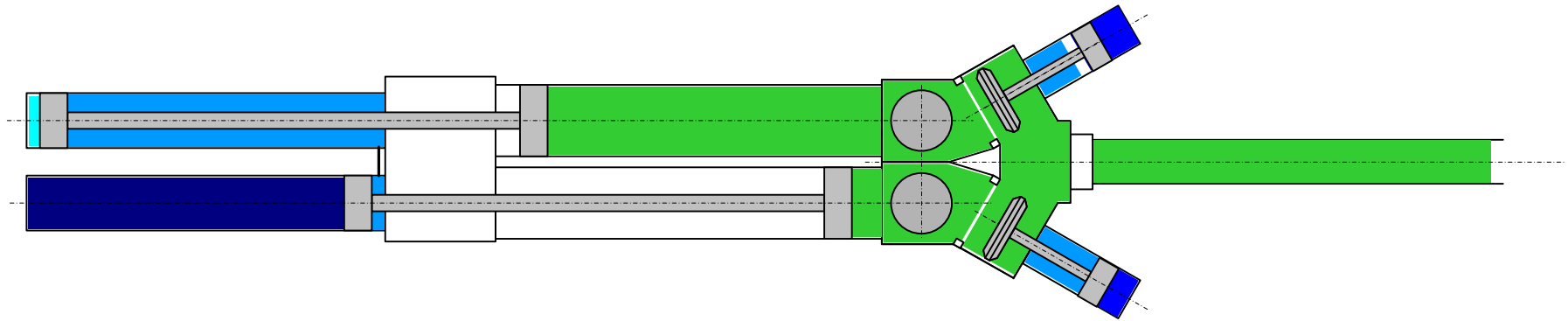
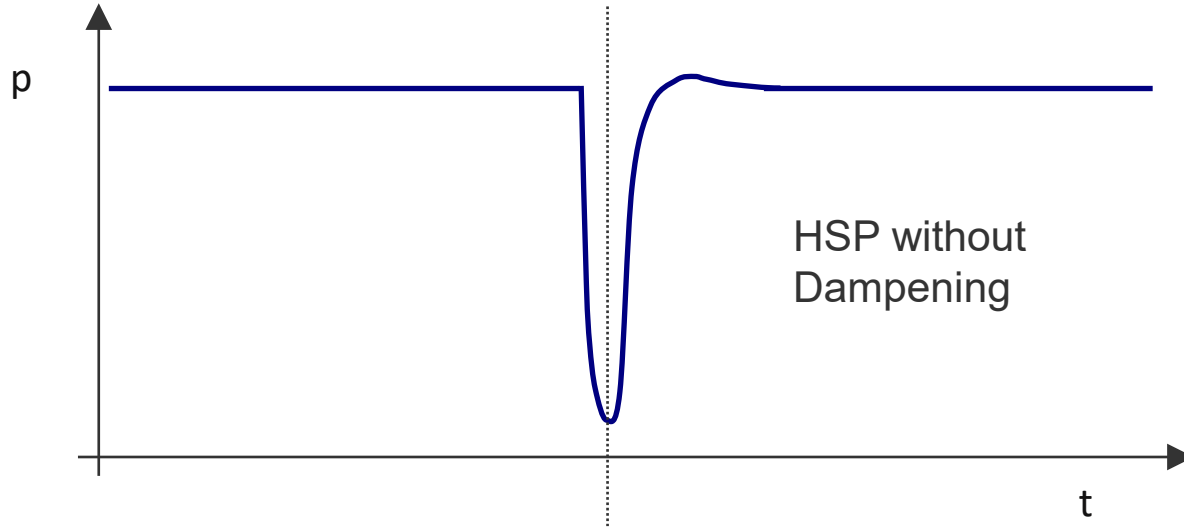

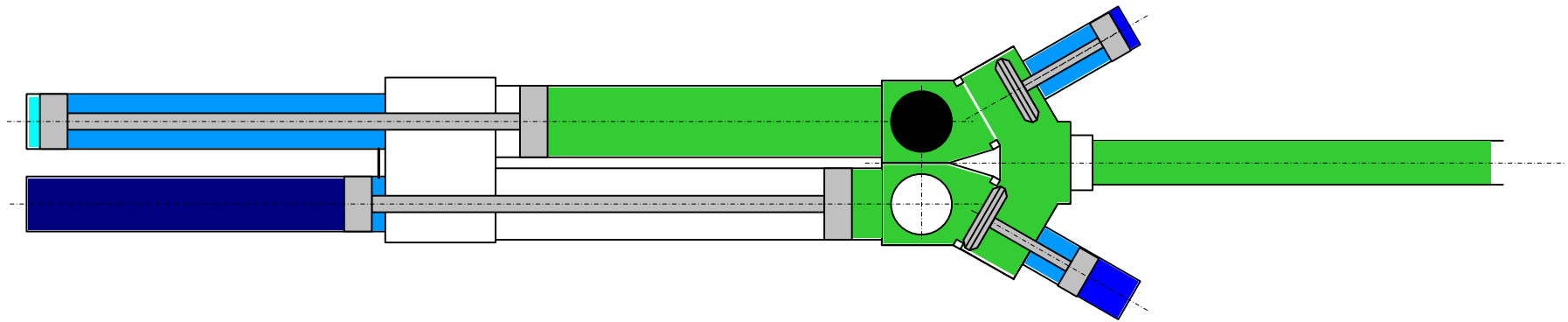
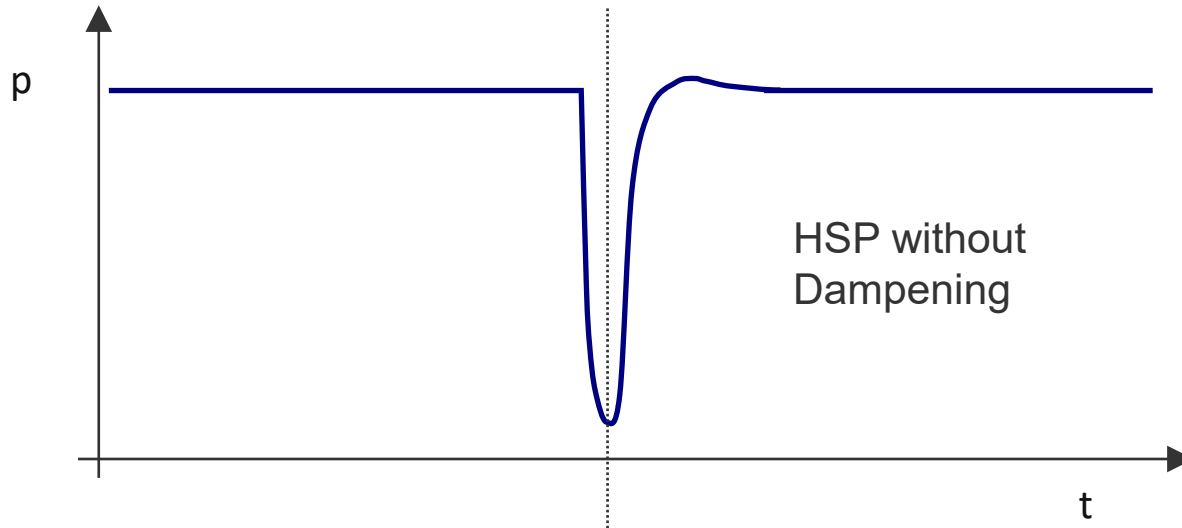

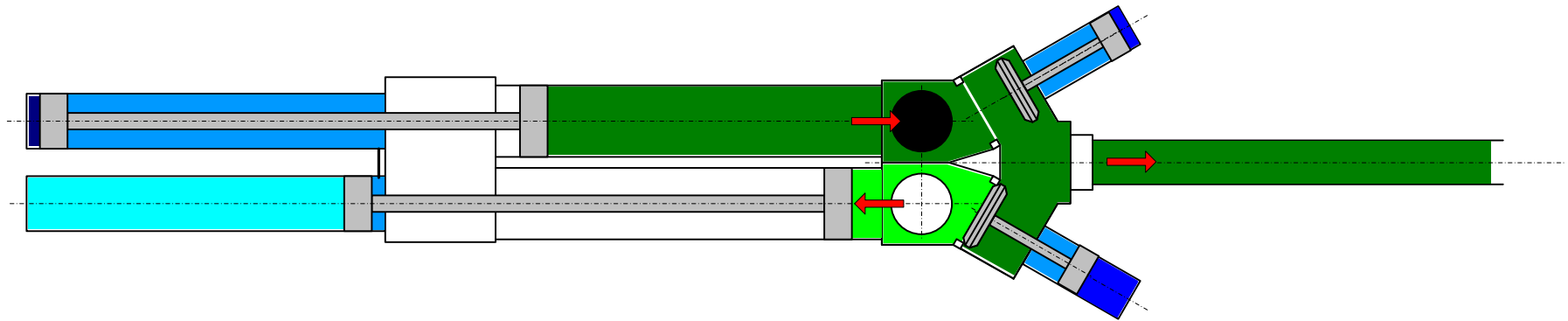
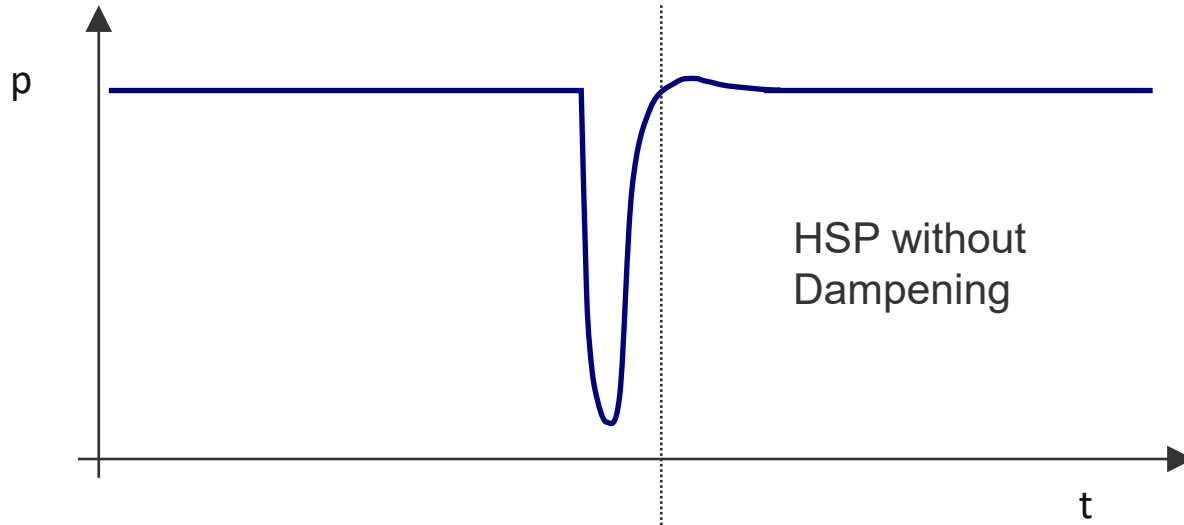

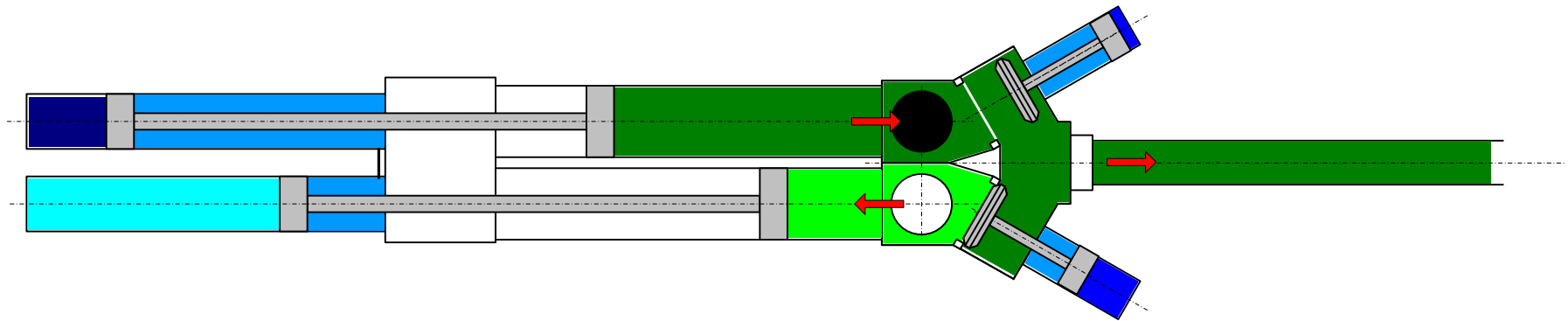
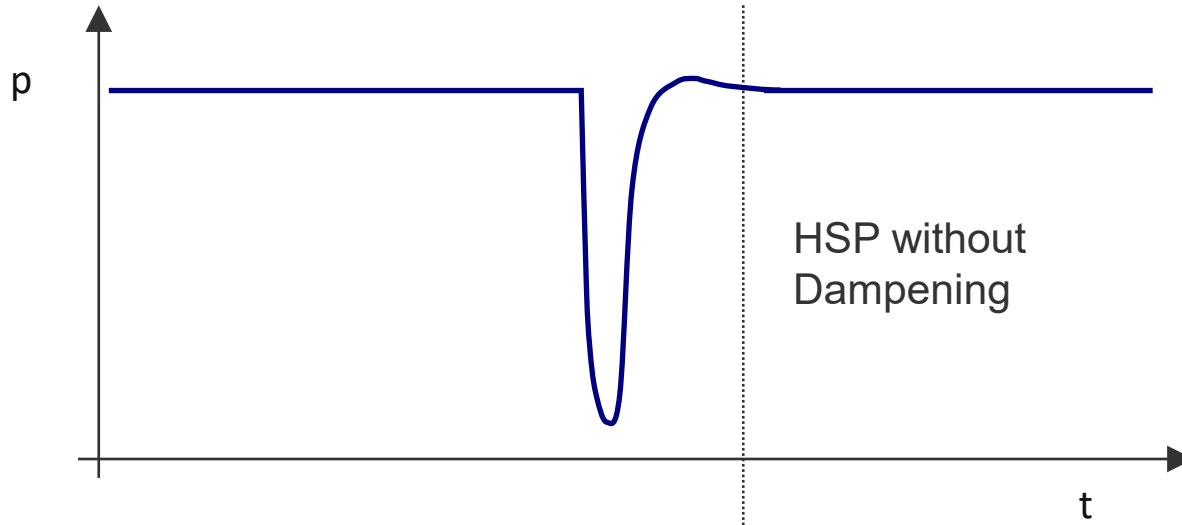

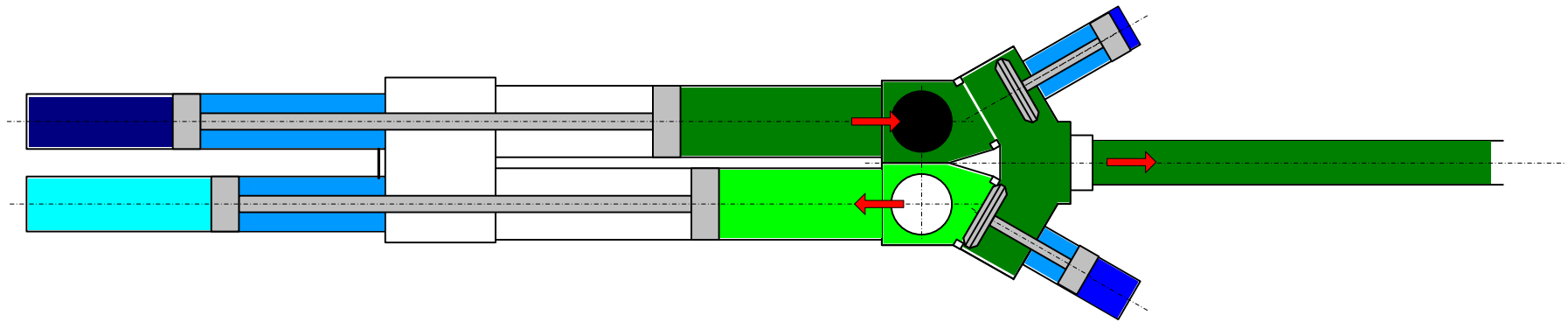
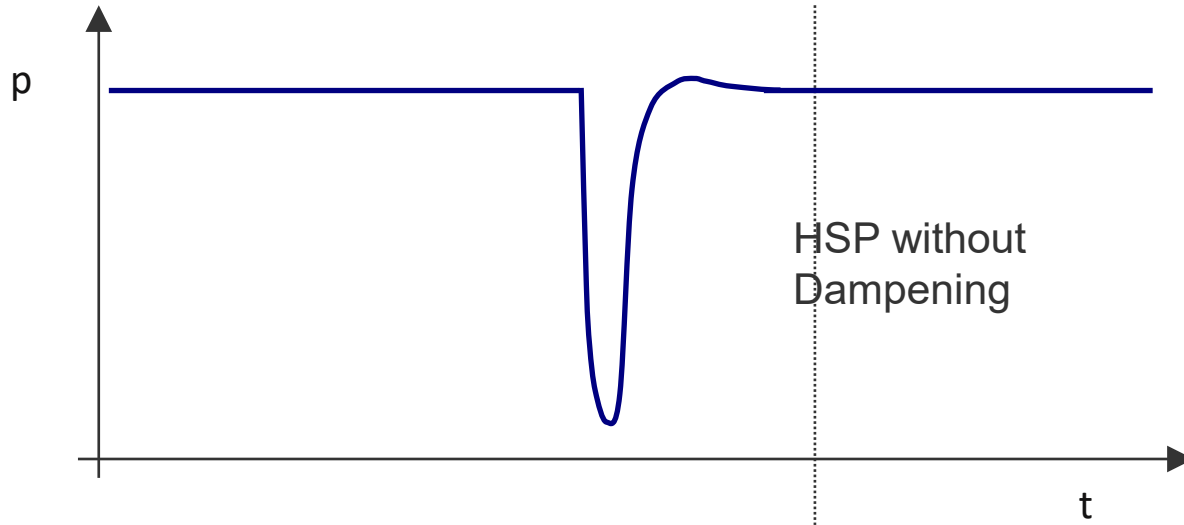

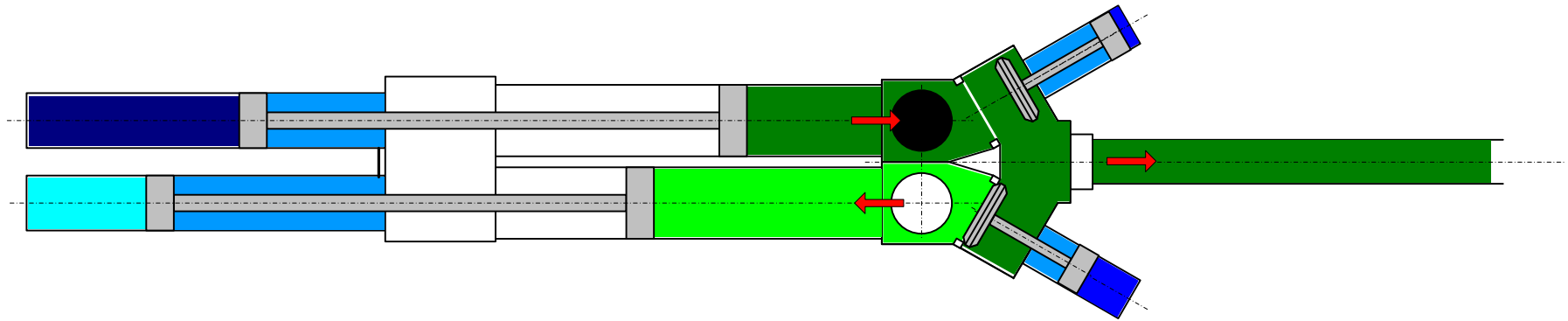
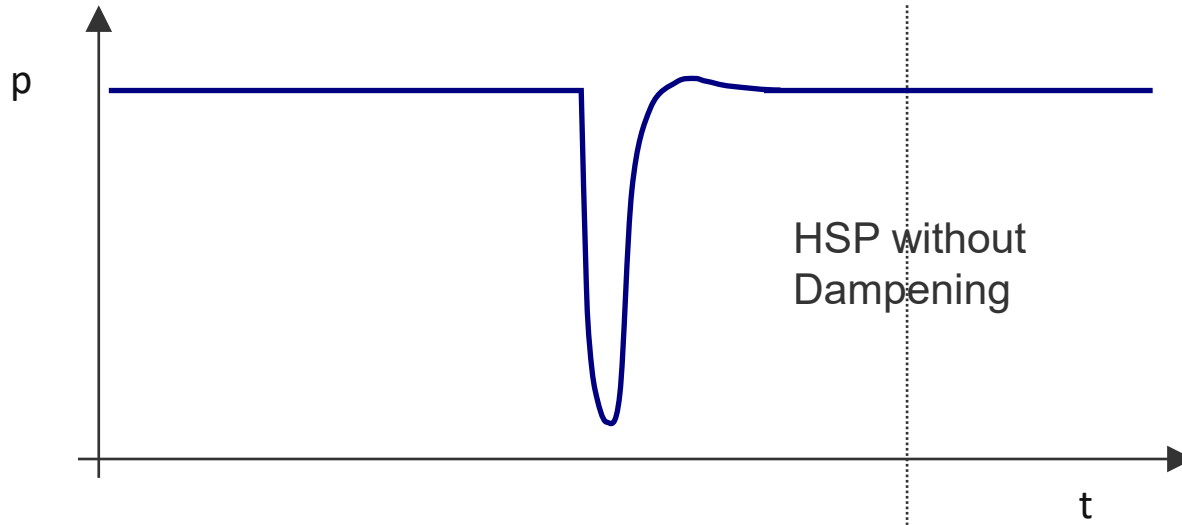

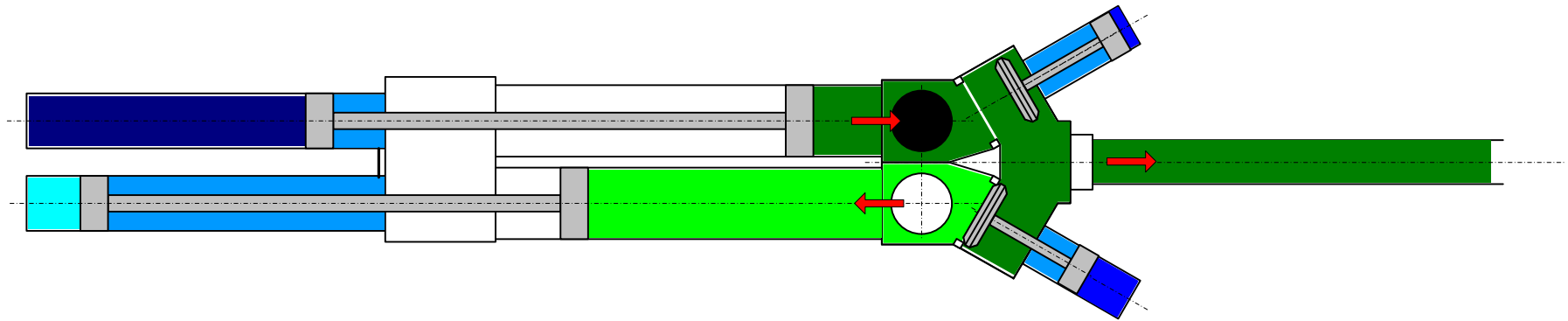
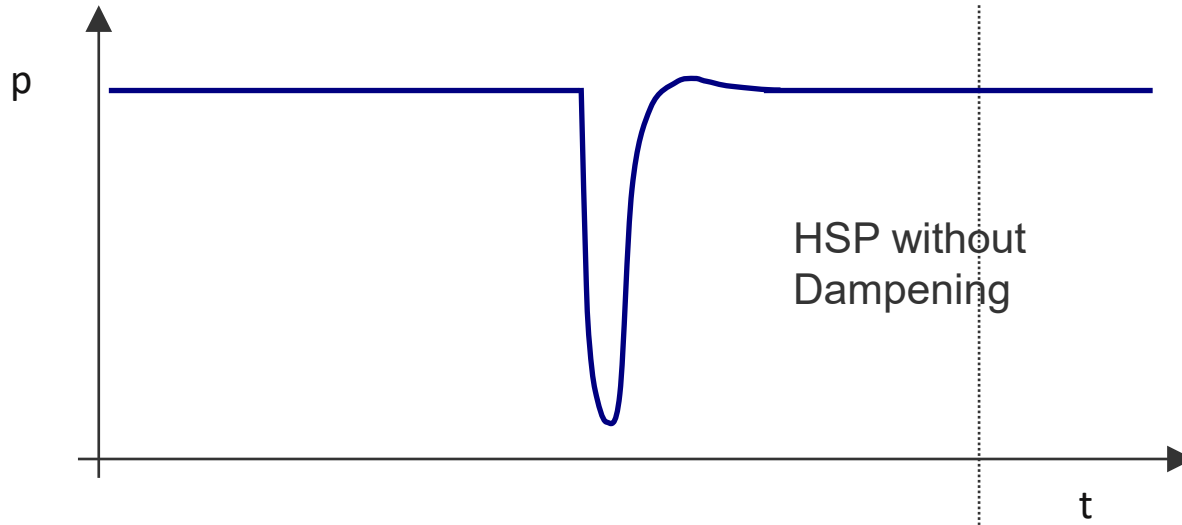

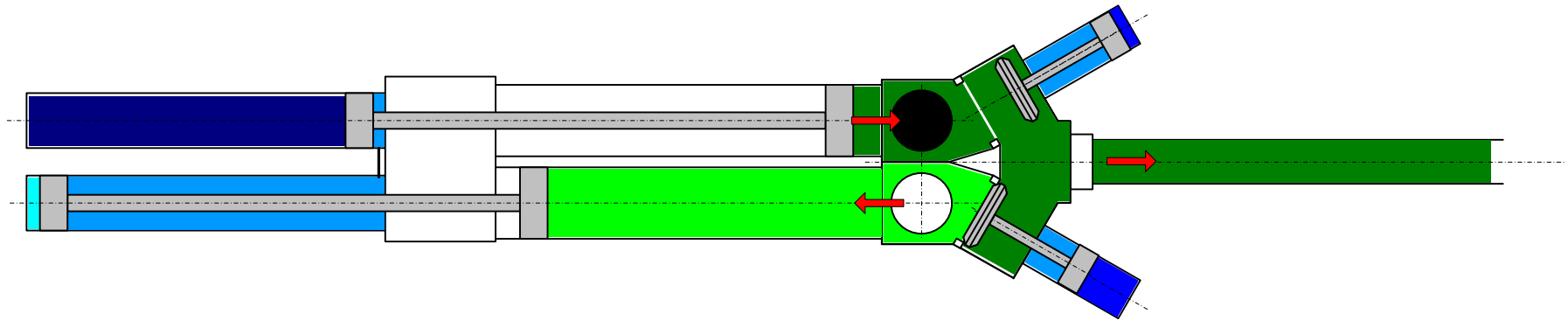
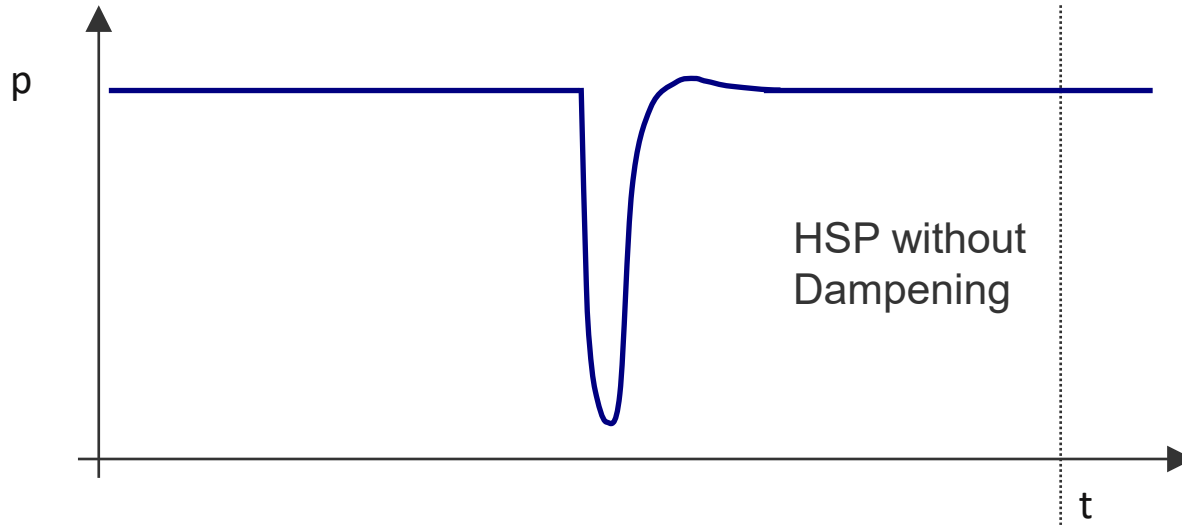

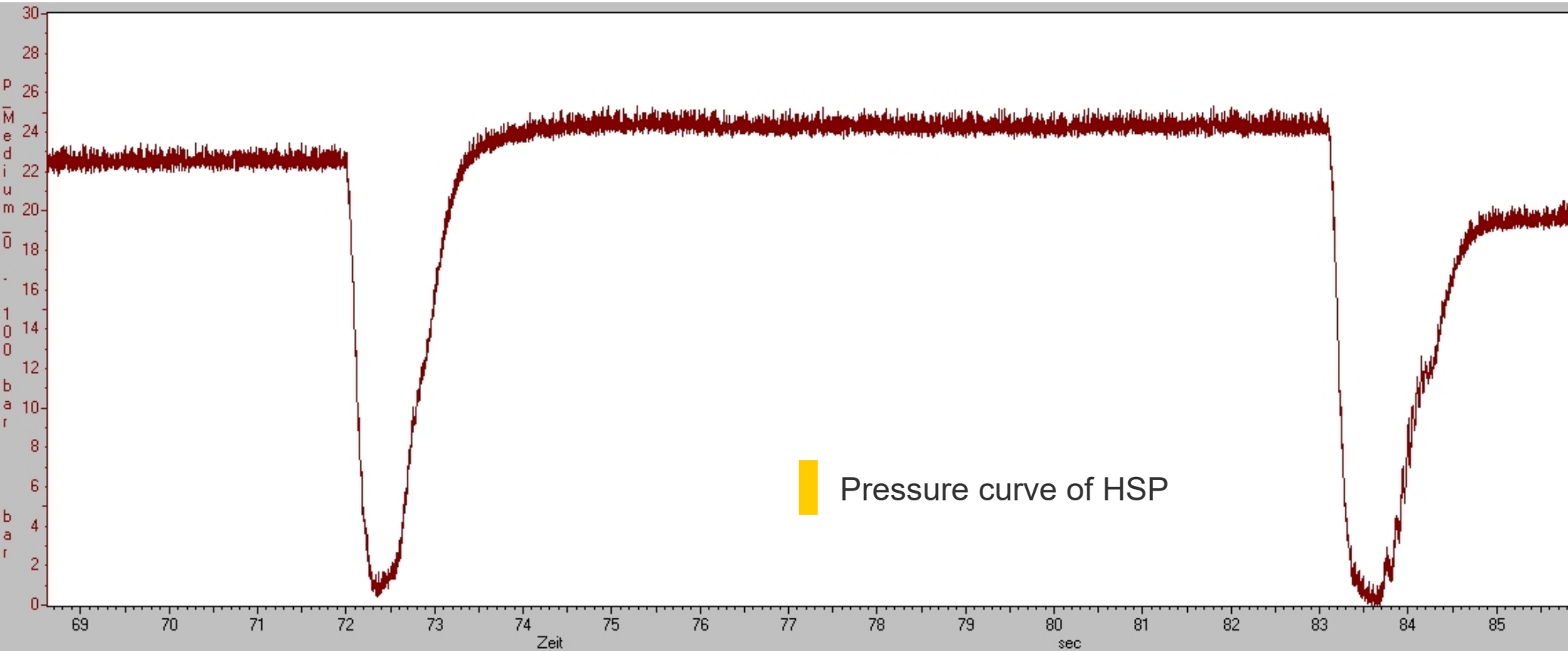

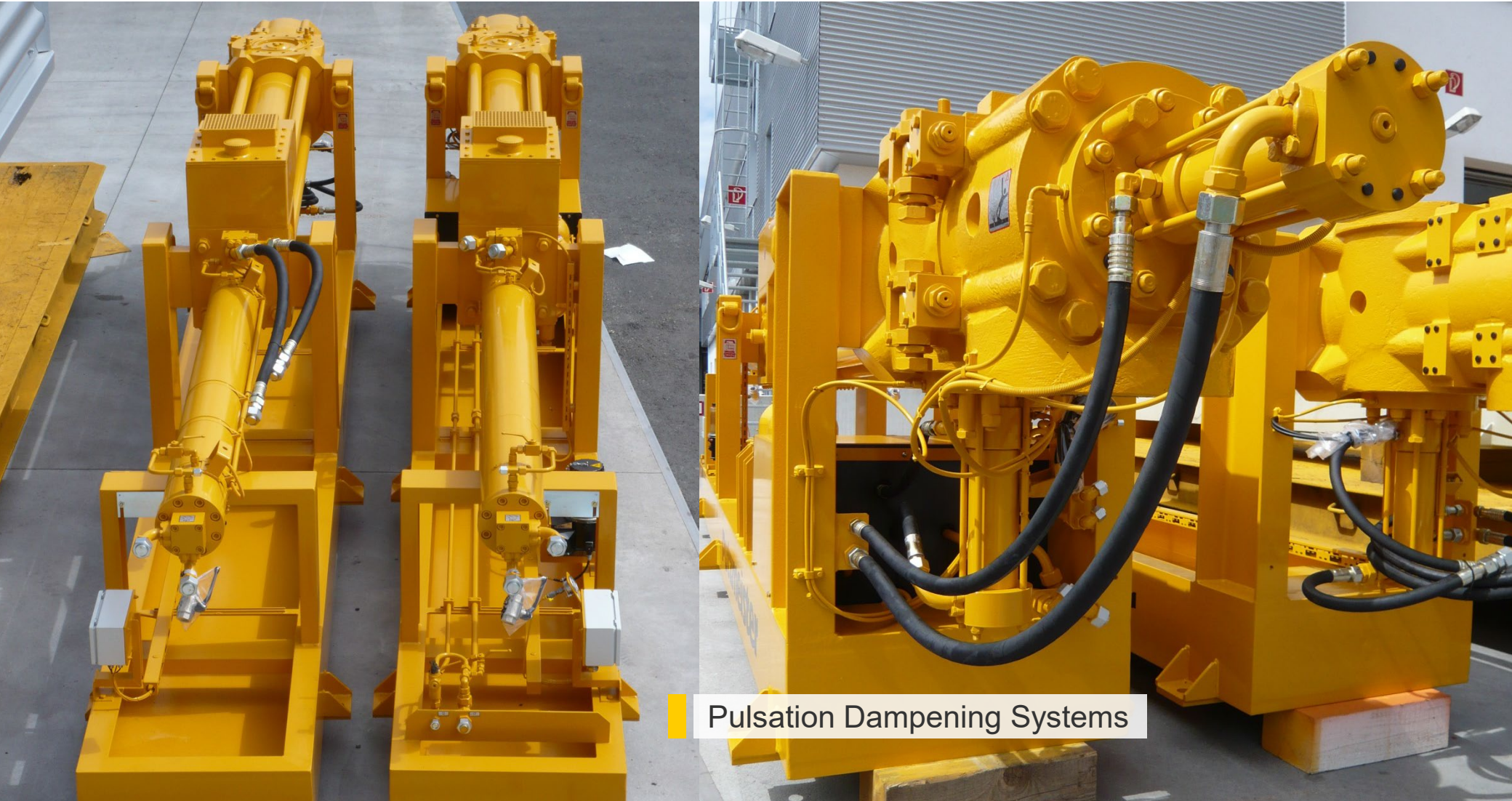

Pulsation Dampening Systems

HSP with **PCF** Putzmeister Constant Flow



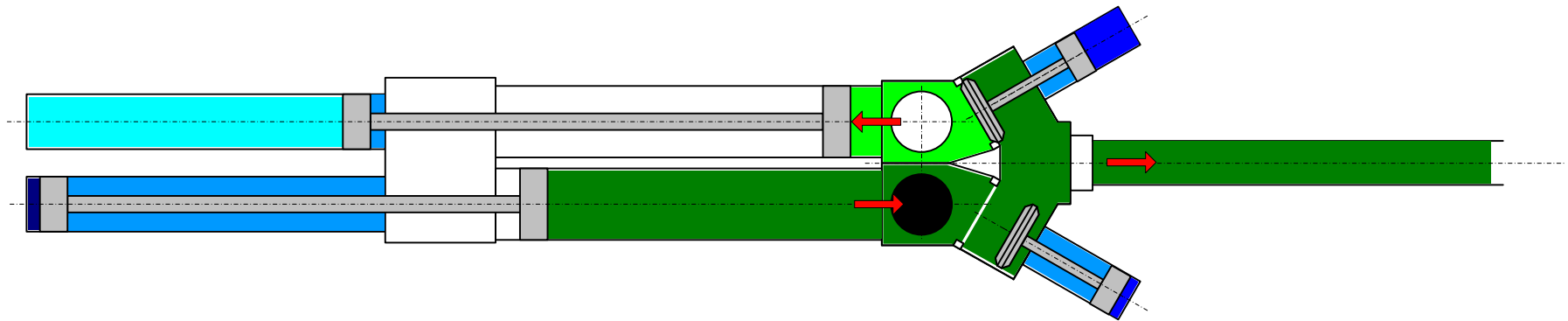
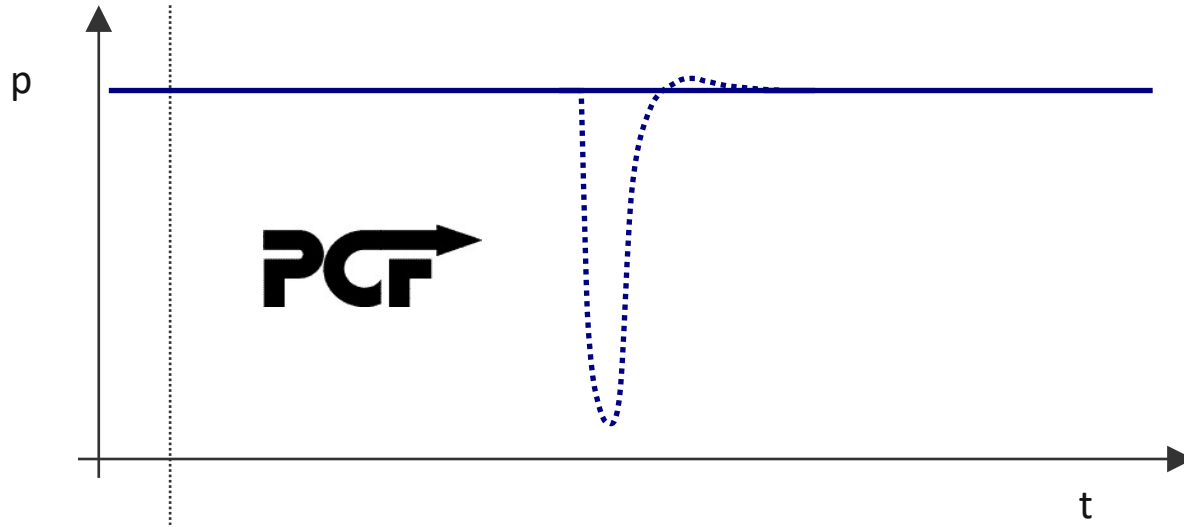

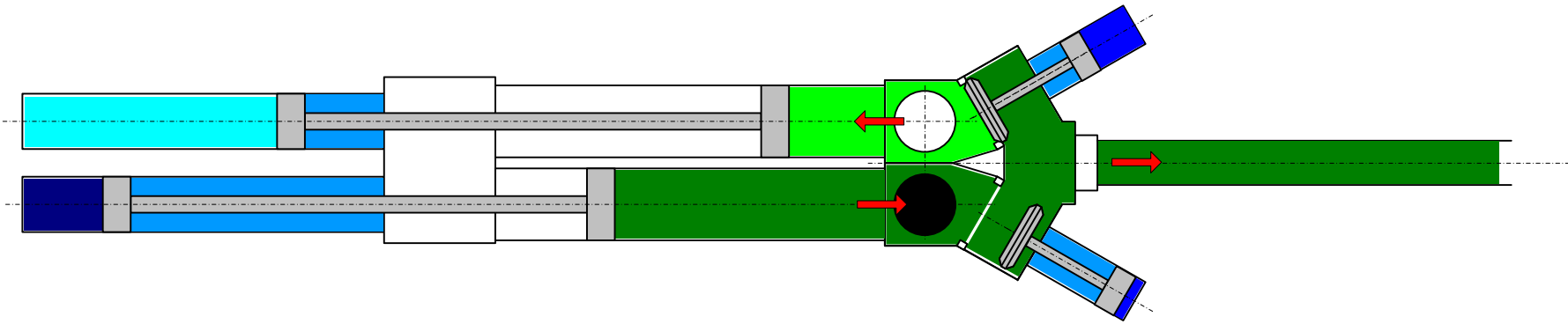
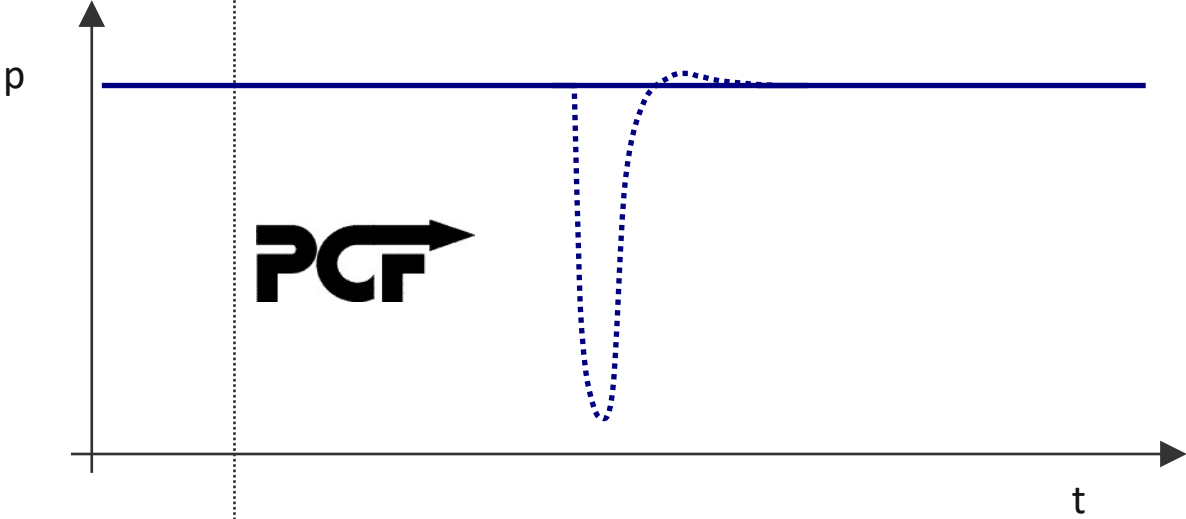

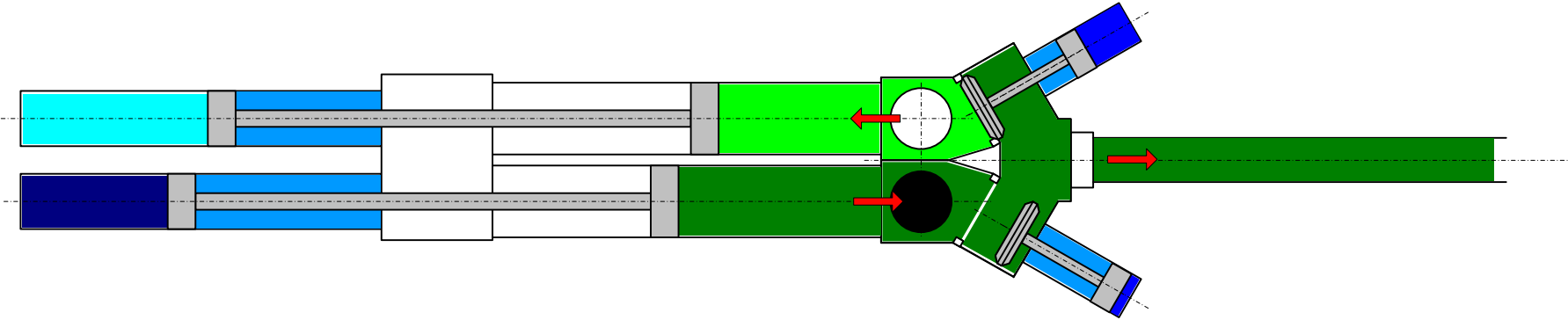
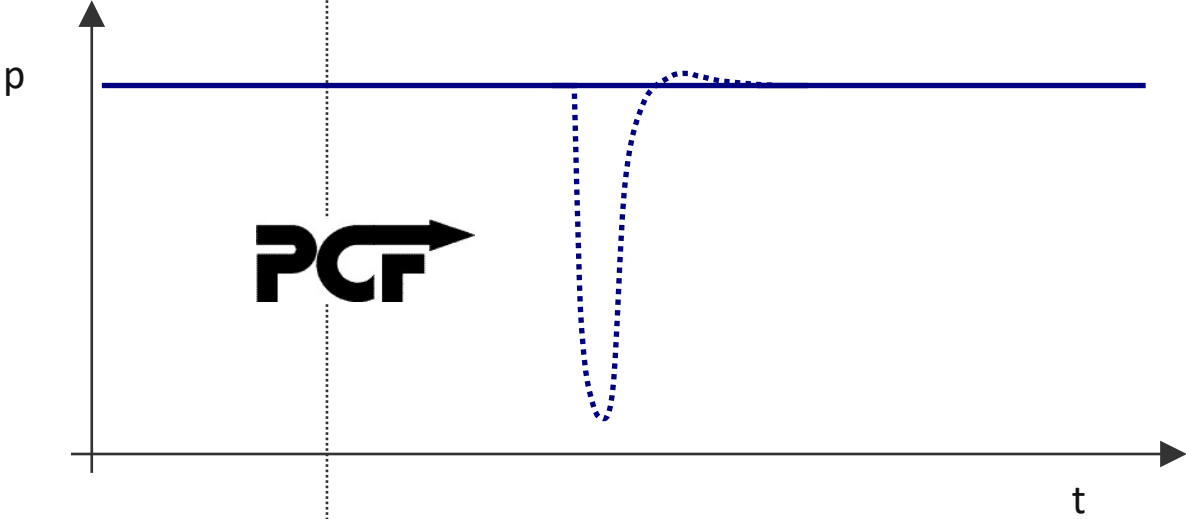

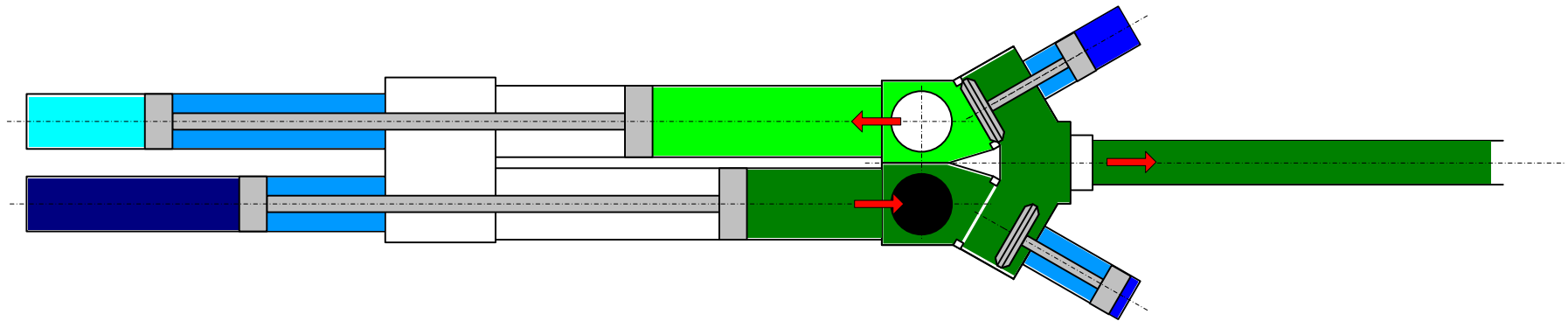
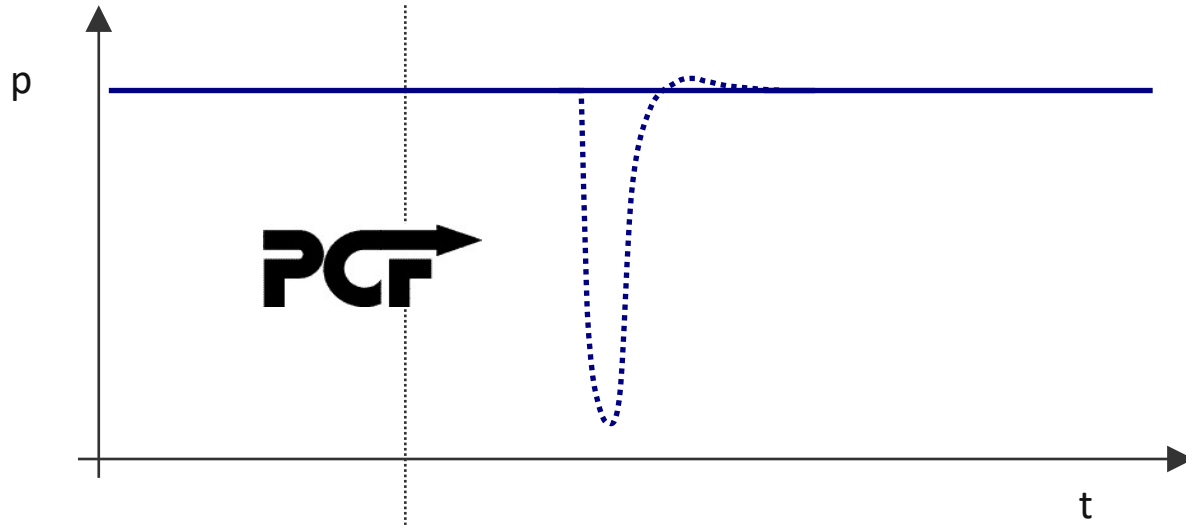

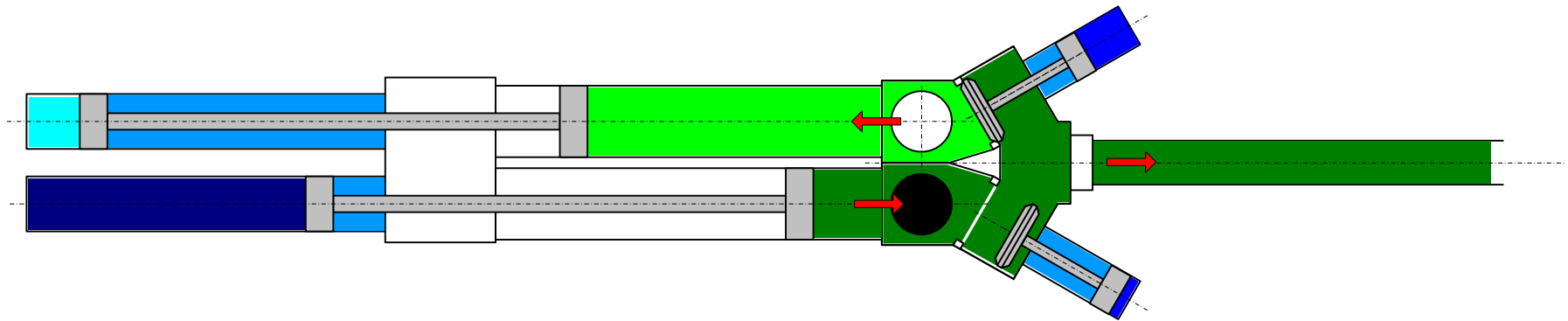
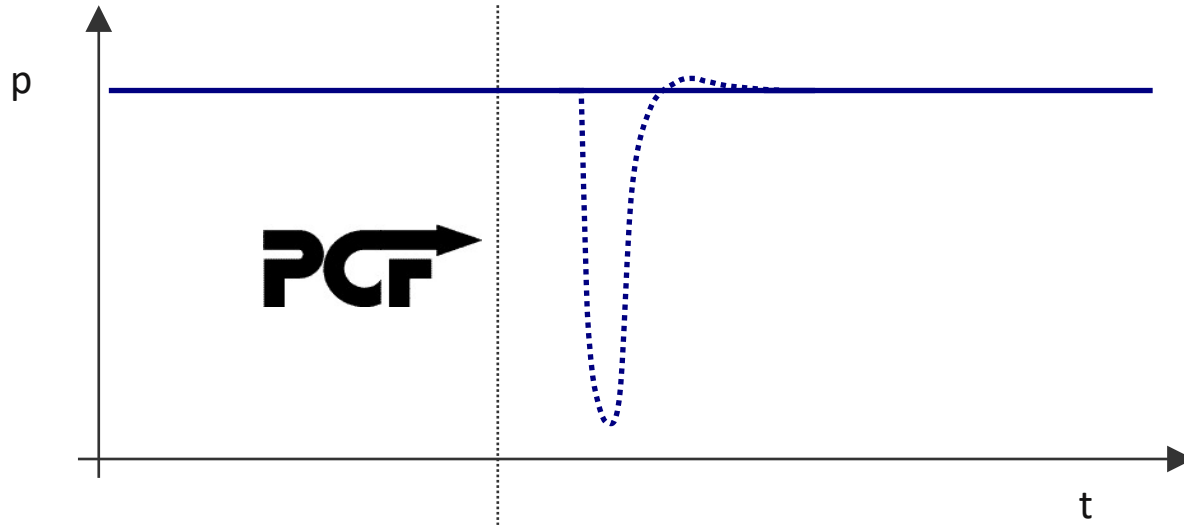

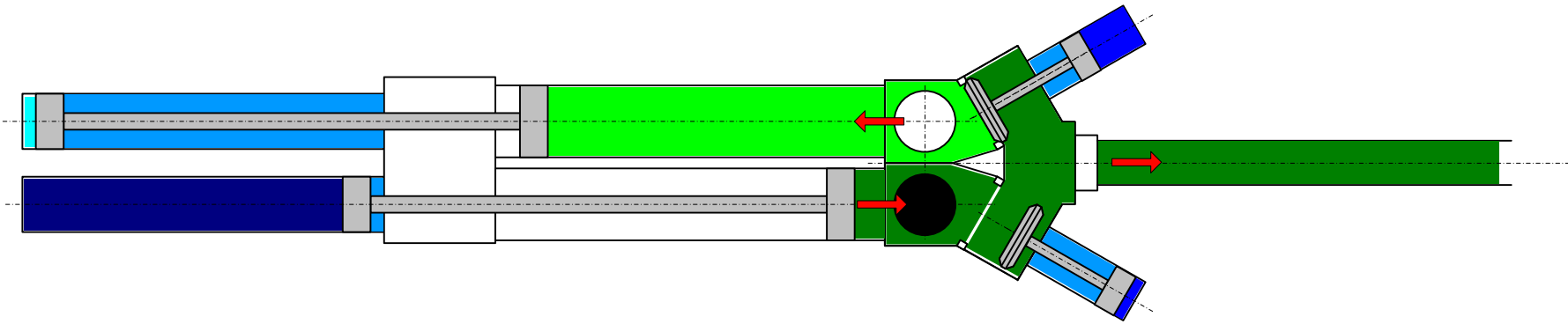
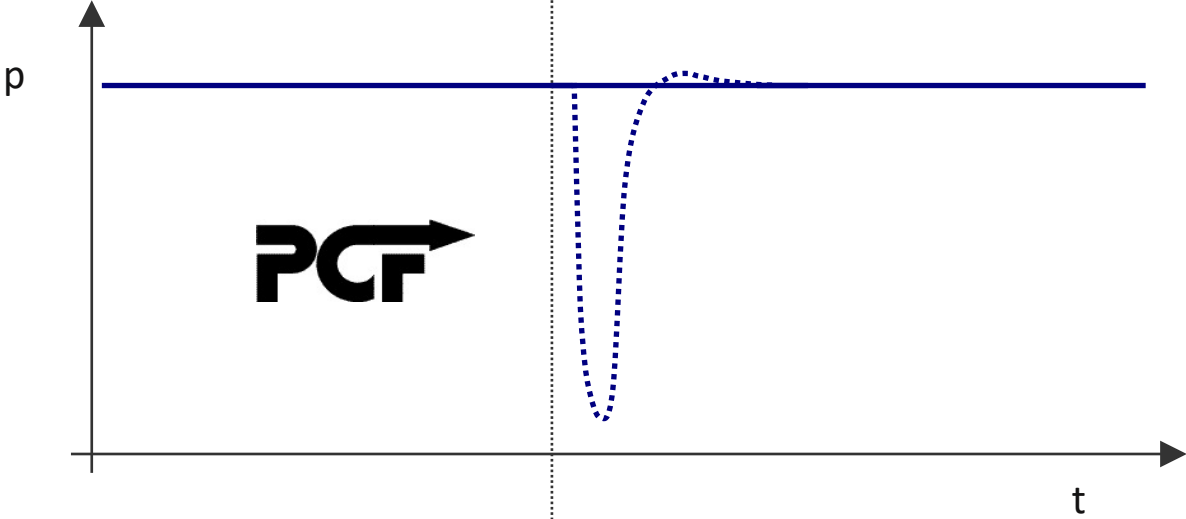

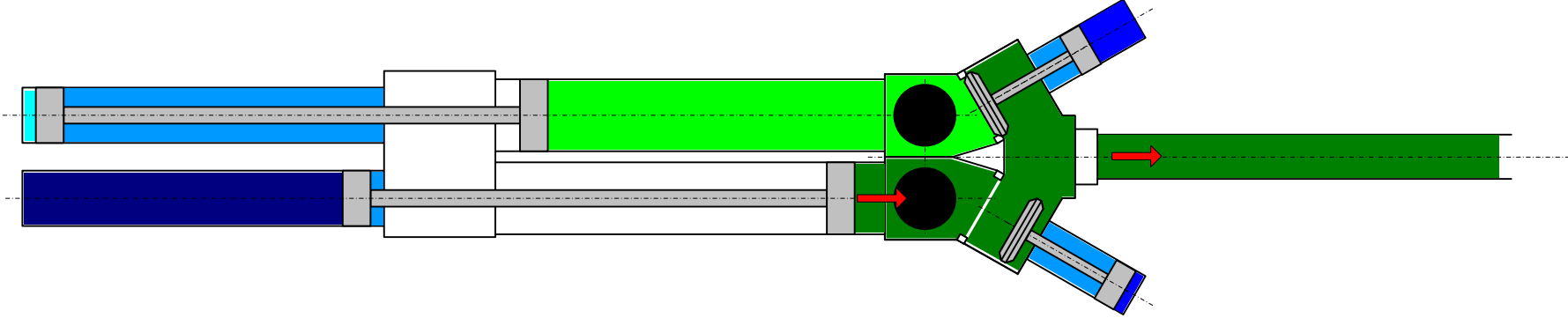
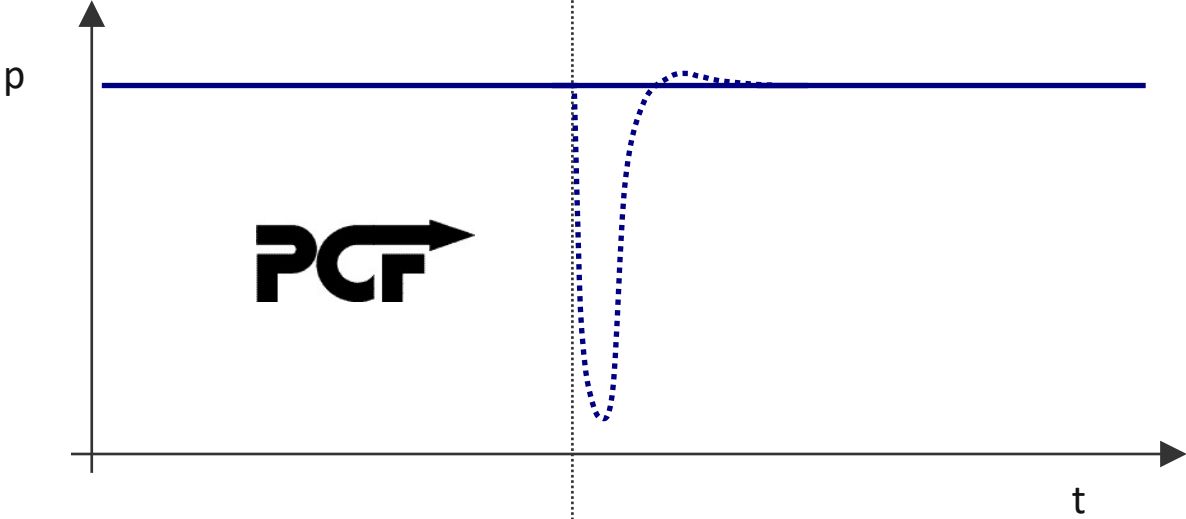

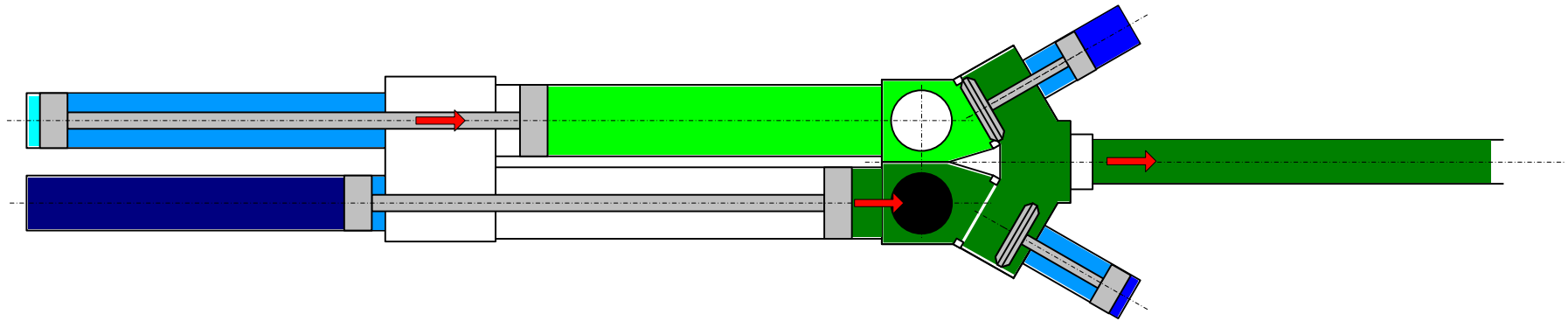
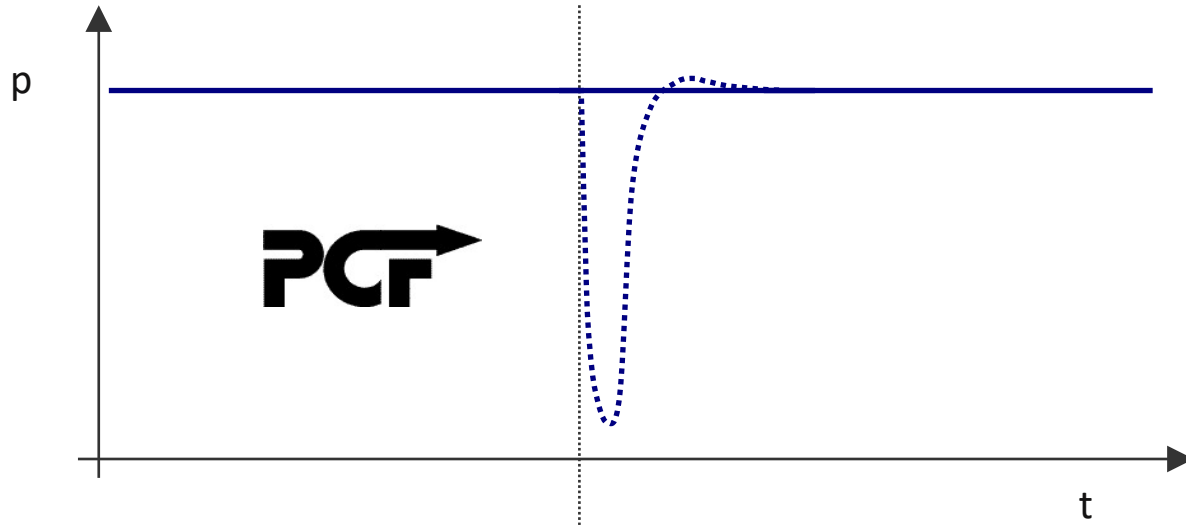

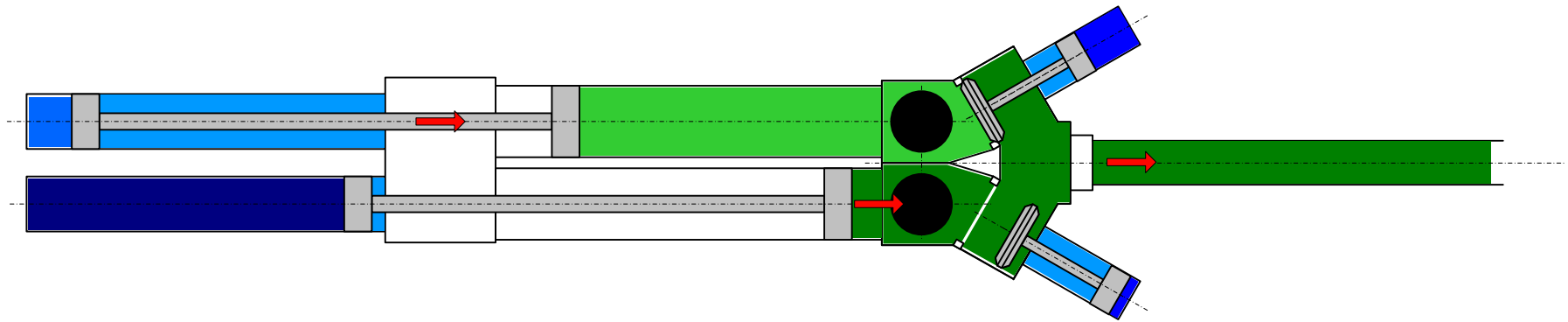
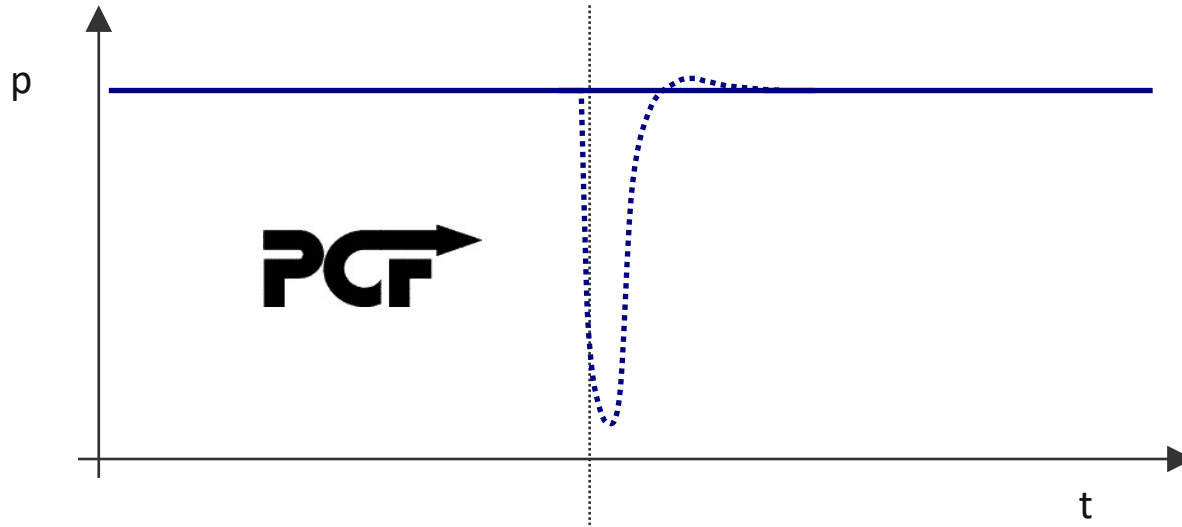

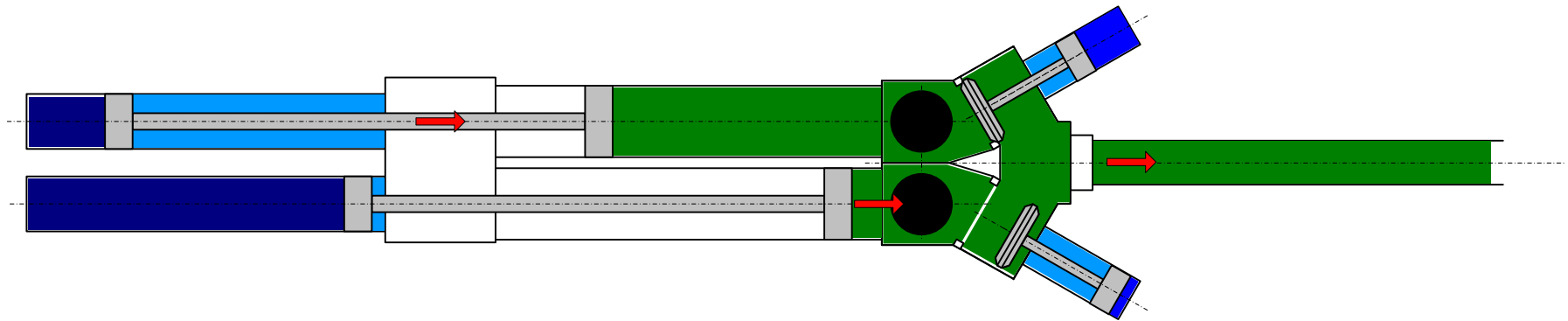
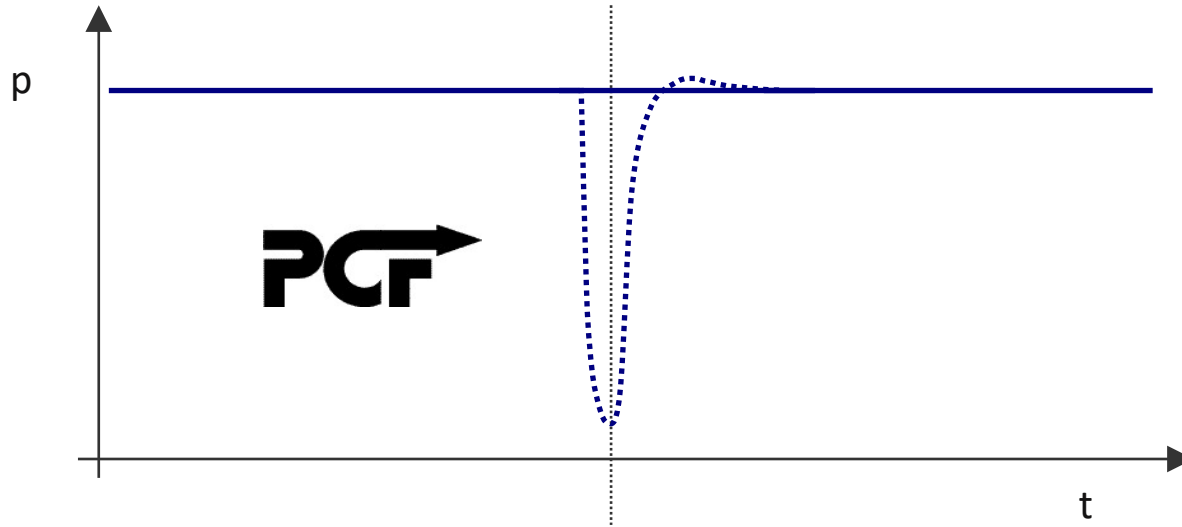

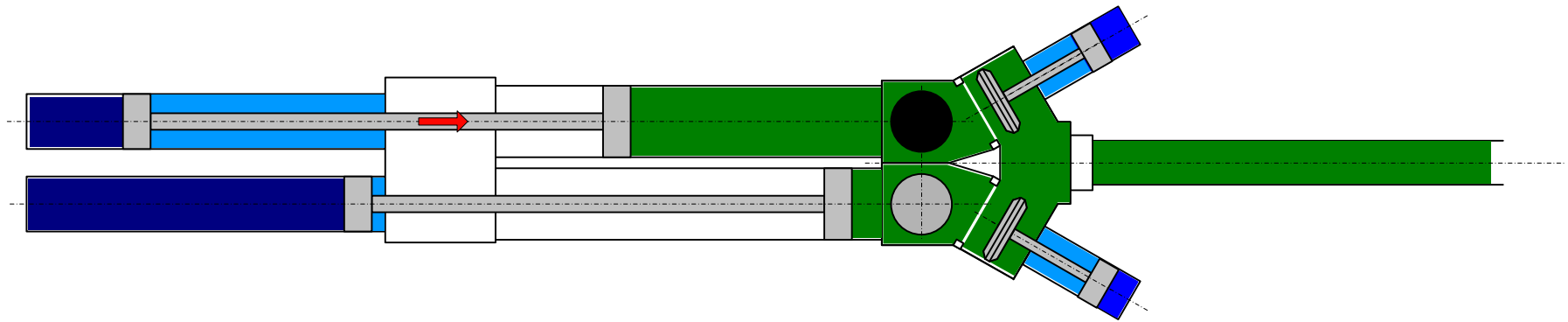
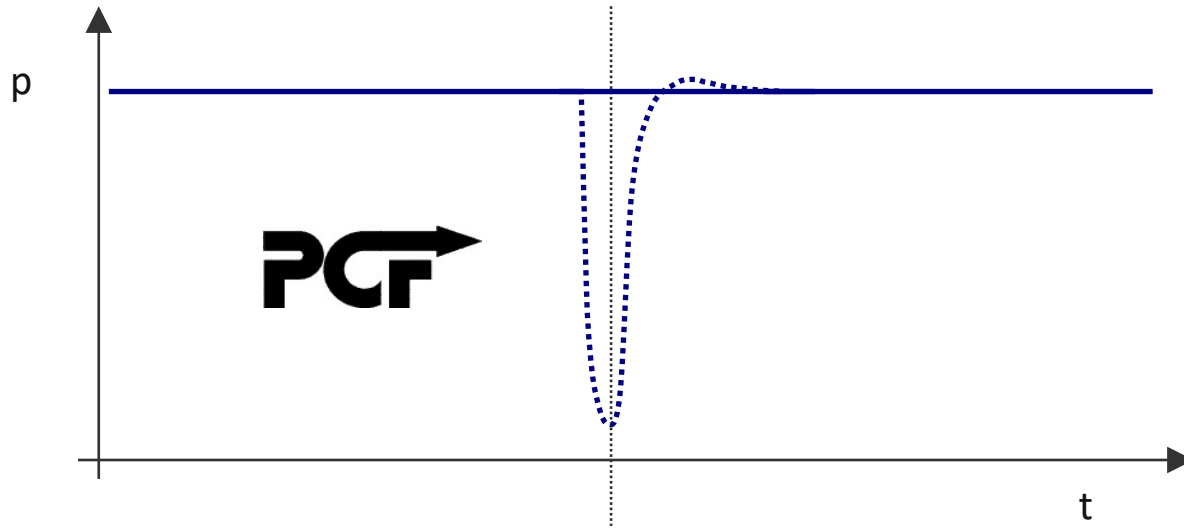

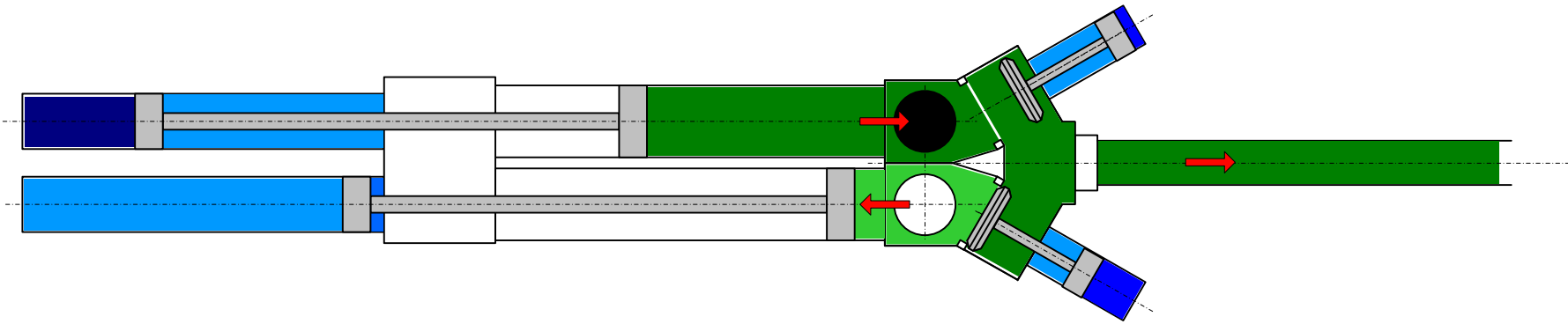
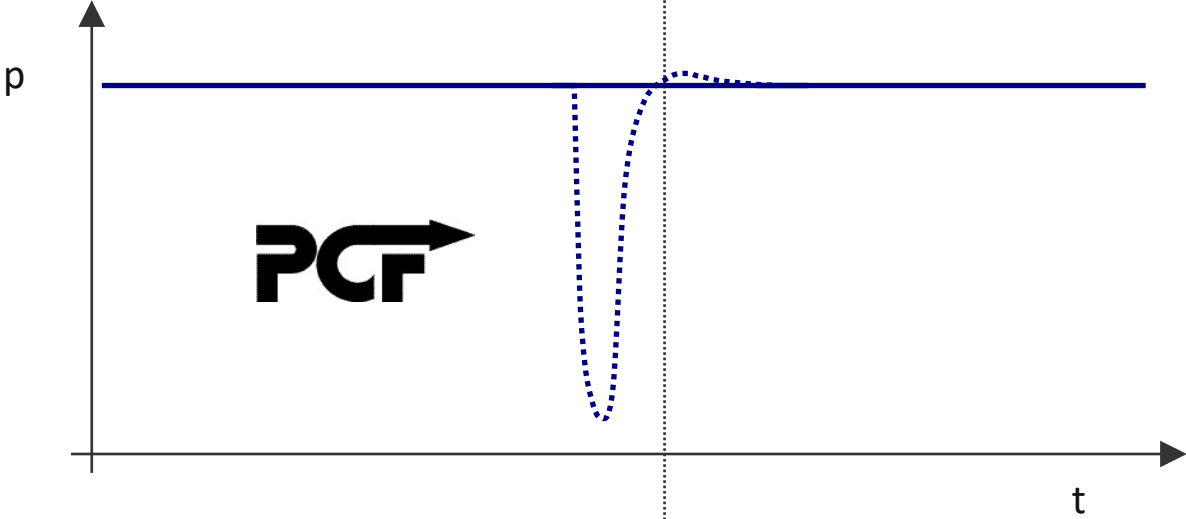

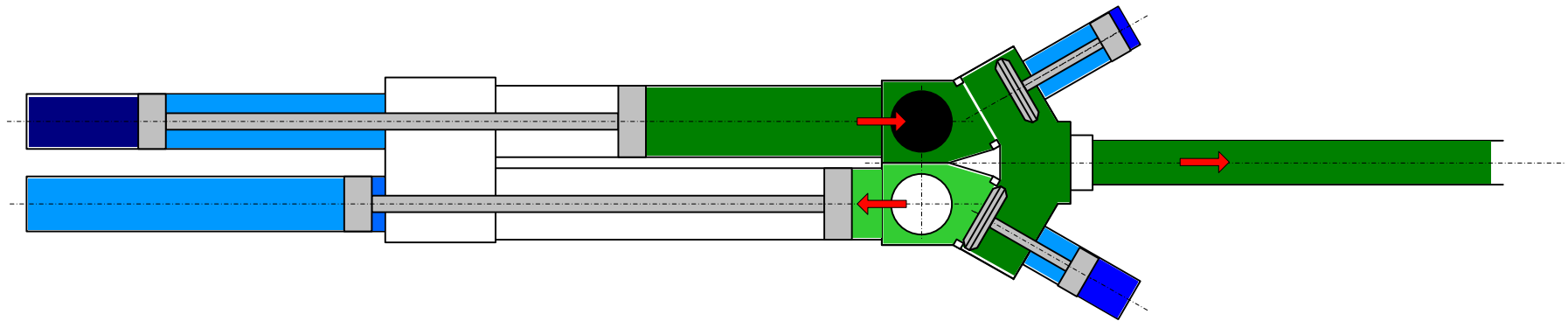
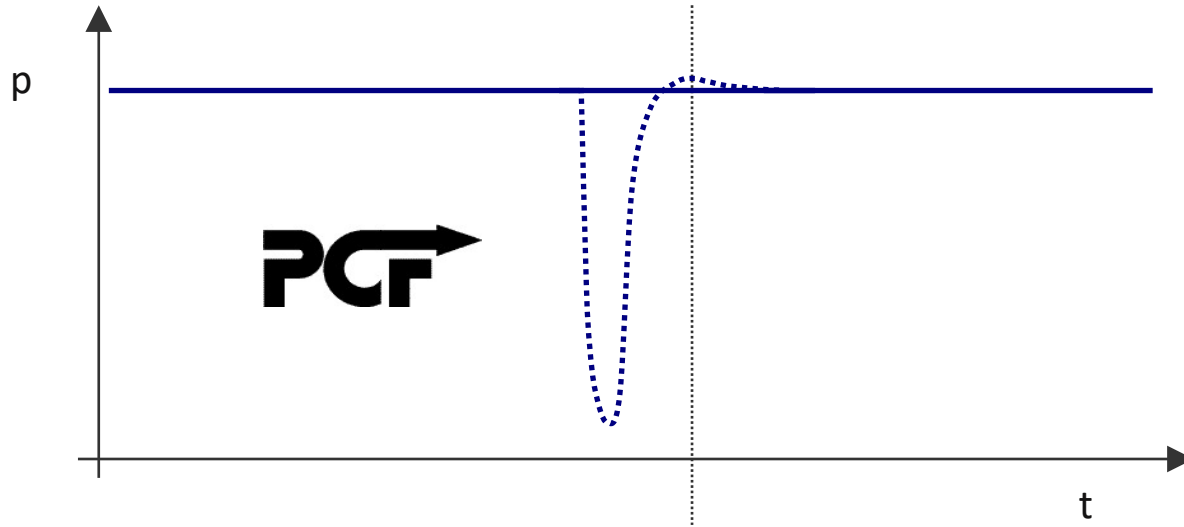

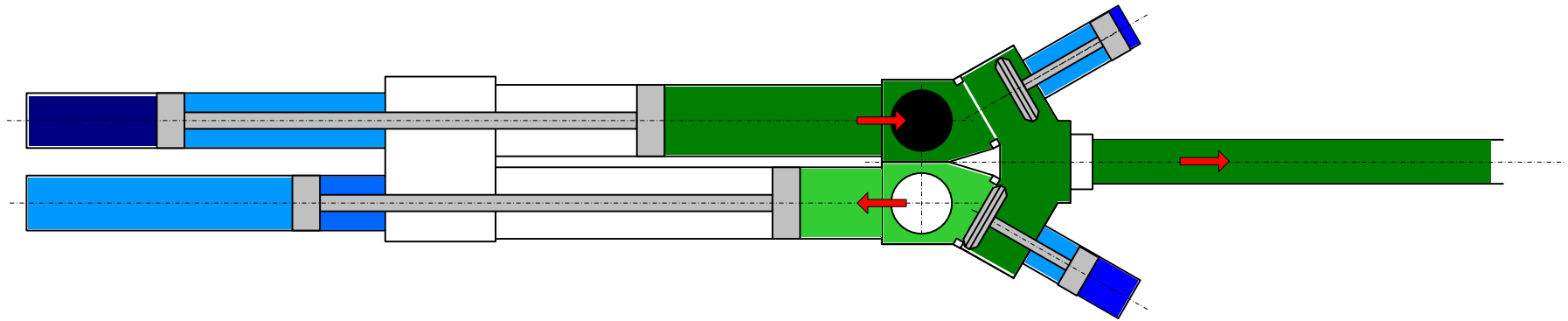
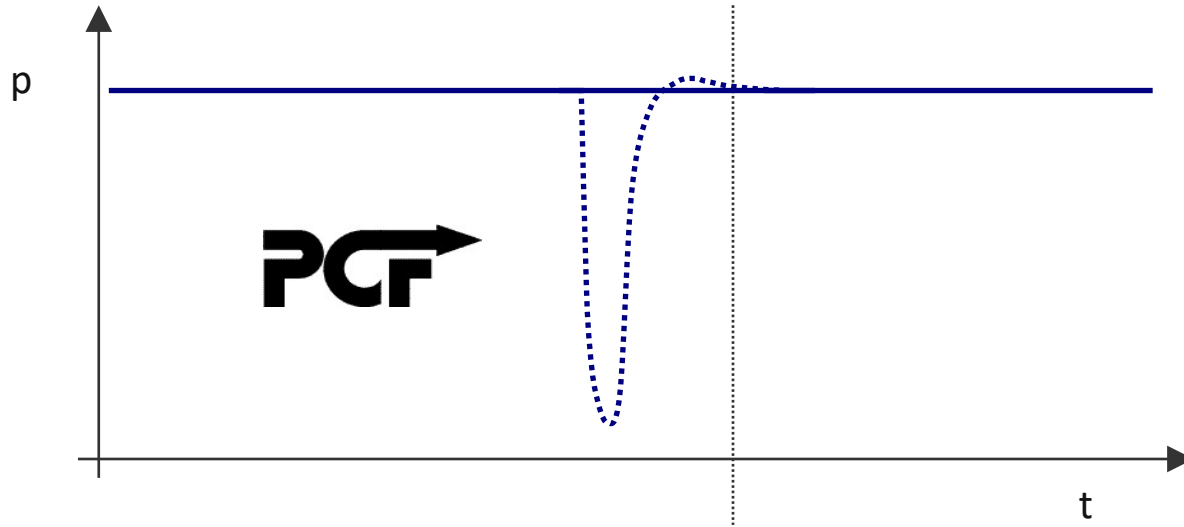

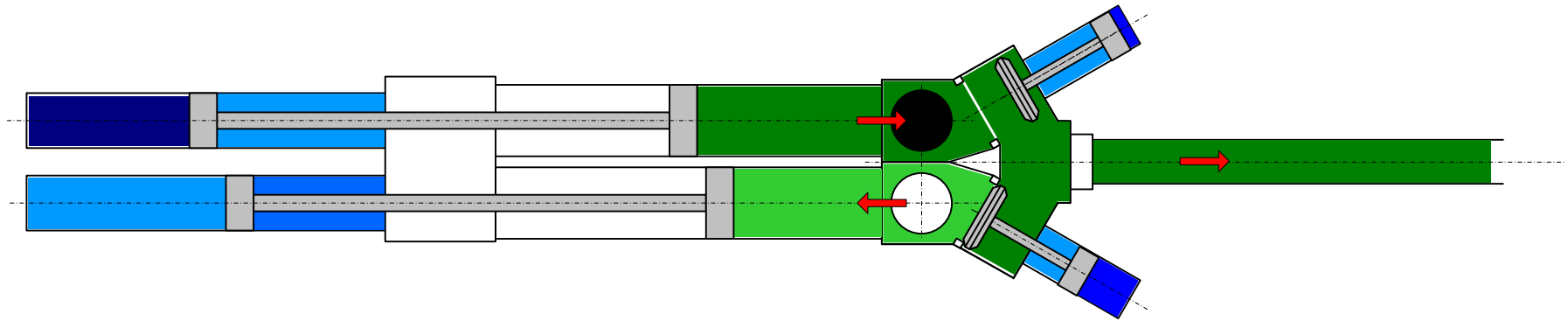
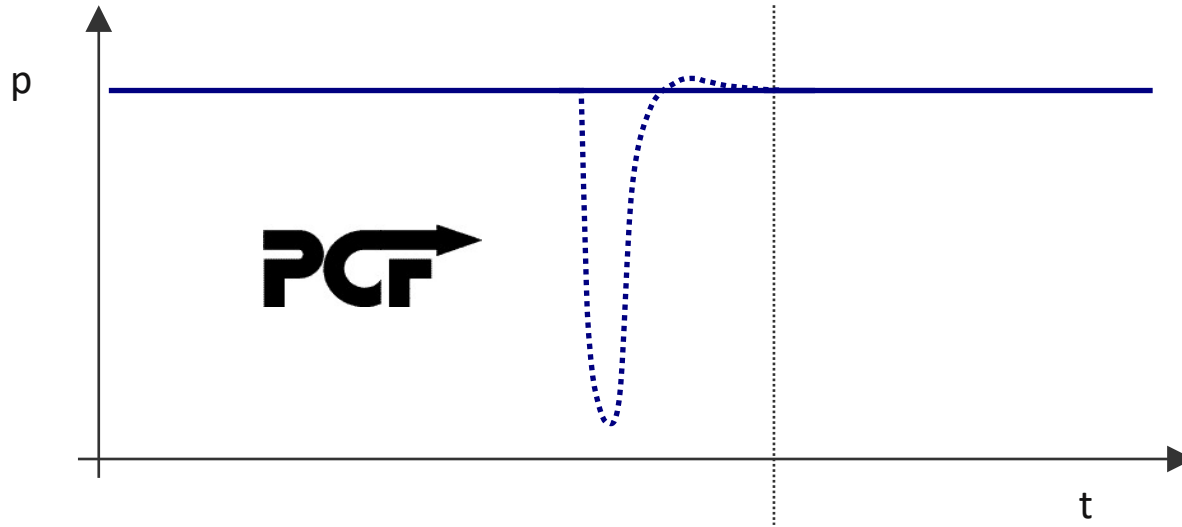

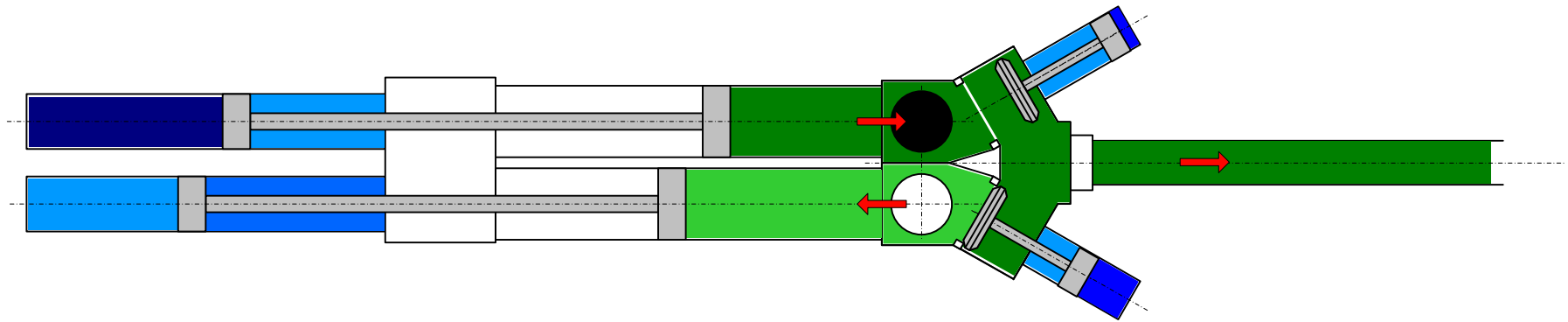
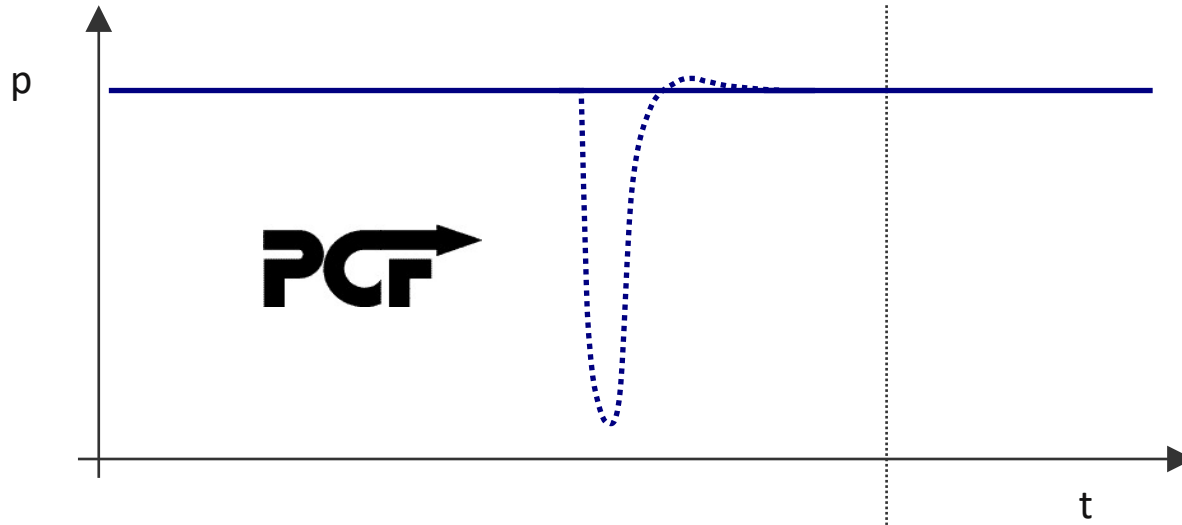

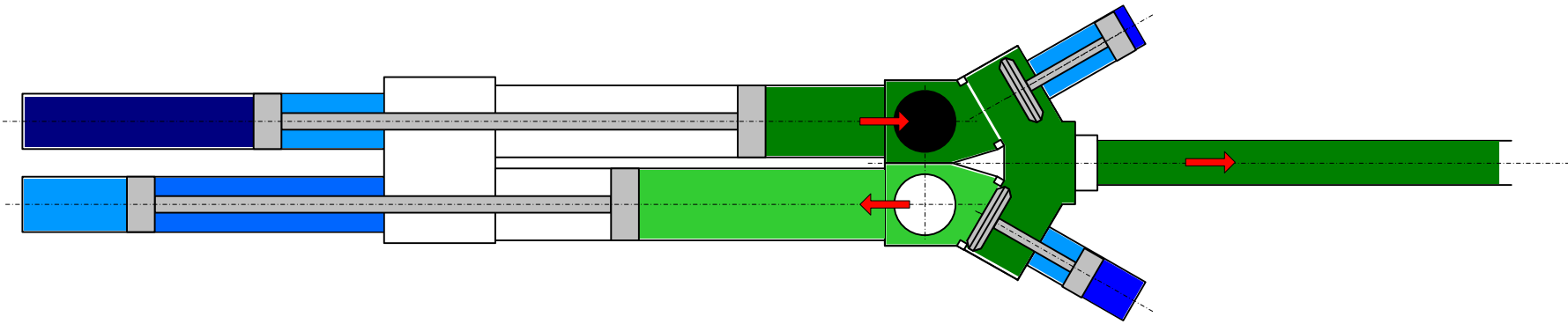
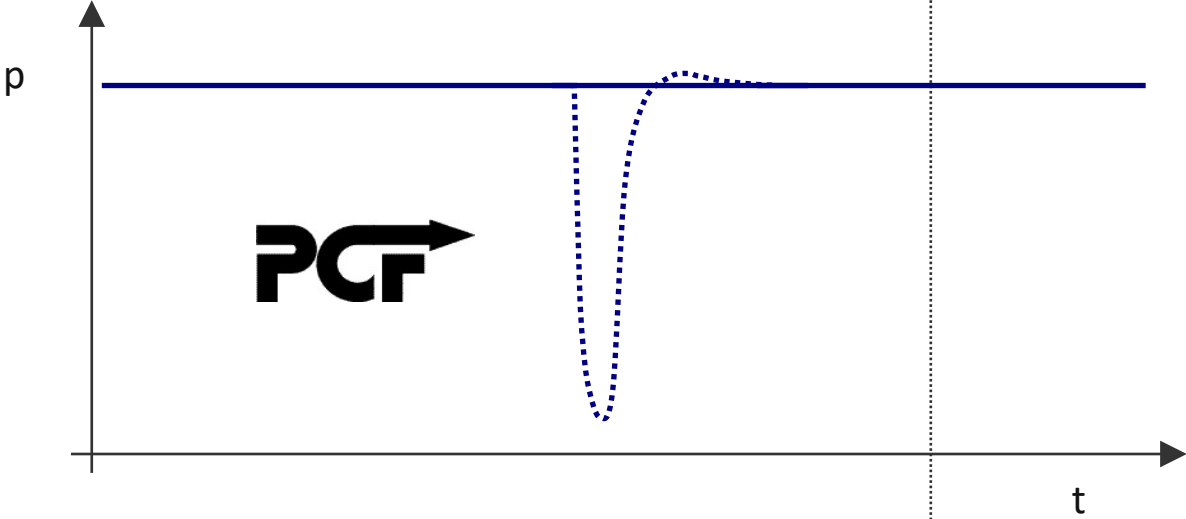

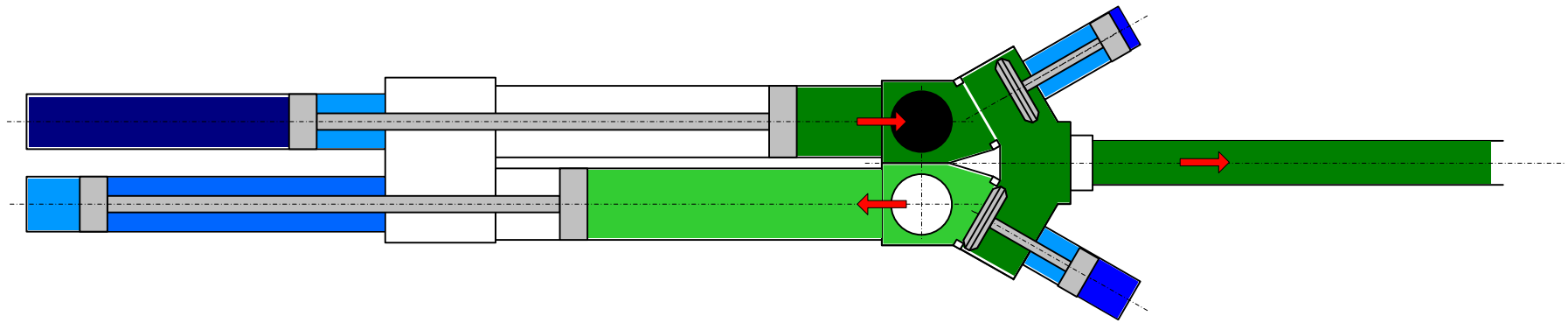
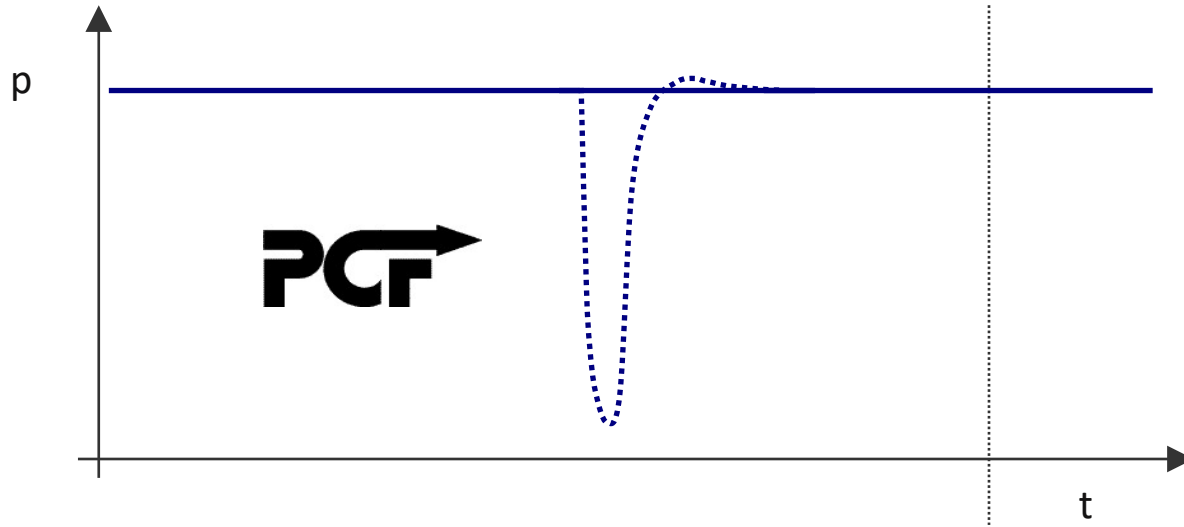

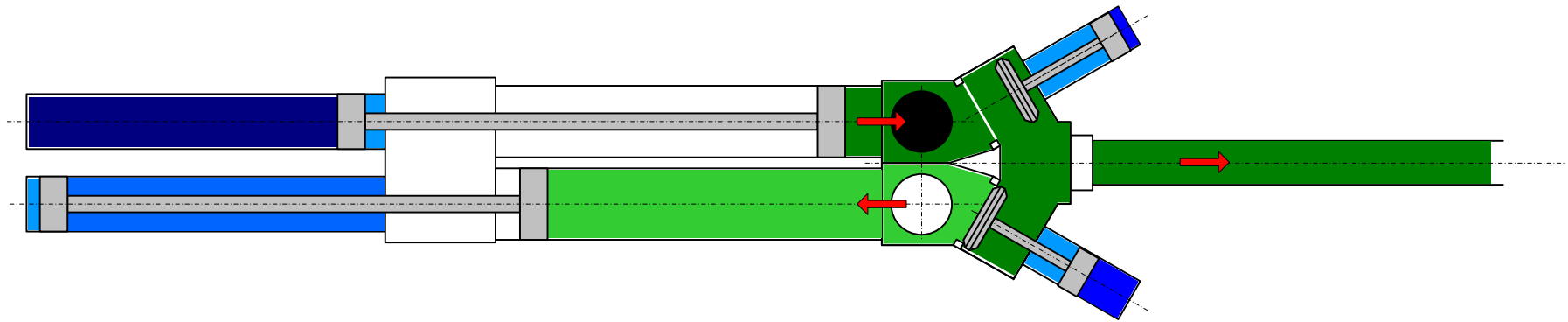
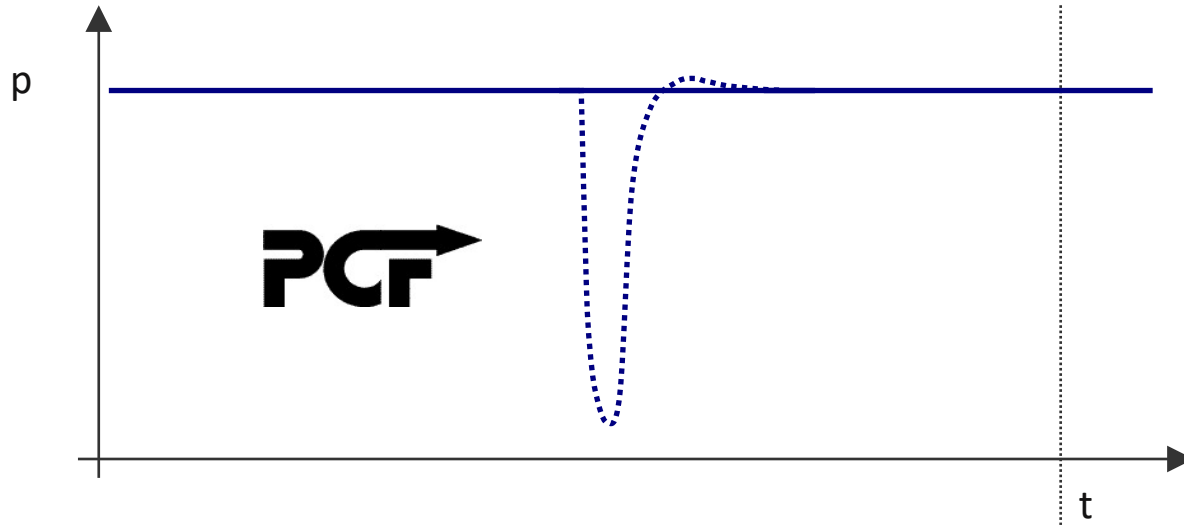

Real Pulsation Dampening pressure curve

PORGERA

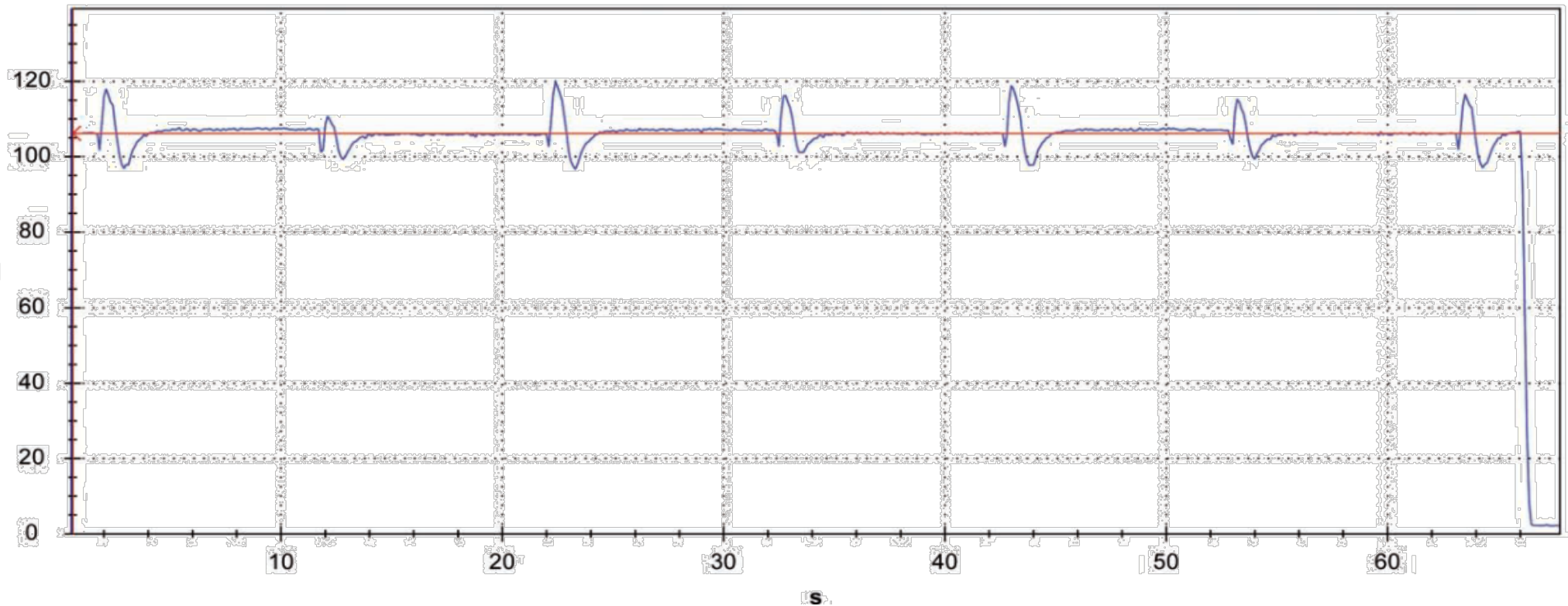

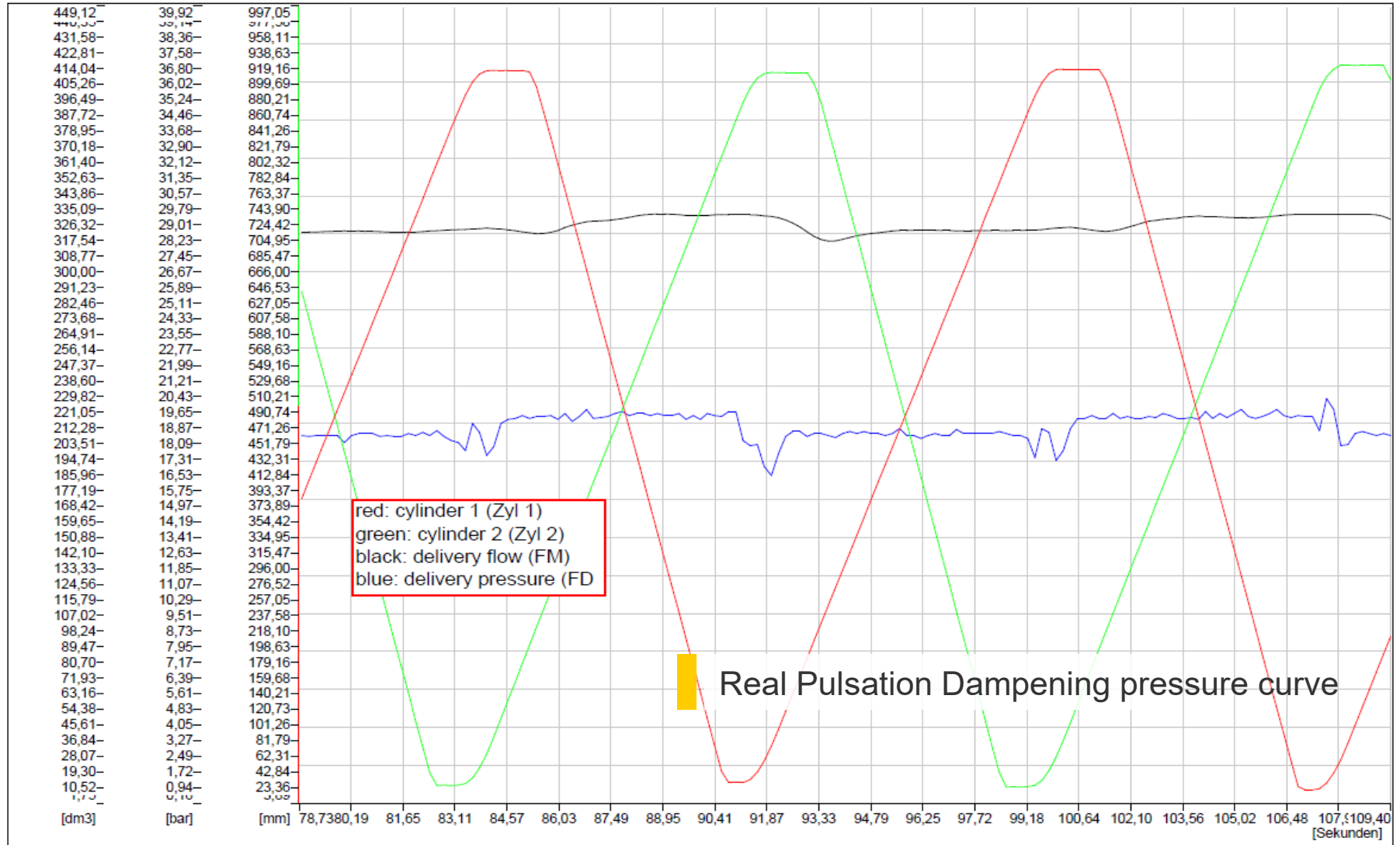



Advantages of Putzmeister Constant Flow (PCF)

- Best Possible Dampening Device for Seat valve Pumps
- PCF is working in different pressure levels without any adjustment
- PCF has no membrane or other additional mechanical parts with a limited life time
- PCF can be used for different pumping material at the same installation
- Easy cleaning and maintenance of the entire system as no additional mechanical parts have to be installed within the pipeline
- Can be used for hardening material (cemented paste)
- Reliable operation at 150 bar (2.175 psi) continuous pumping pressure can be realized with Putzmeister Seat Valve (HSP) Piston Pumps.



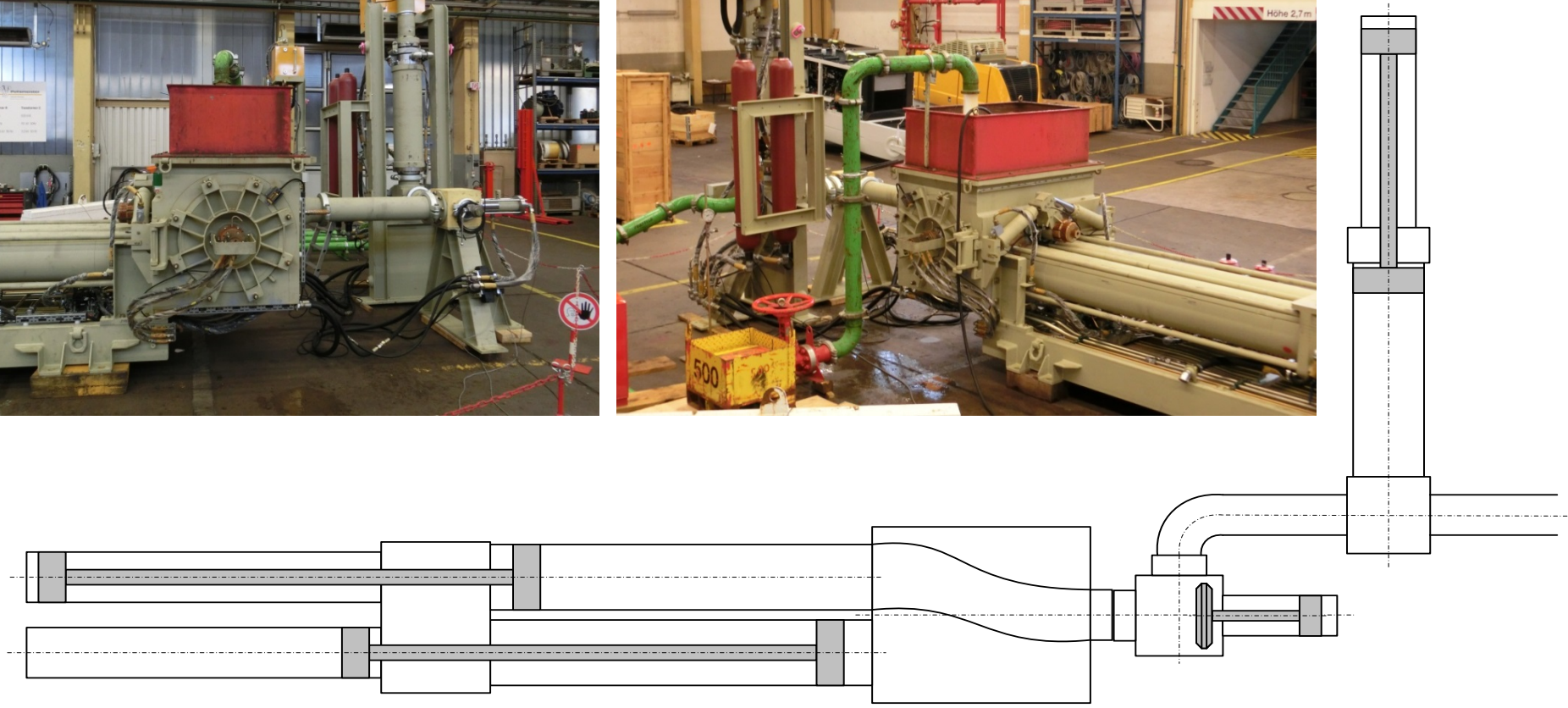

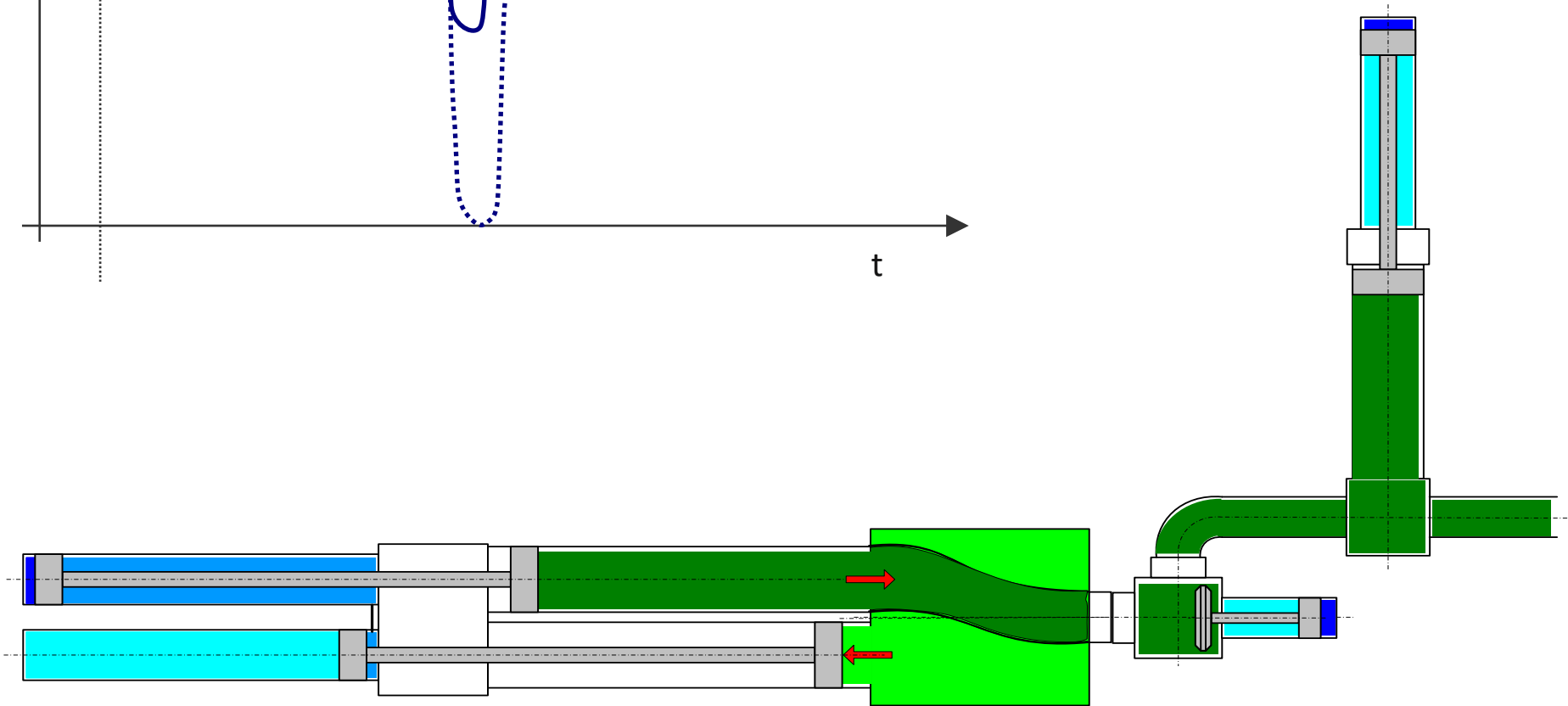
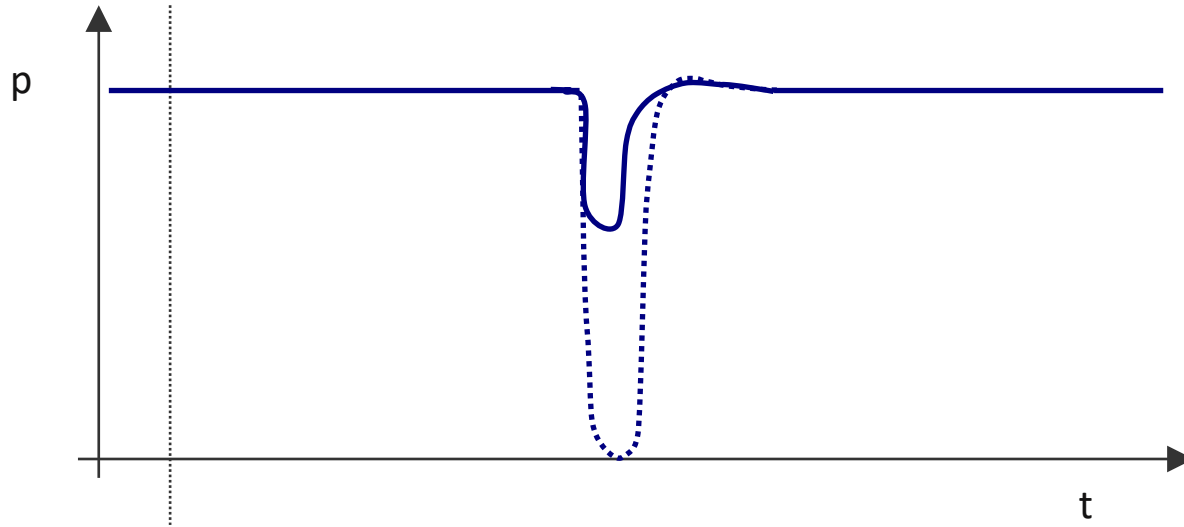

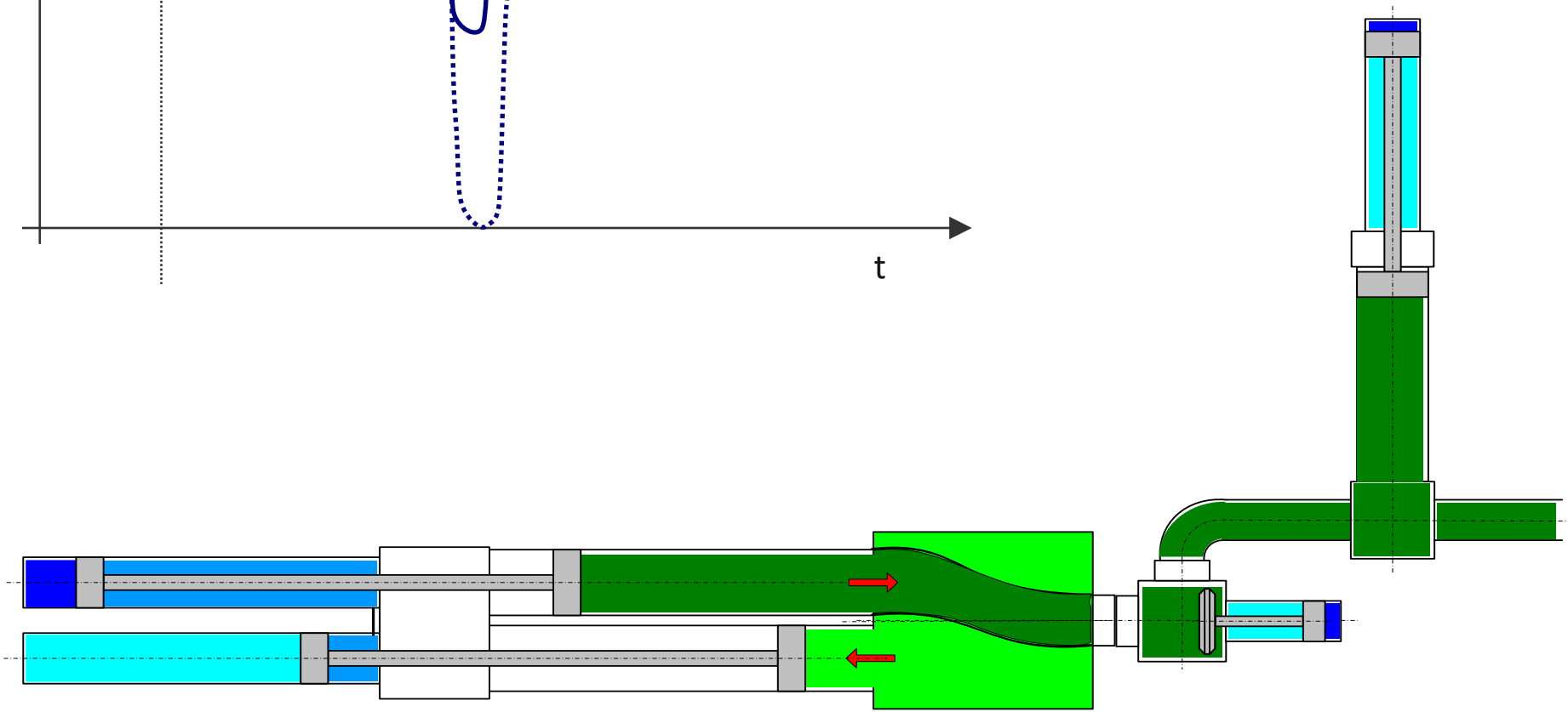
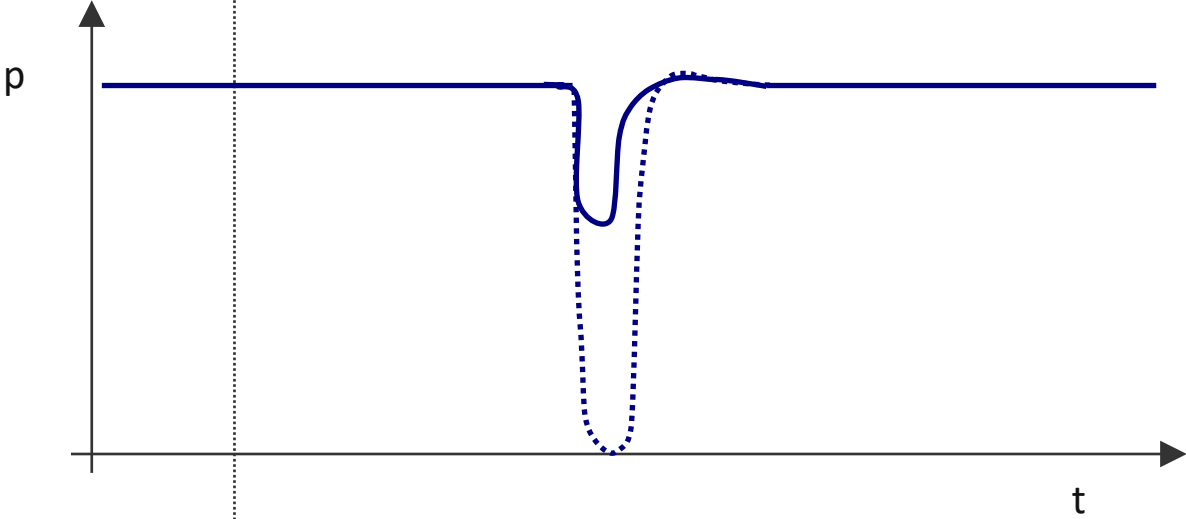

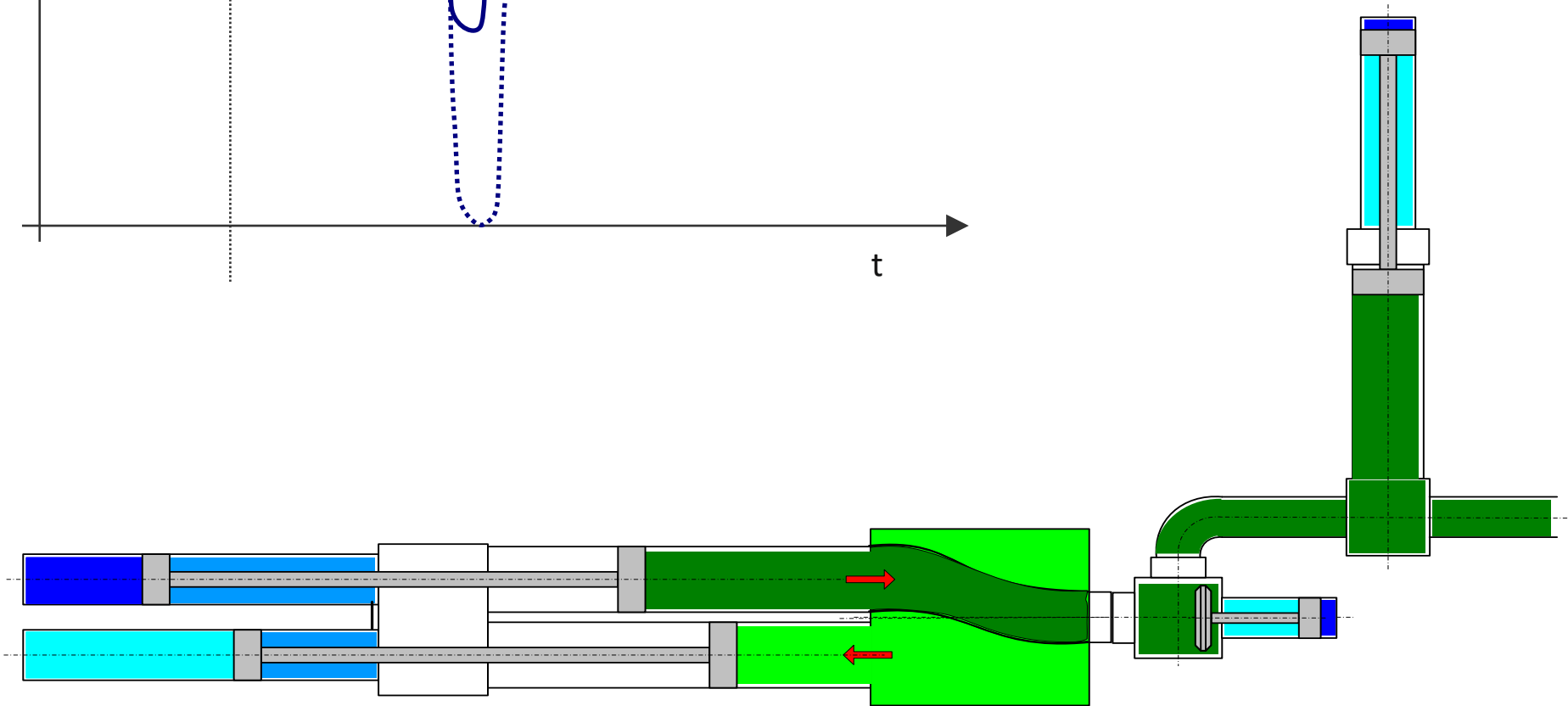
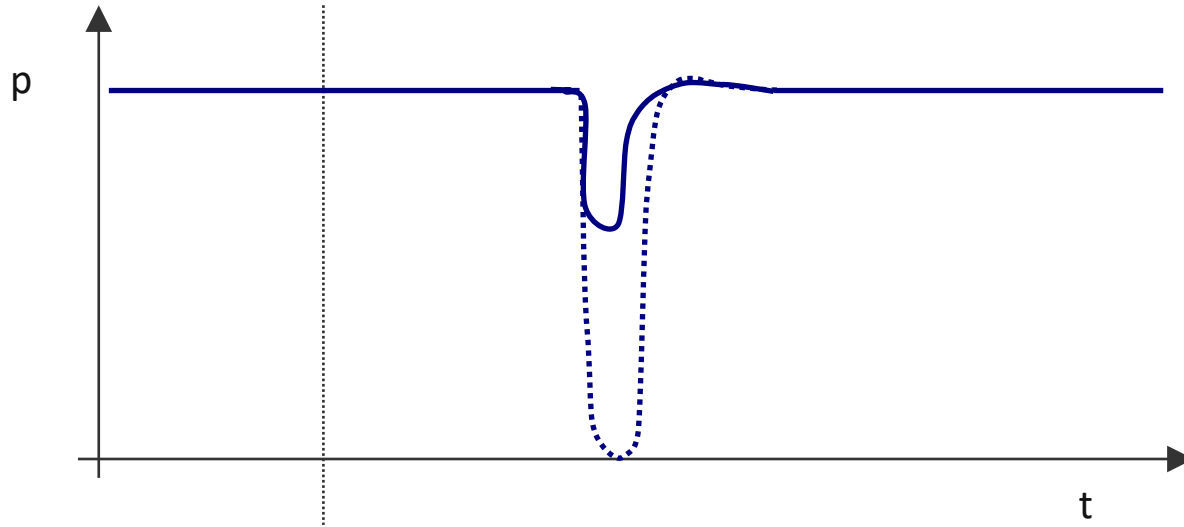

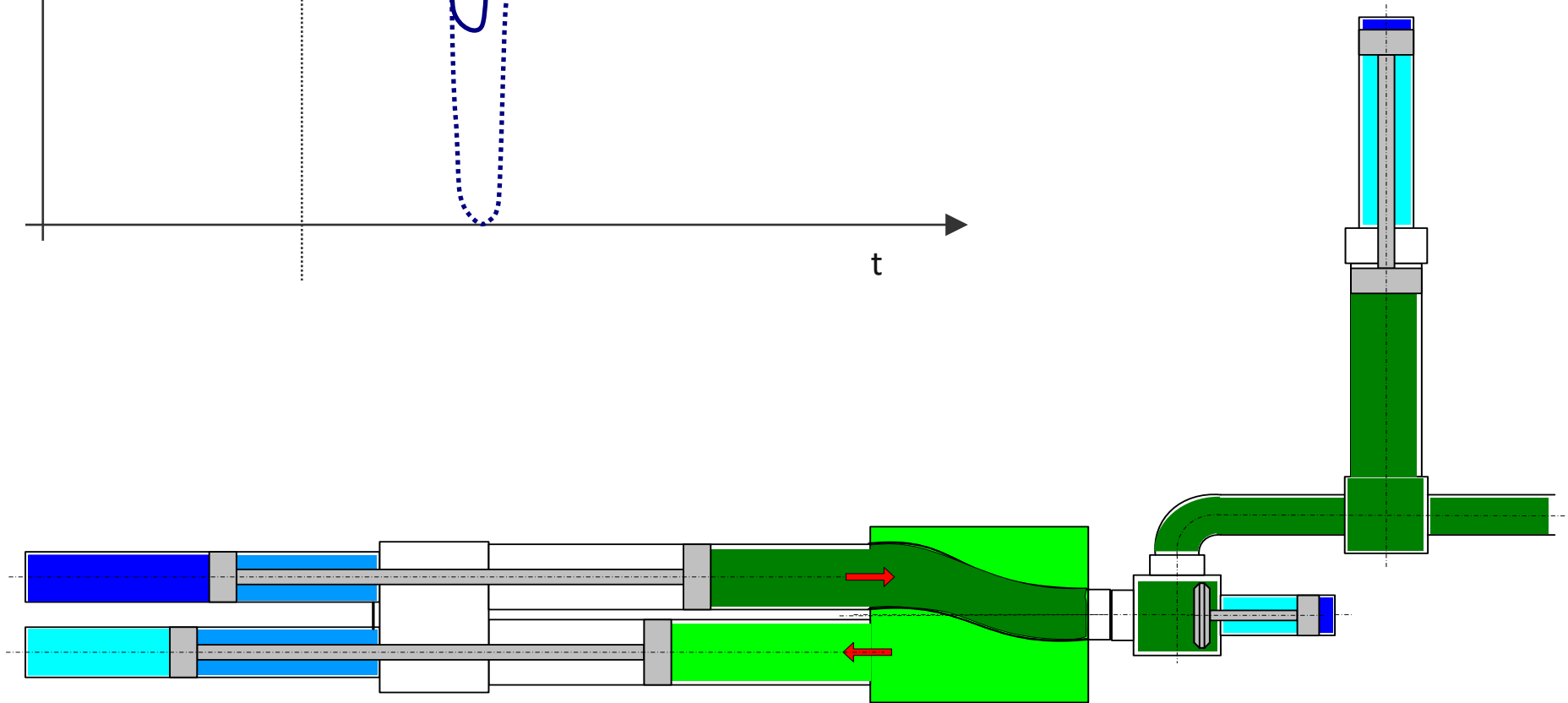
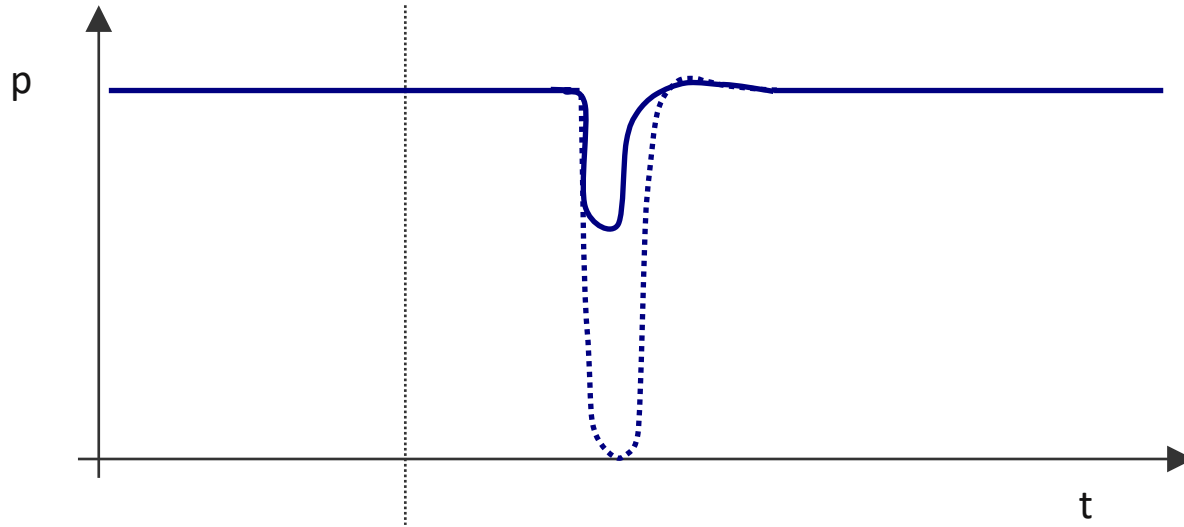

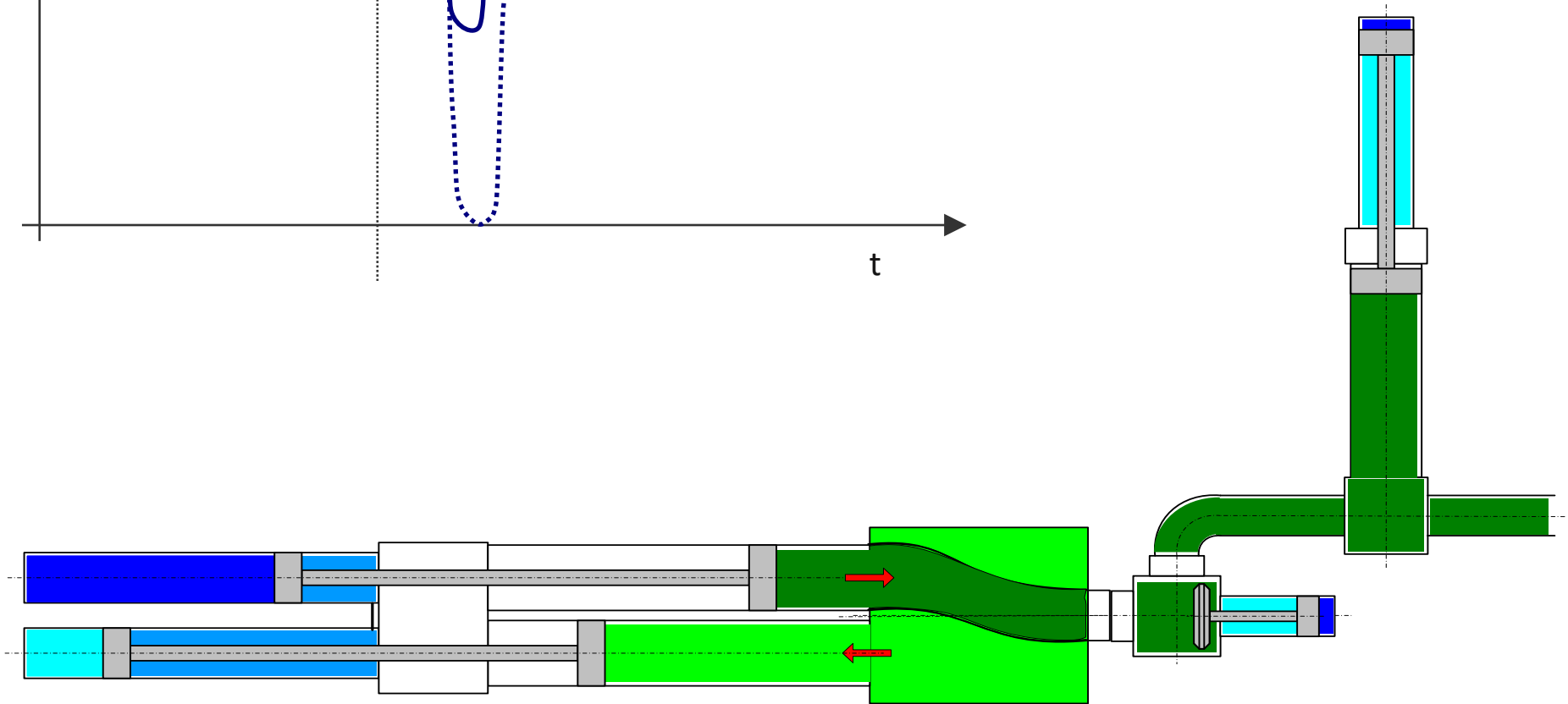
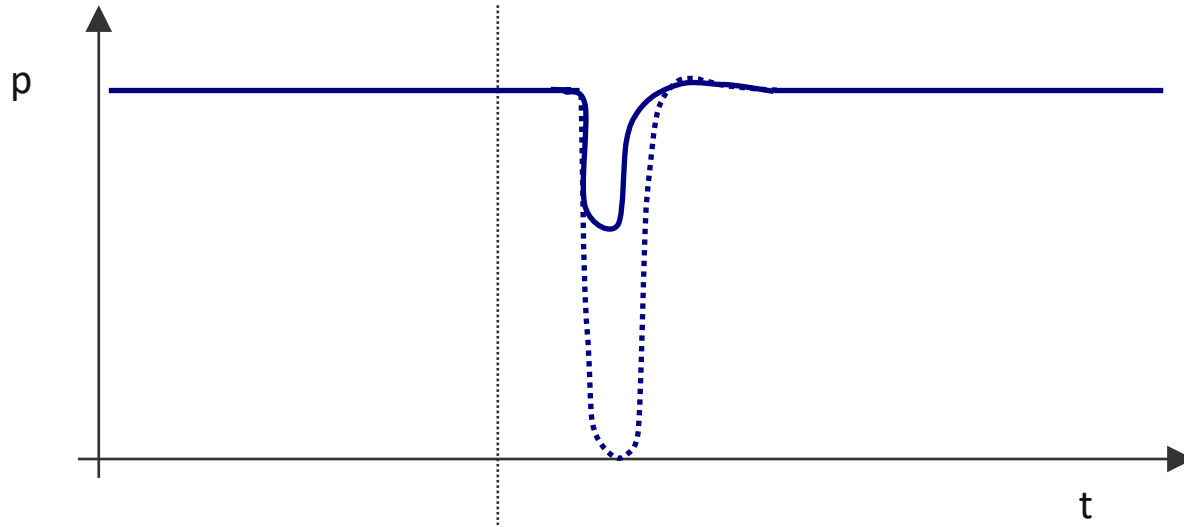

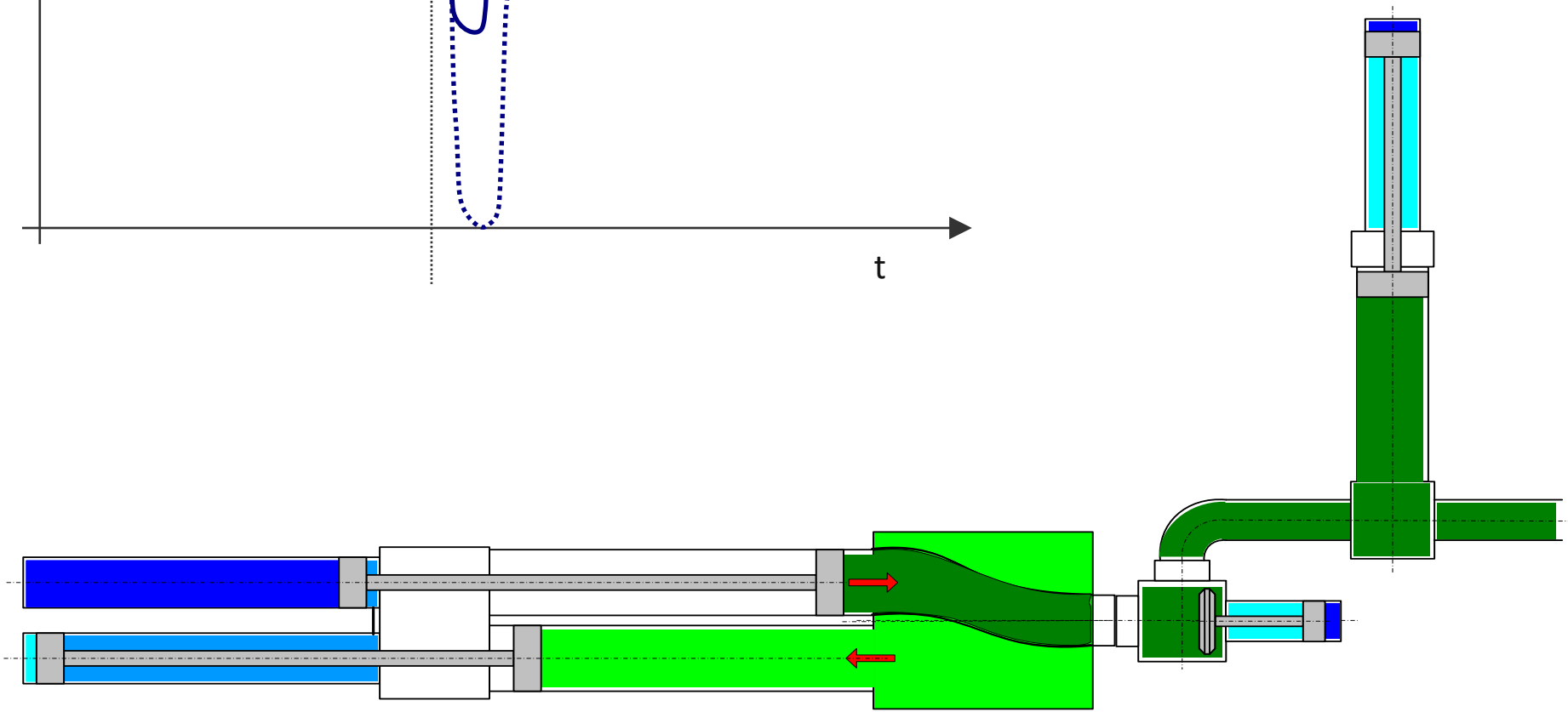
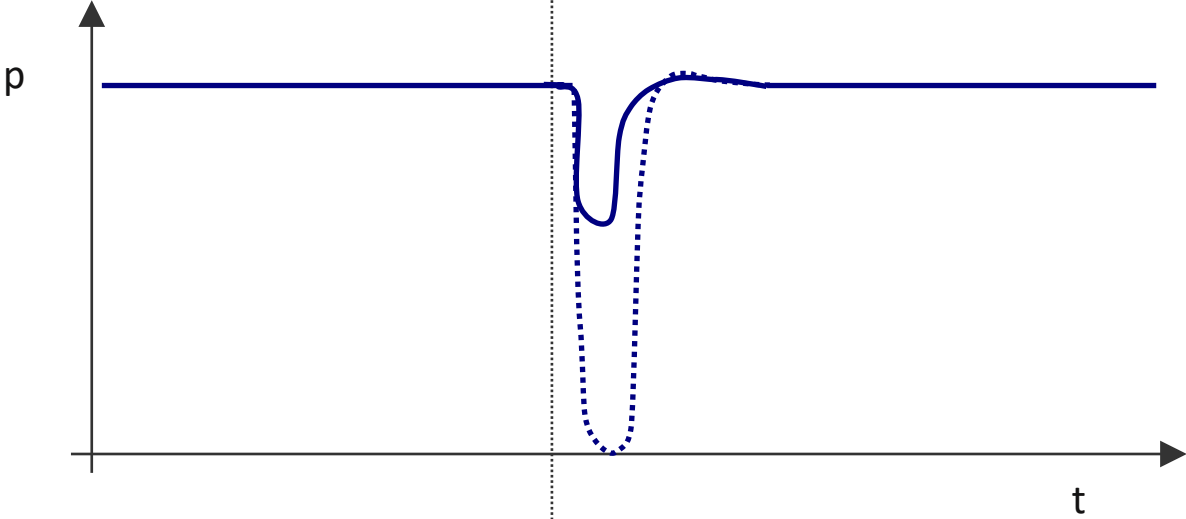

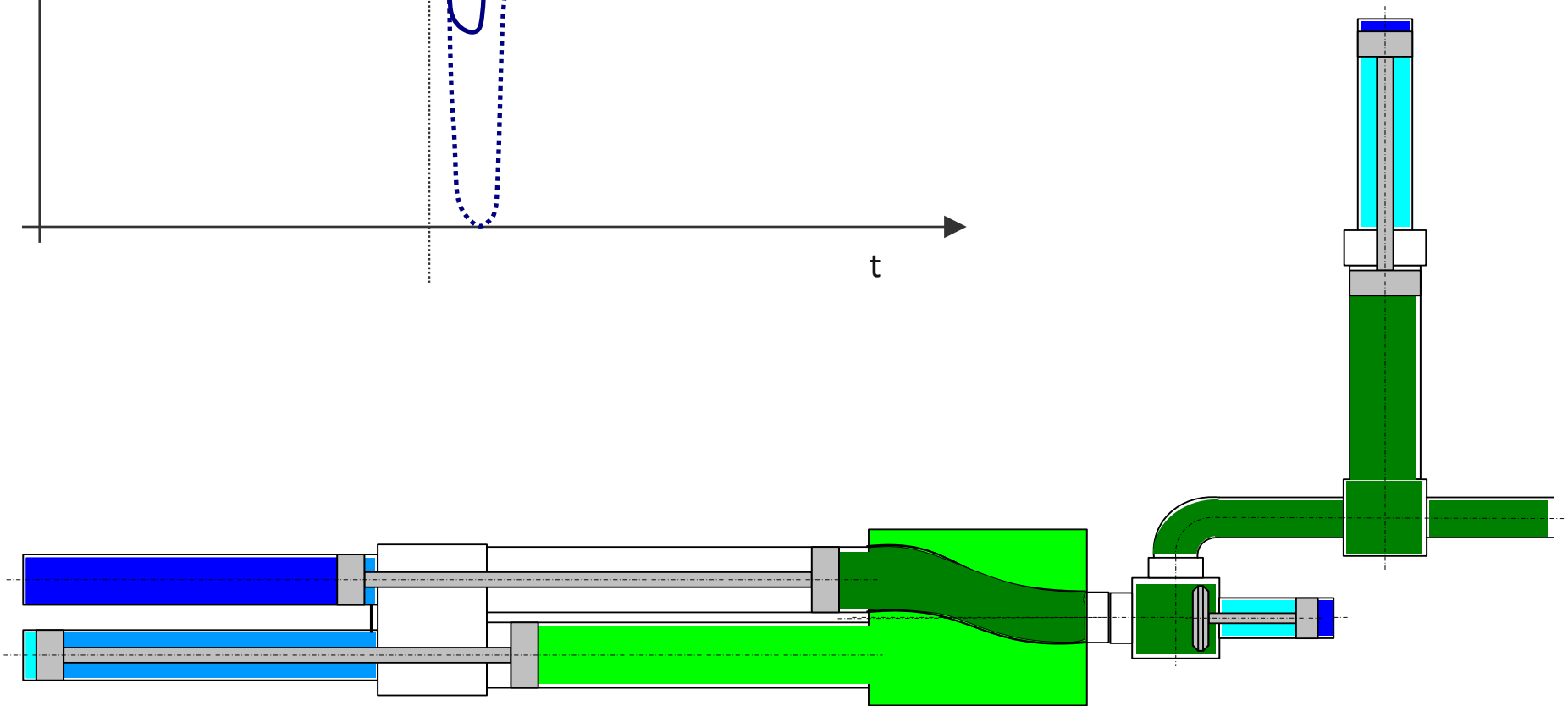
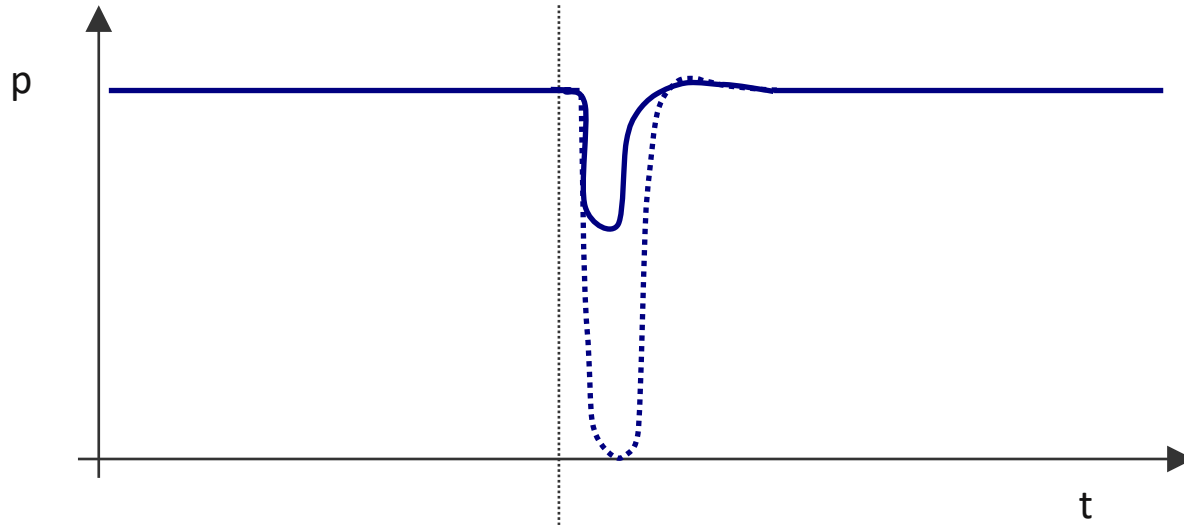

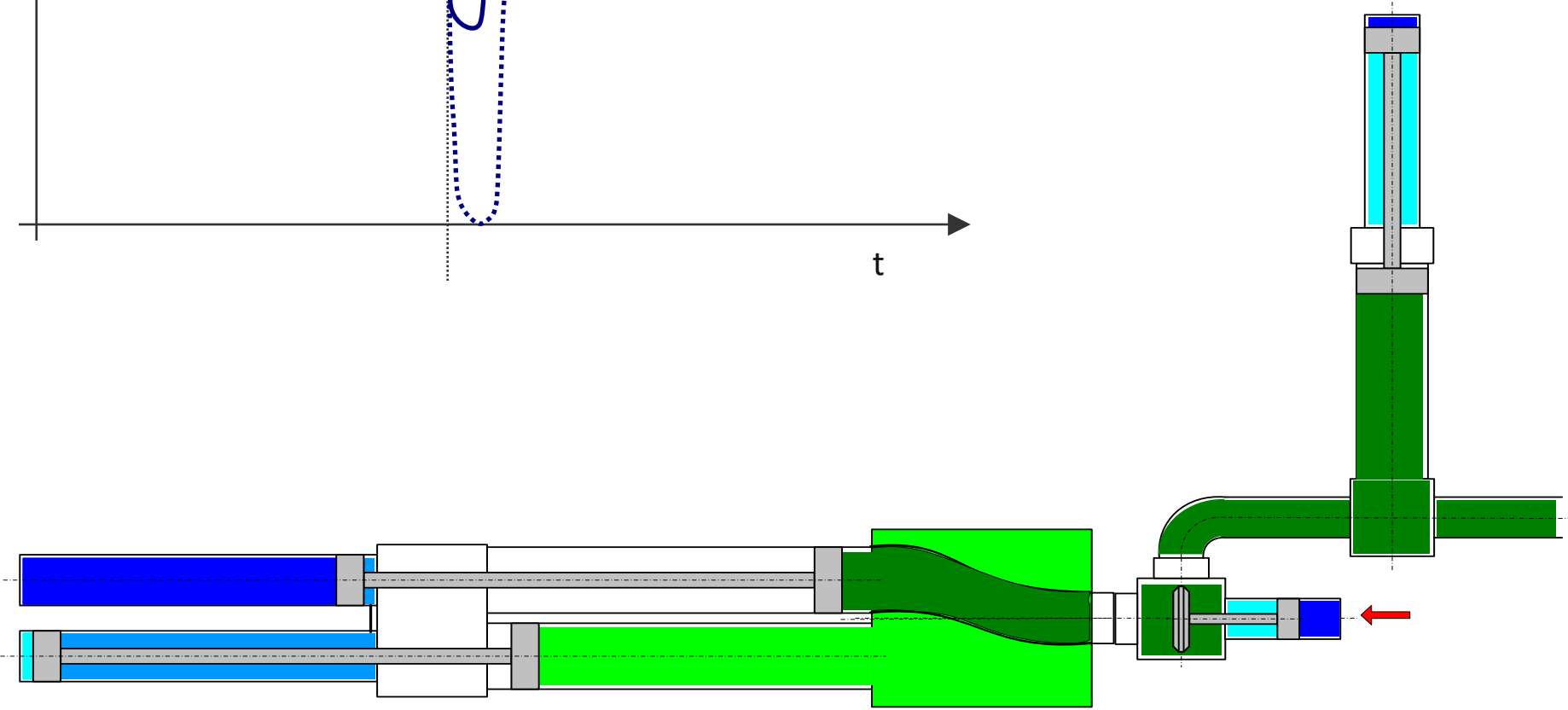
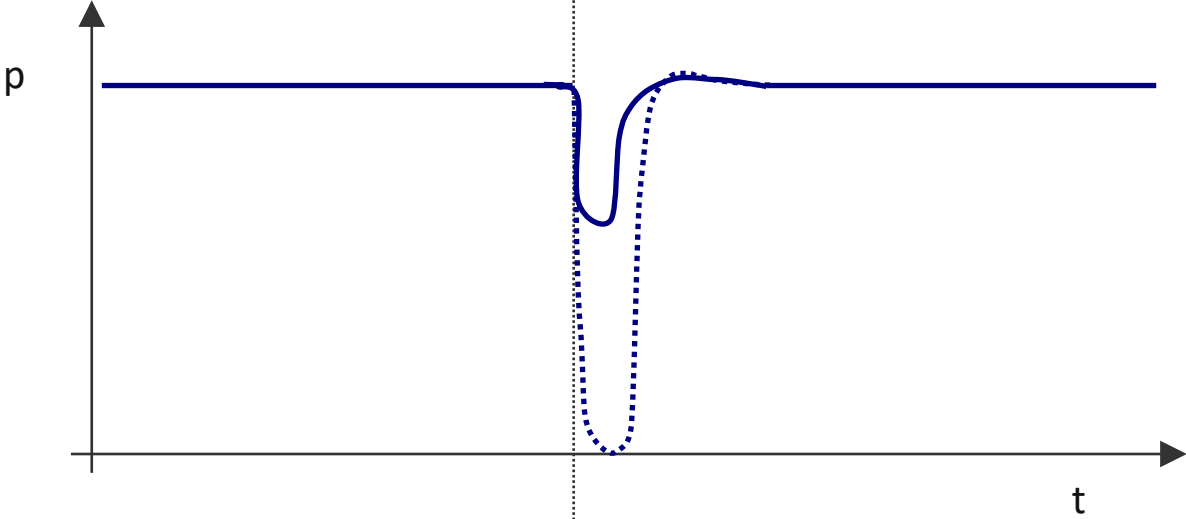

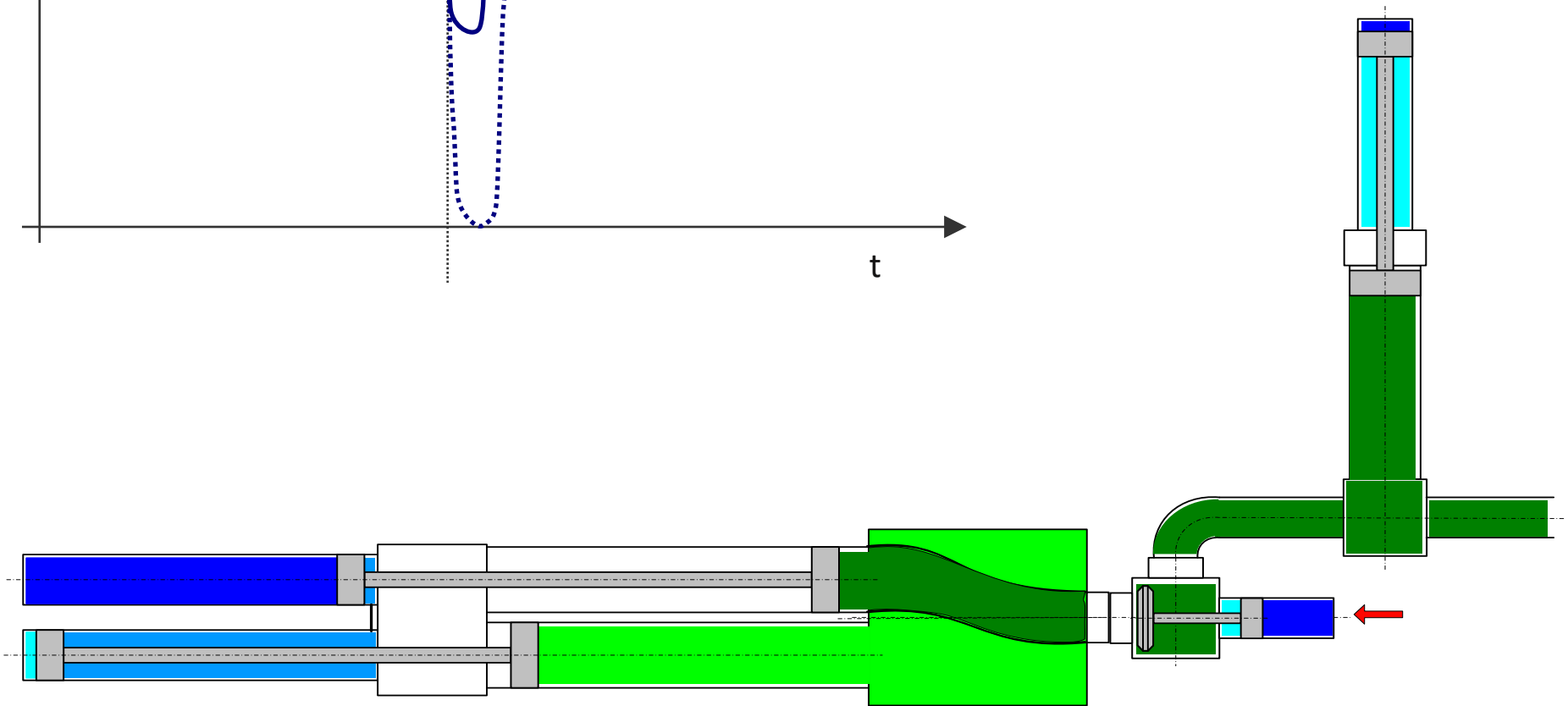
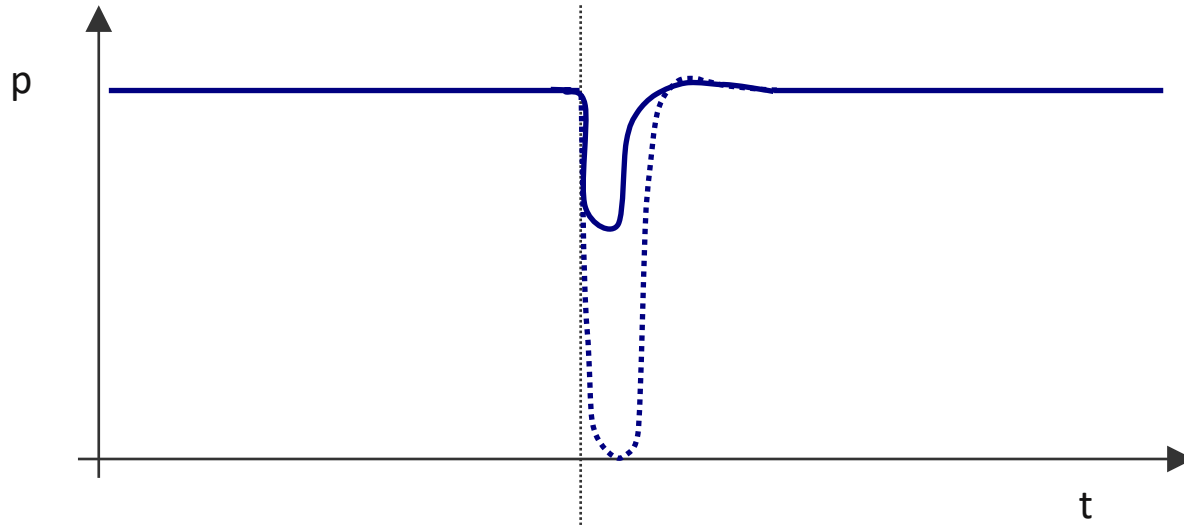

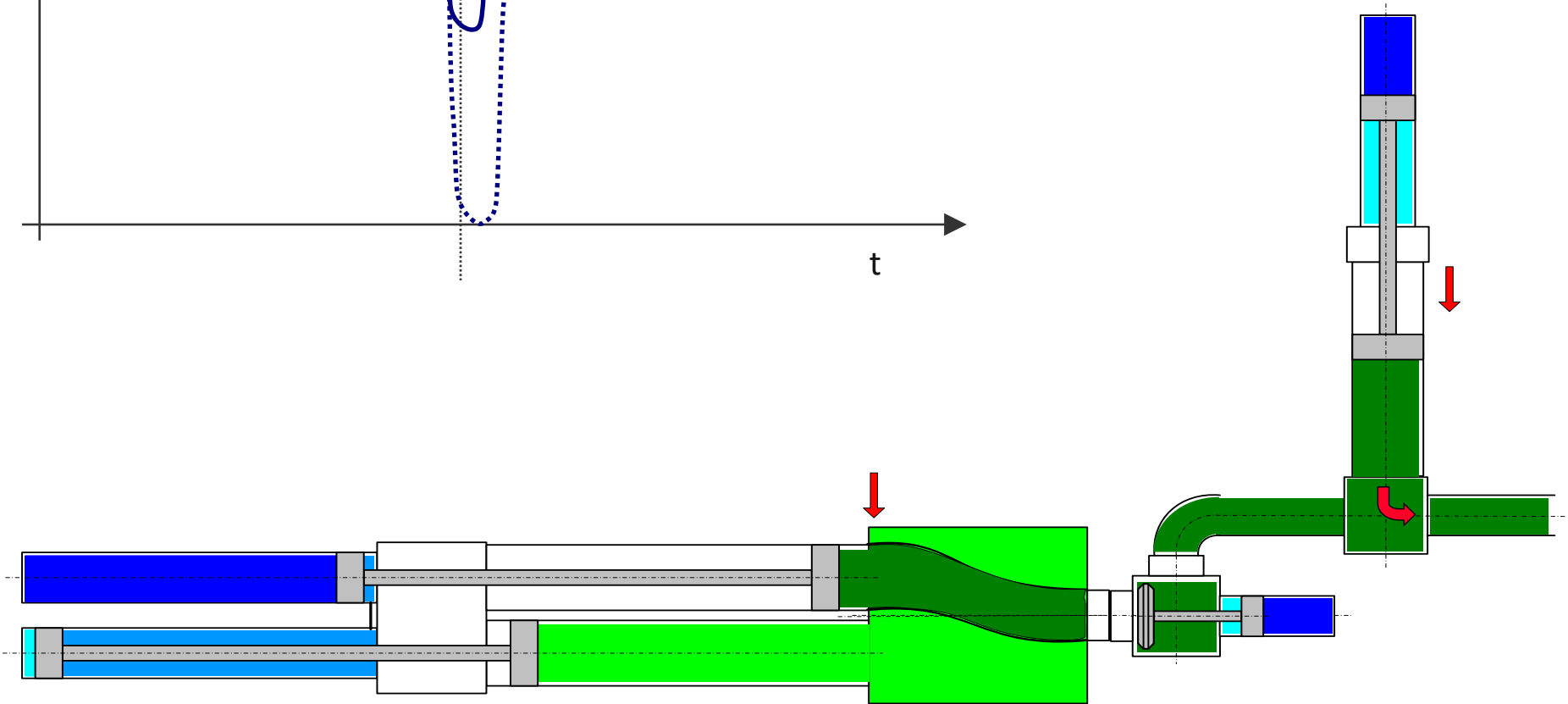
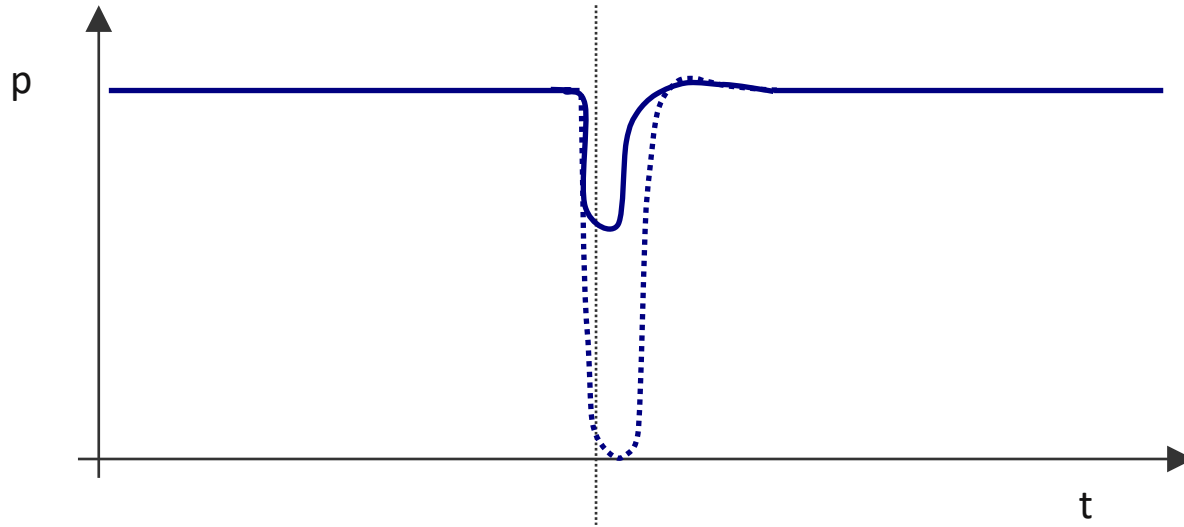

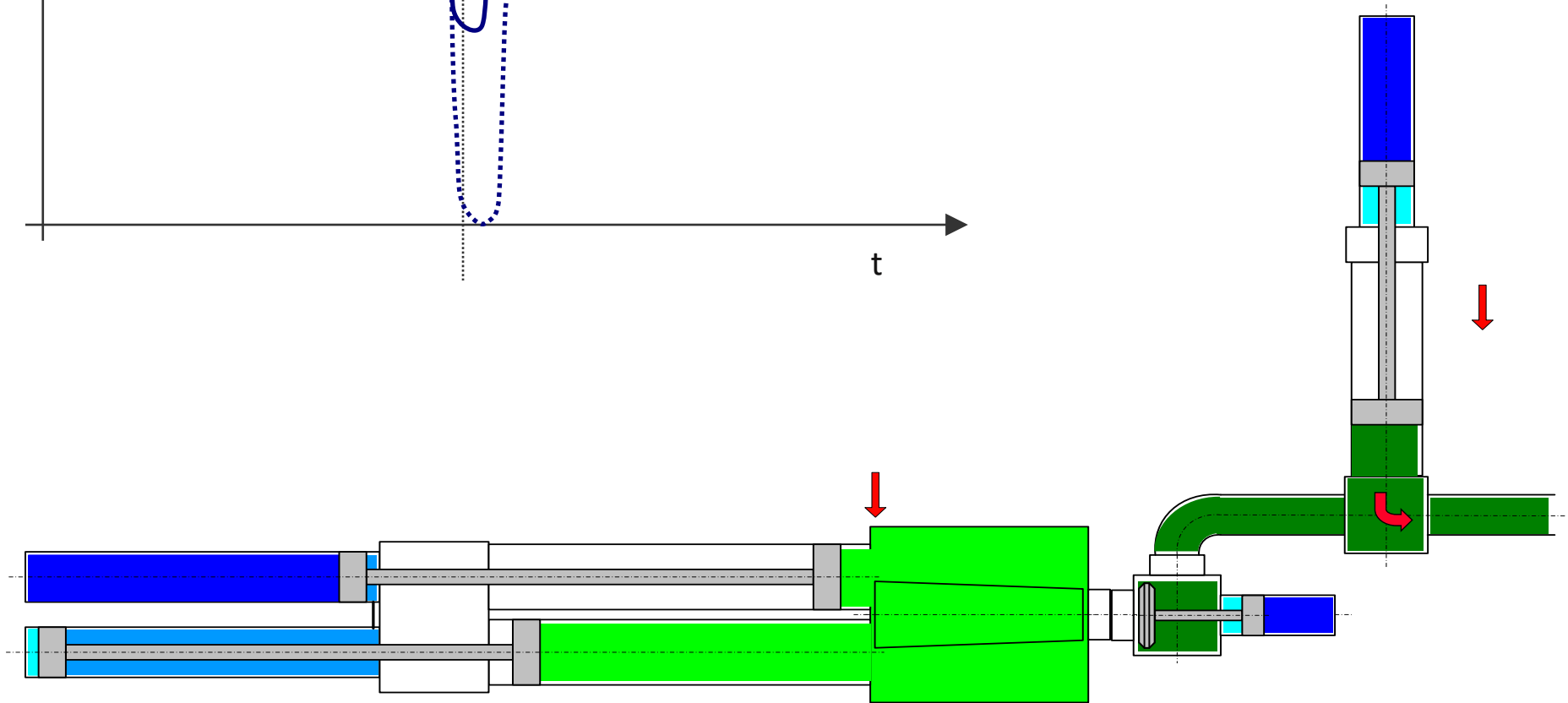
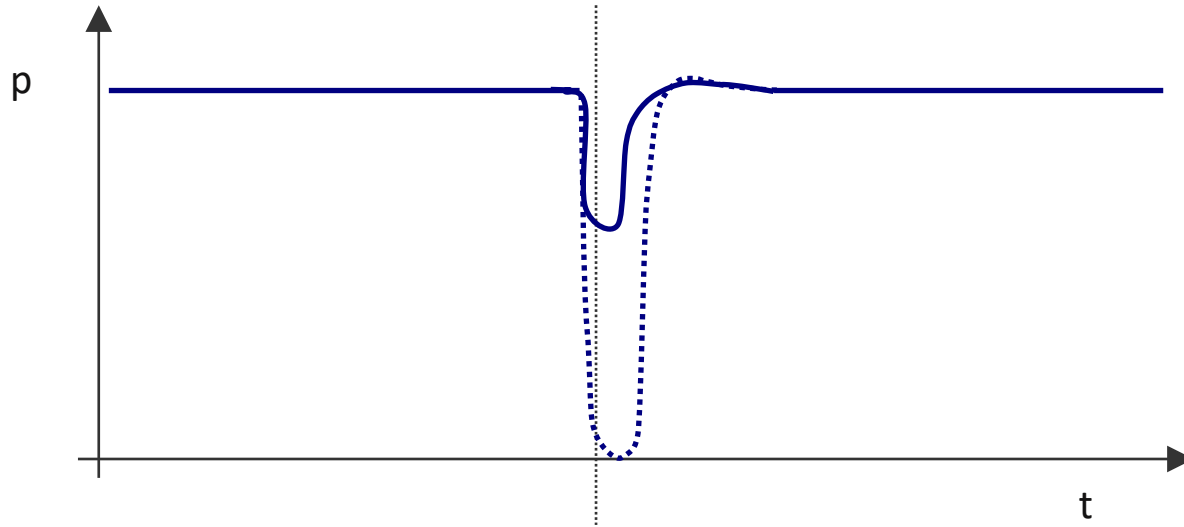

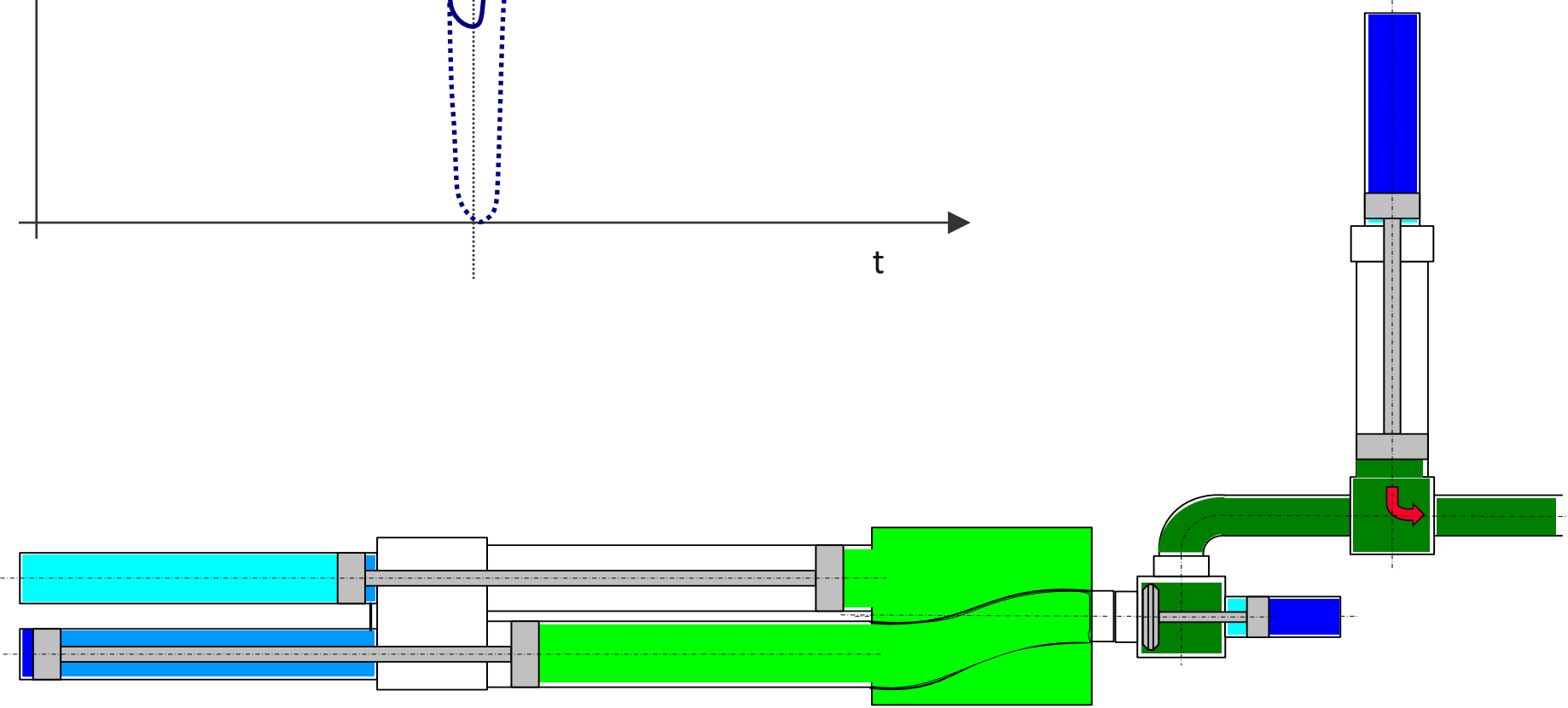
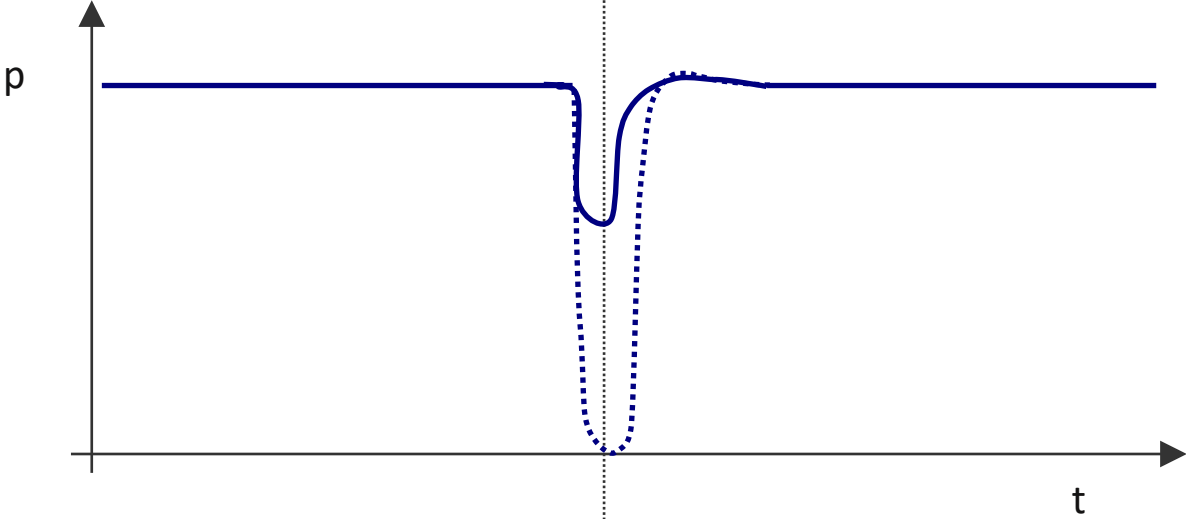

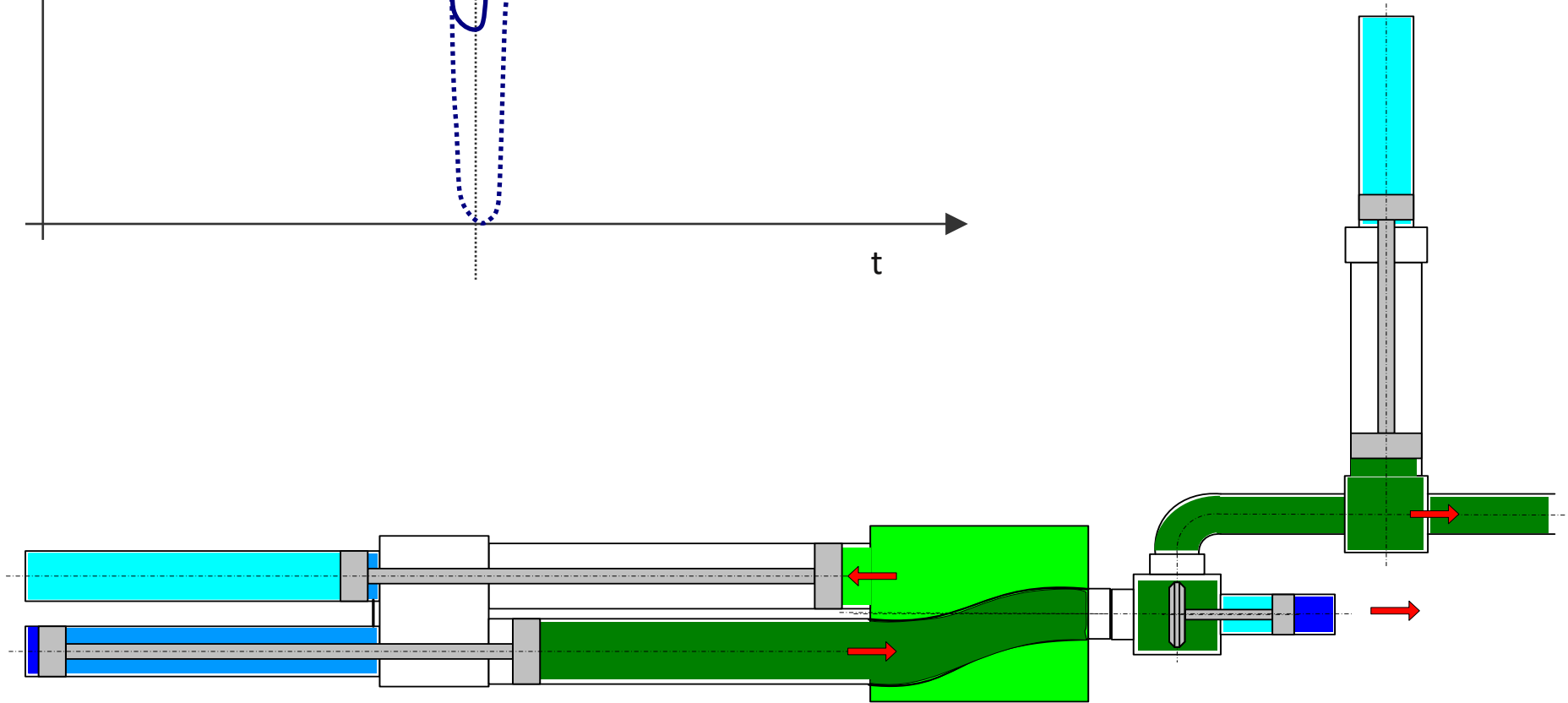
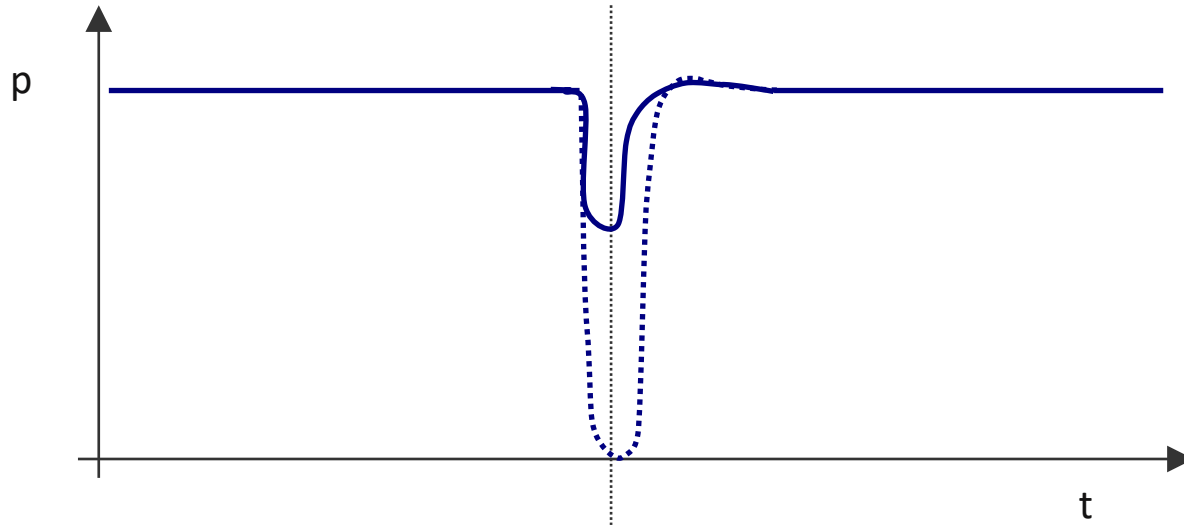

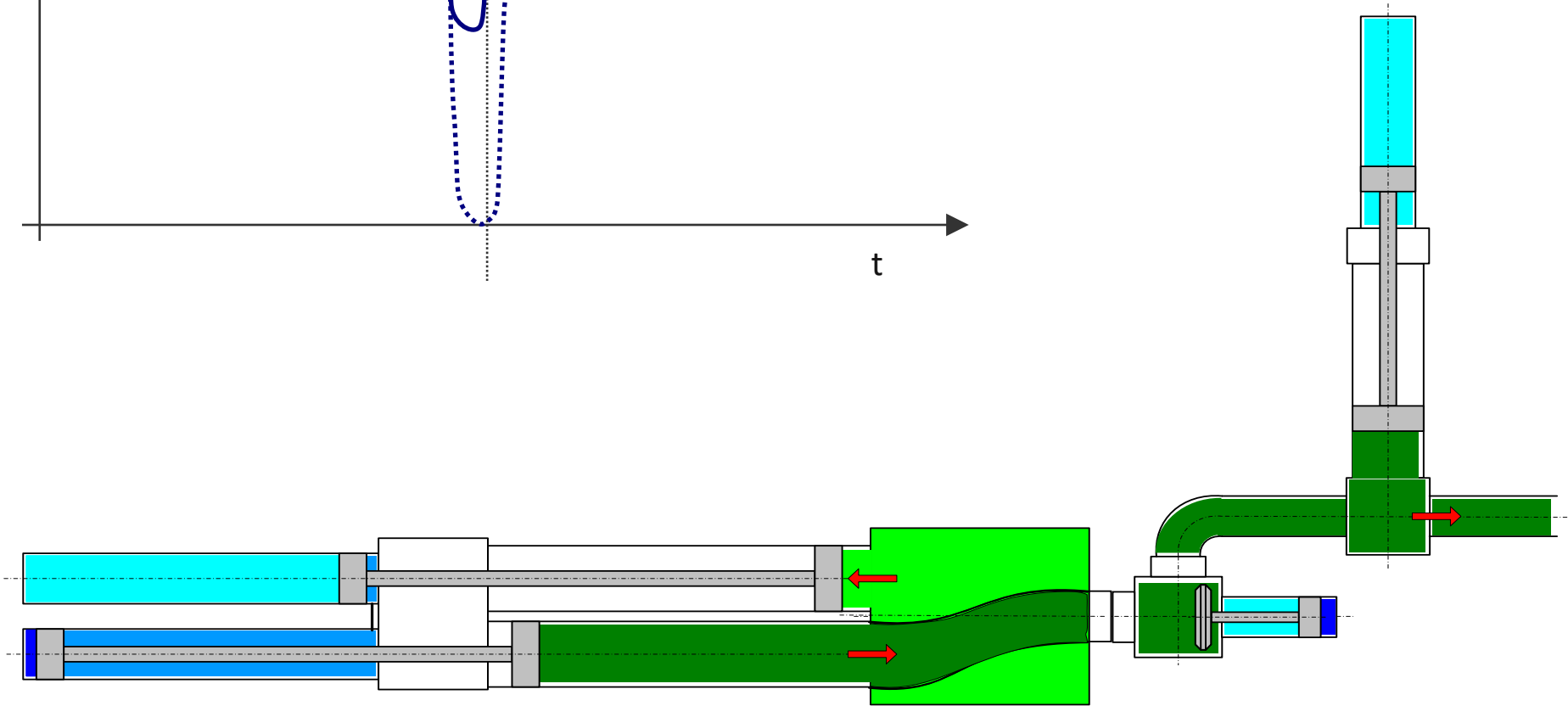
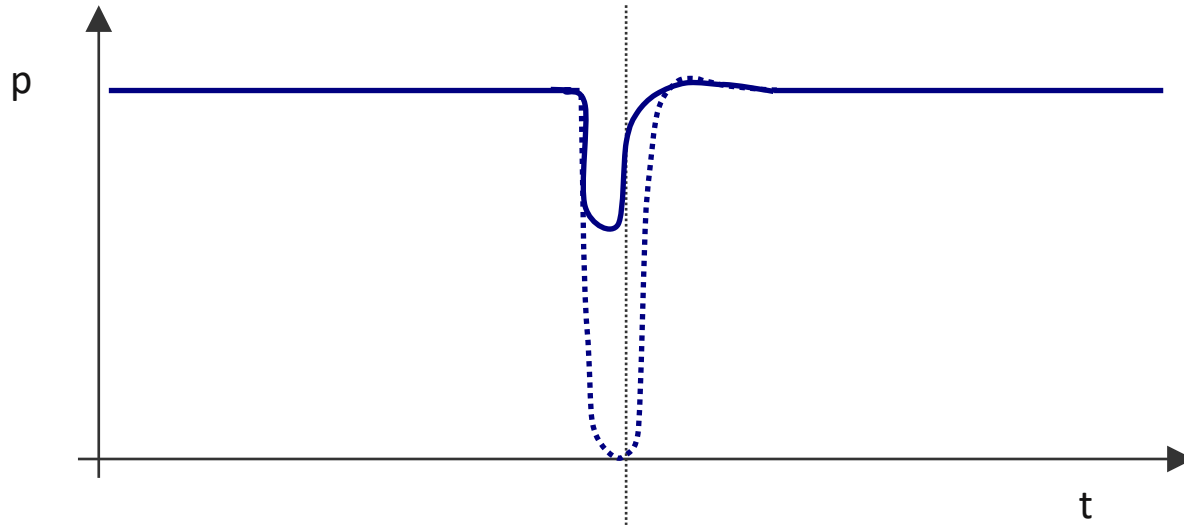

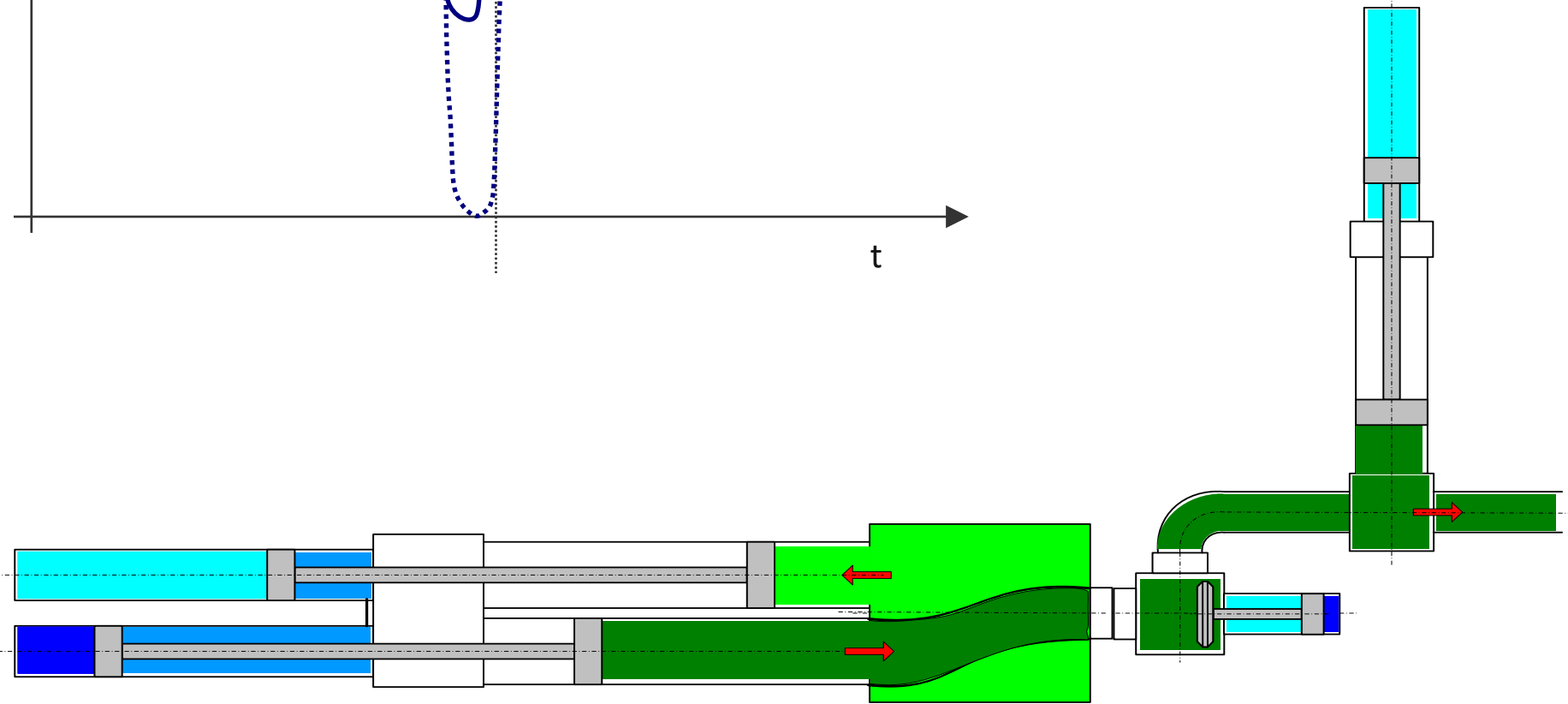
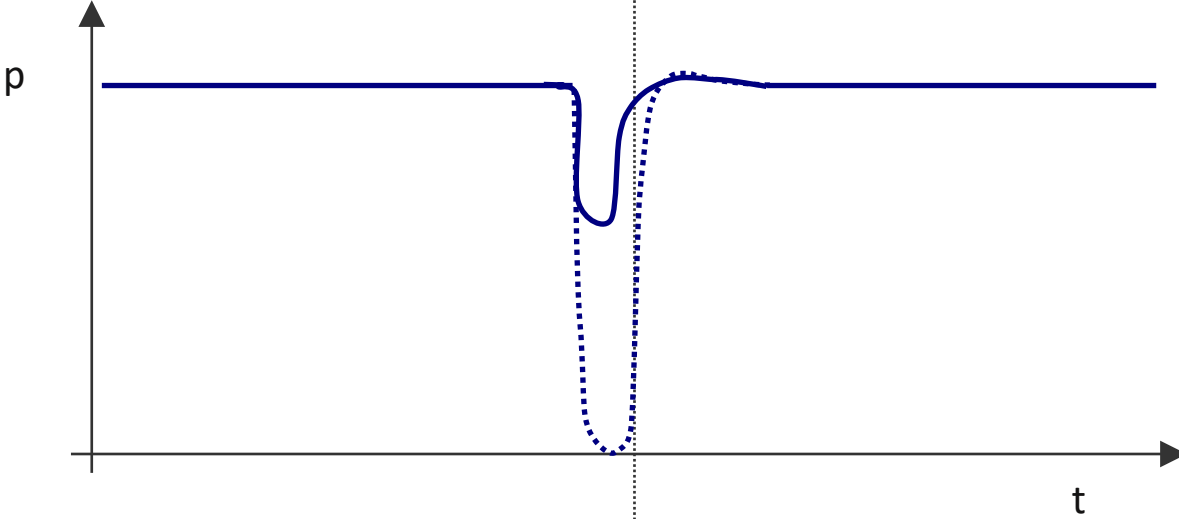

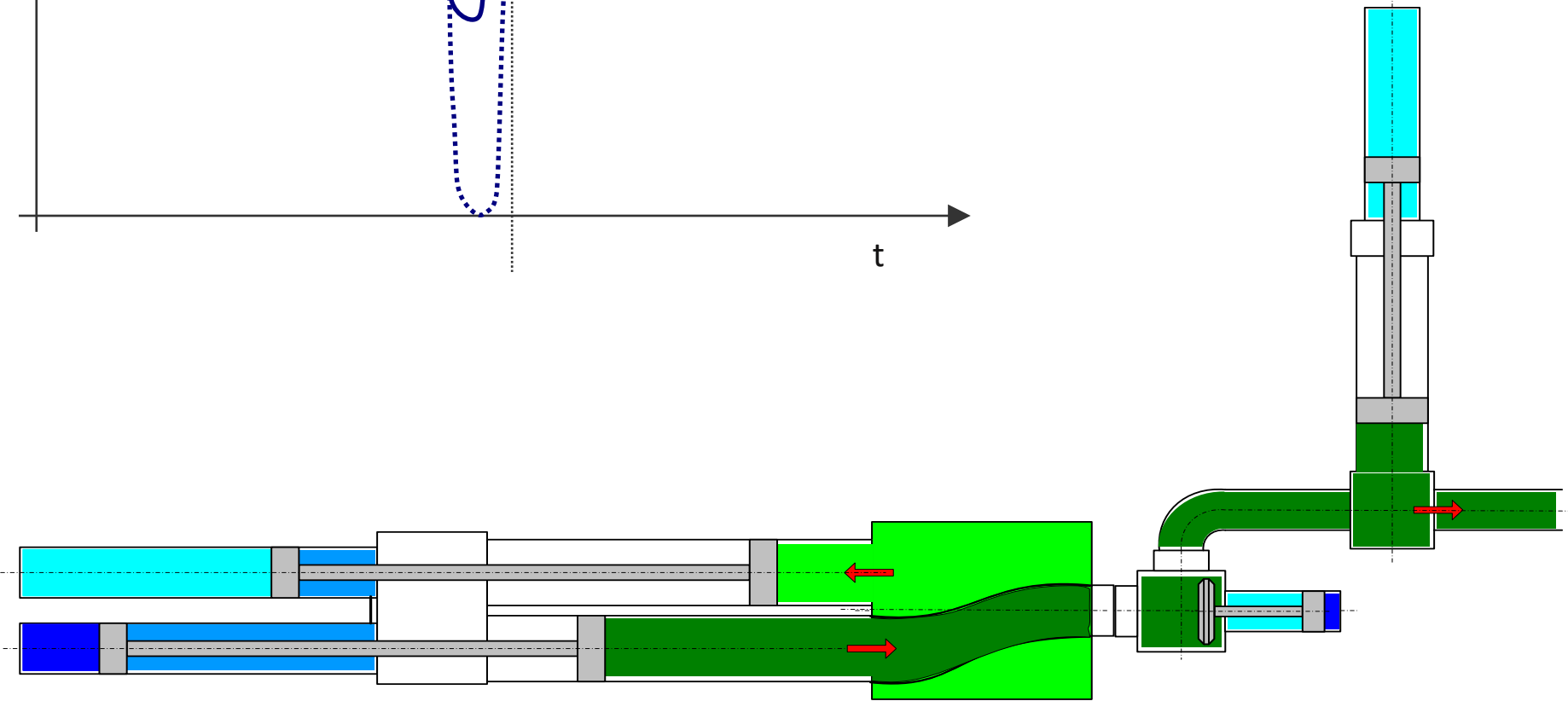
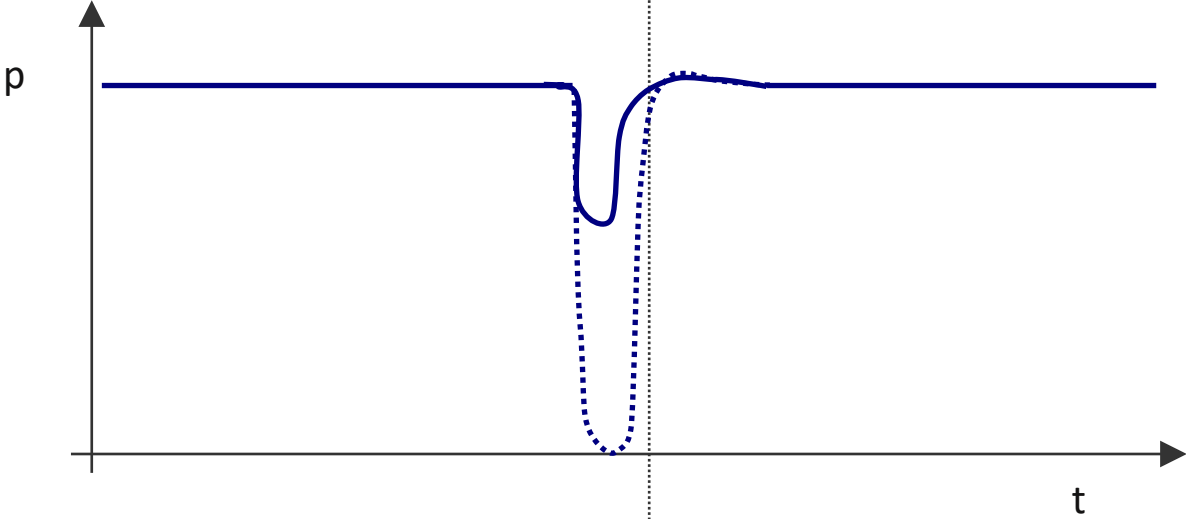

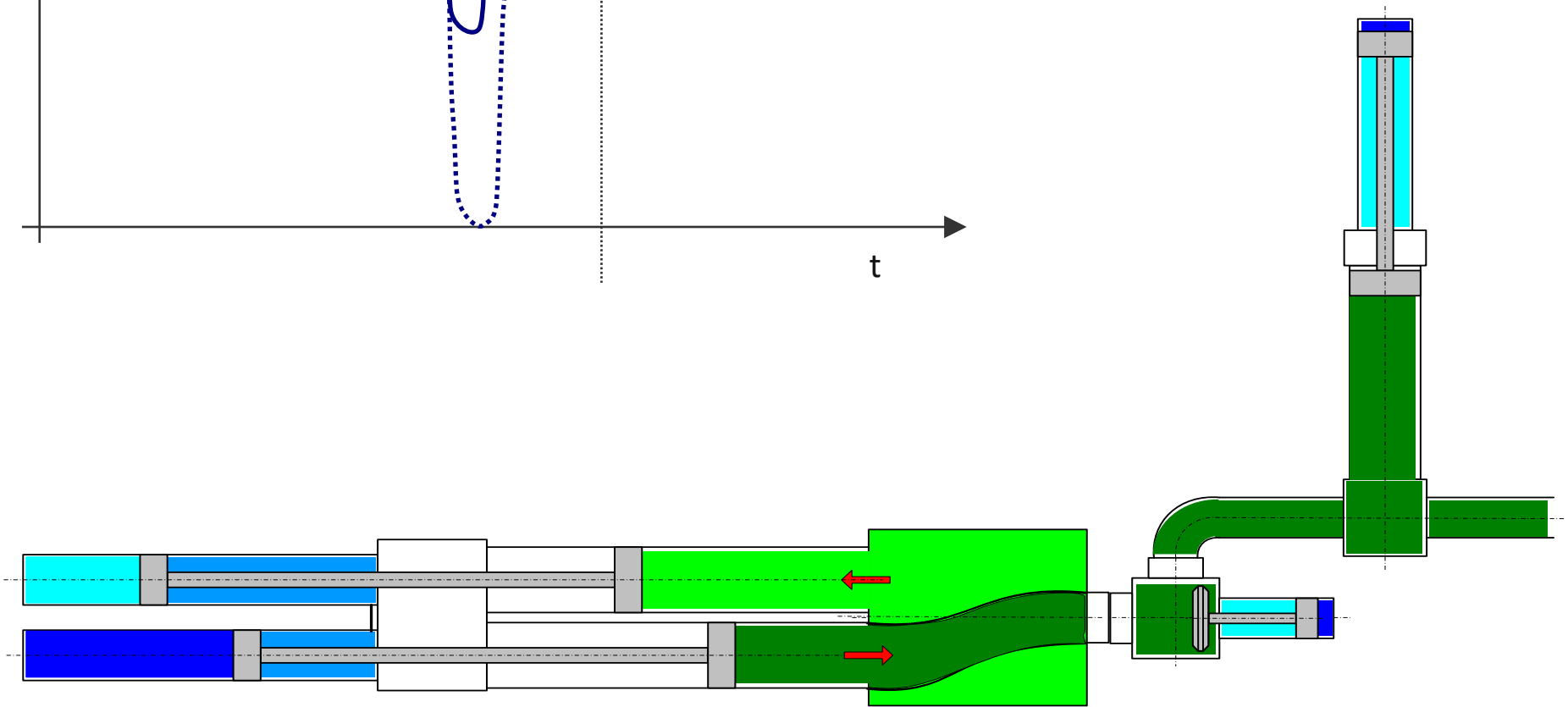
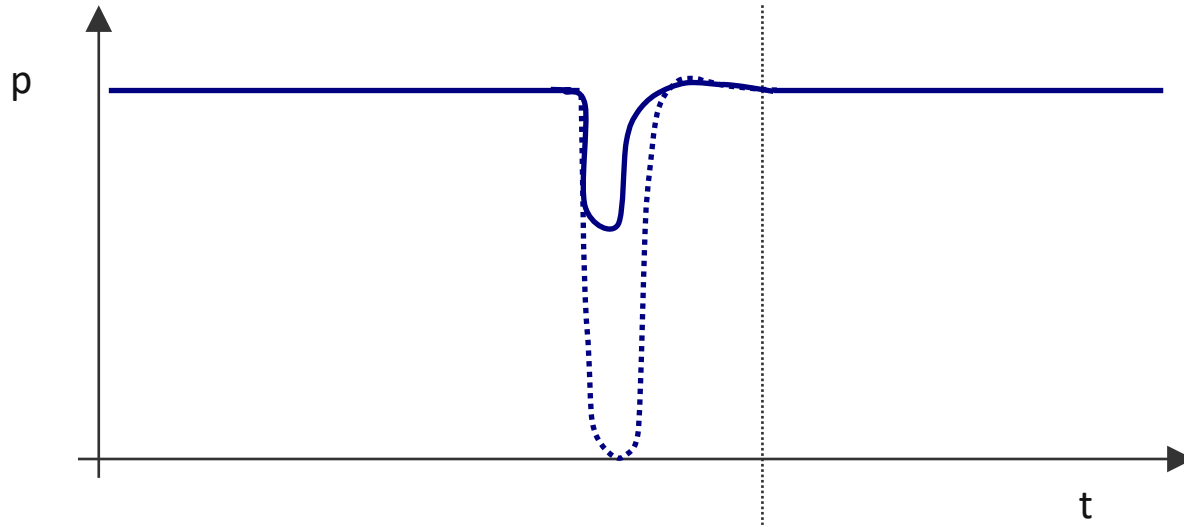

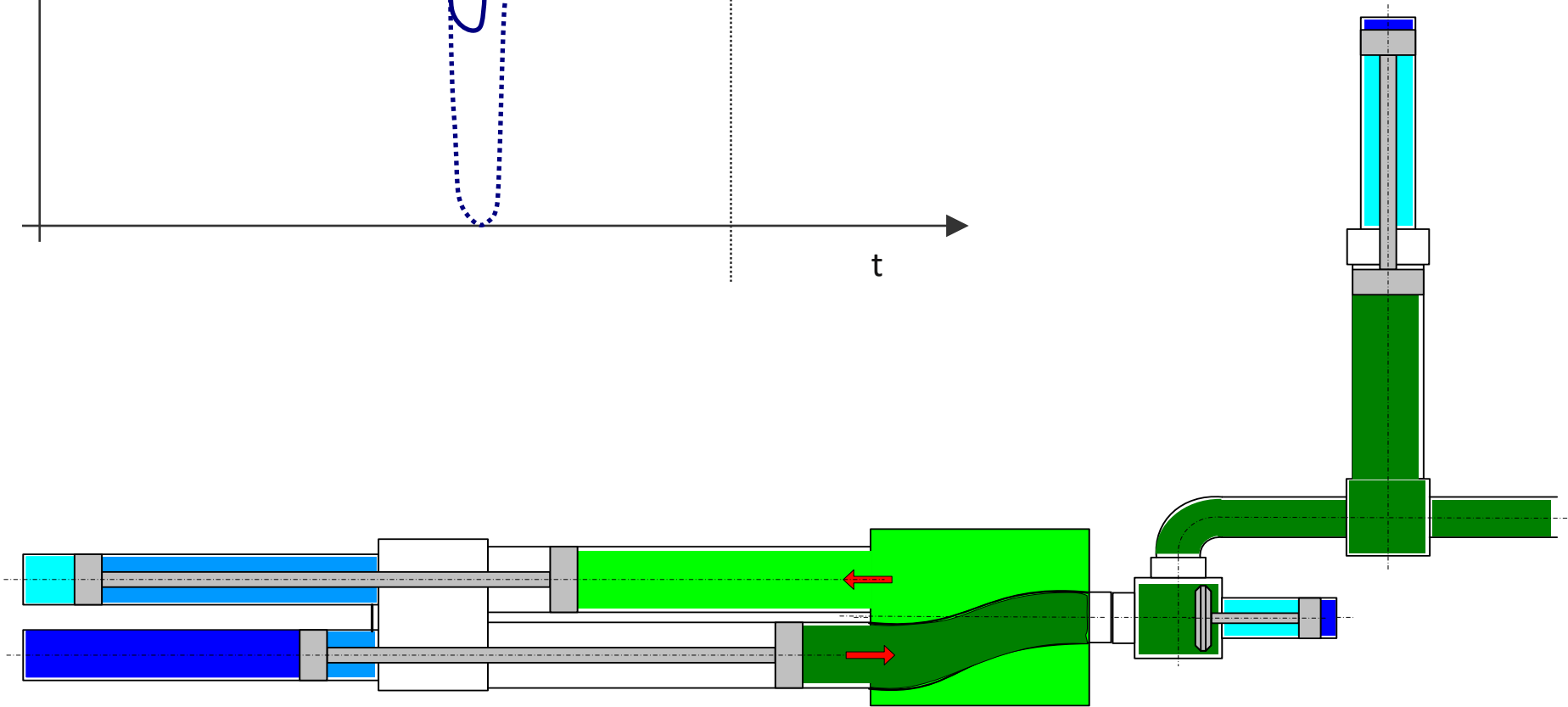
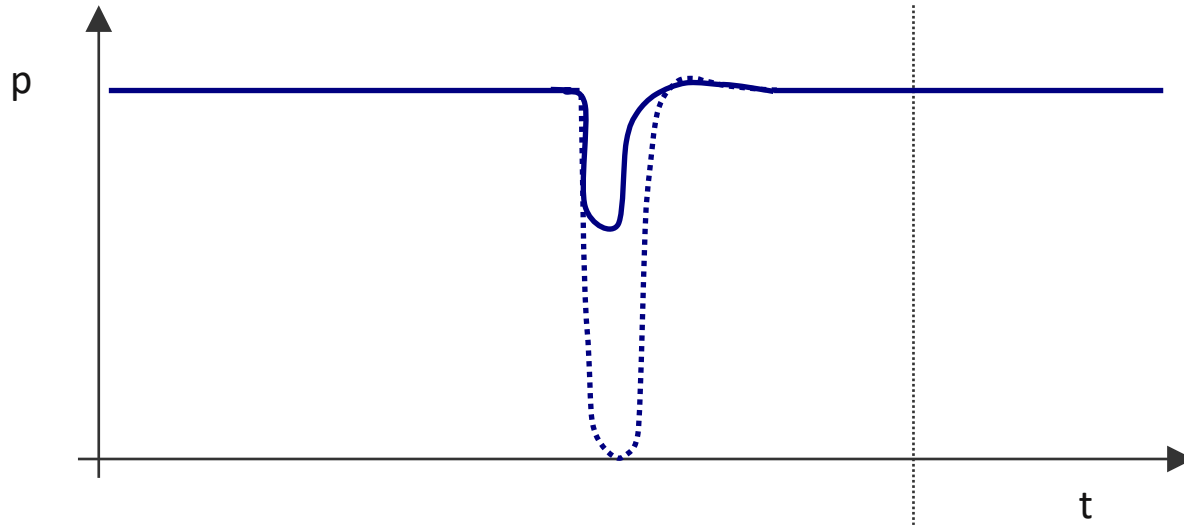

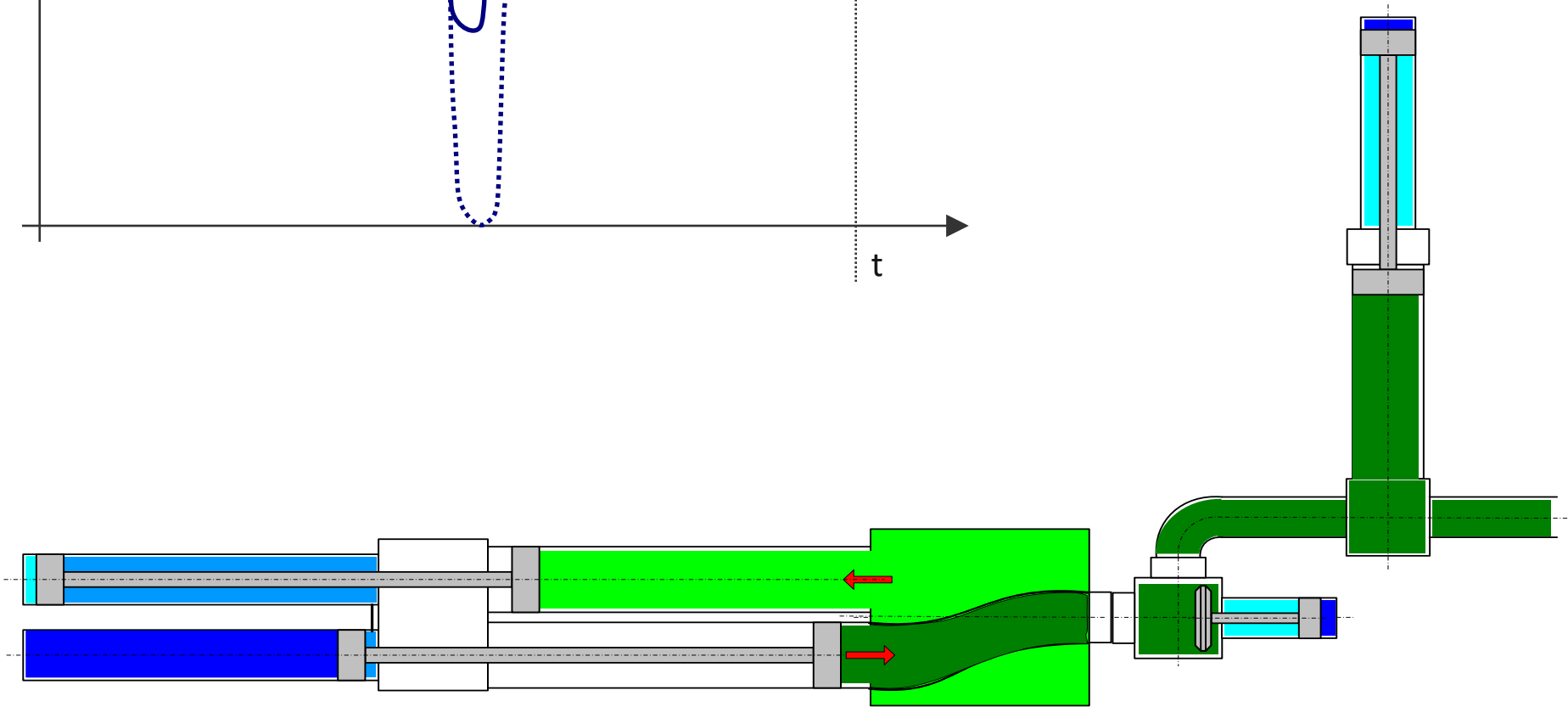
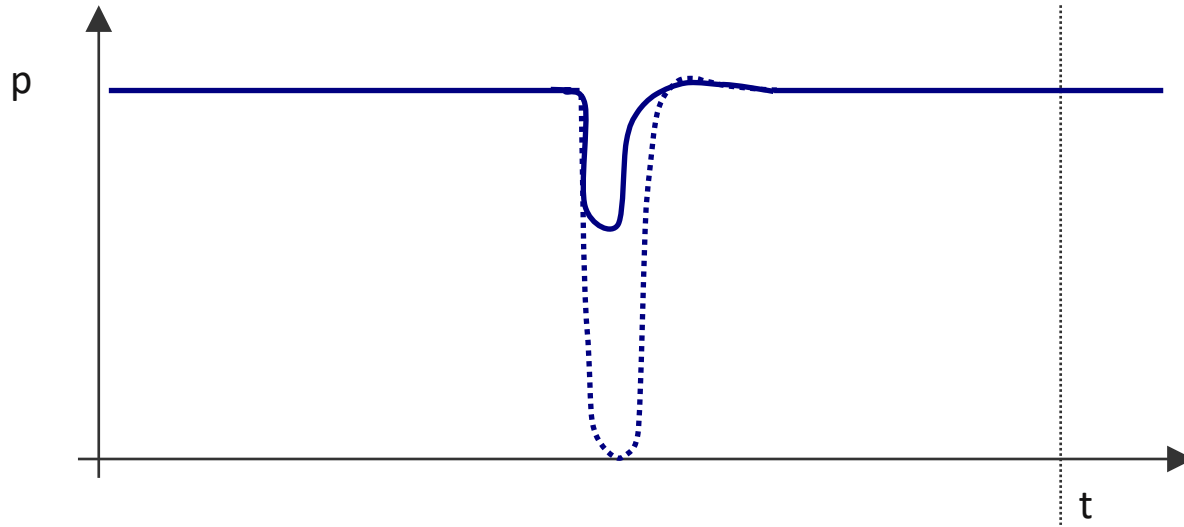



KOS + HPD in operation on the Testfield

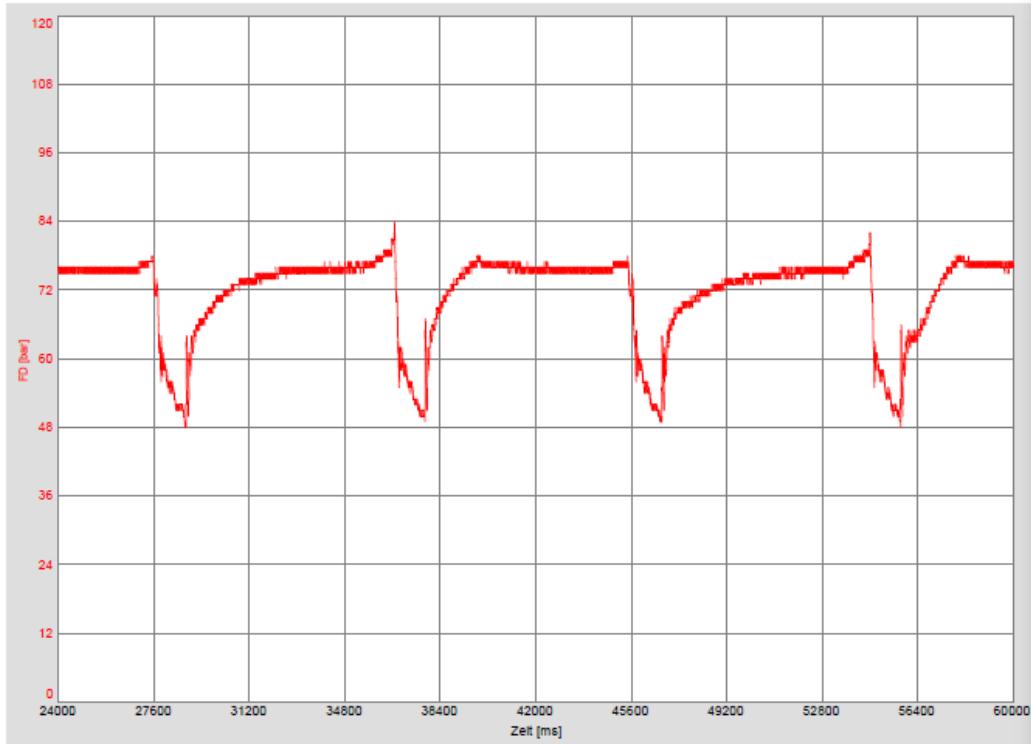

Pressure Curve



Pressure reading in the Pipeline

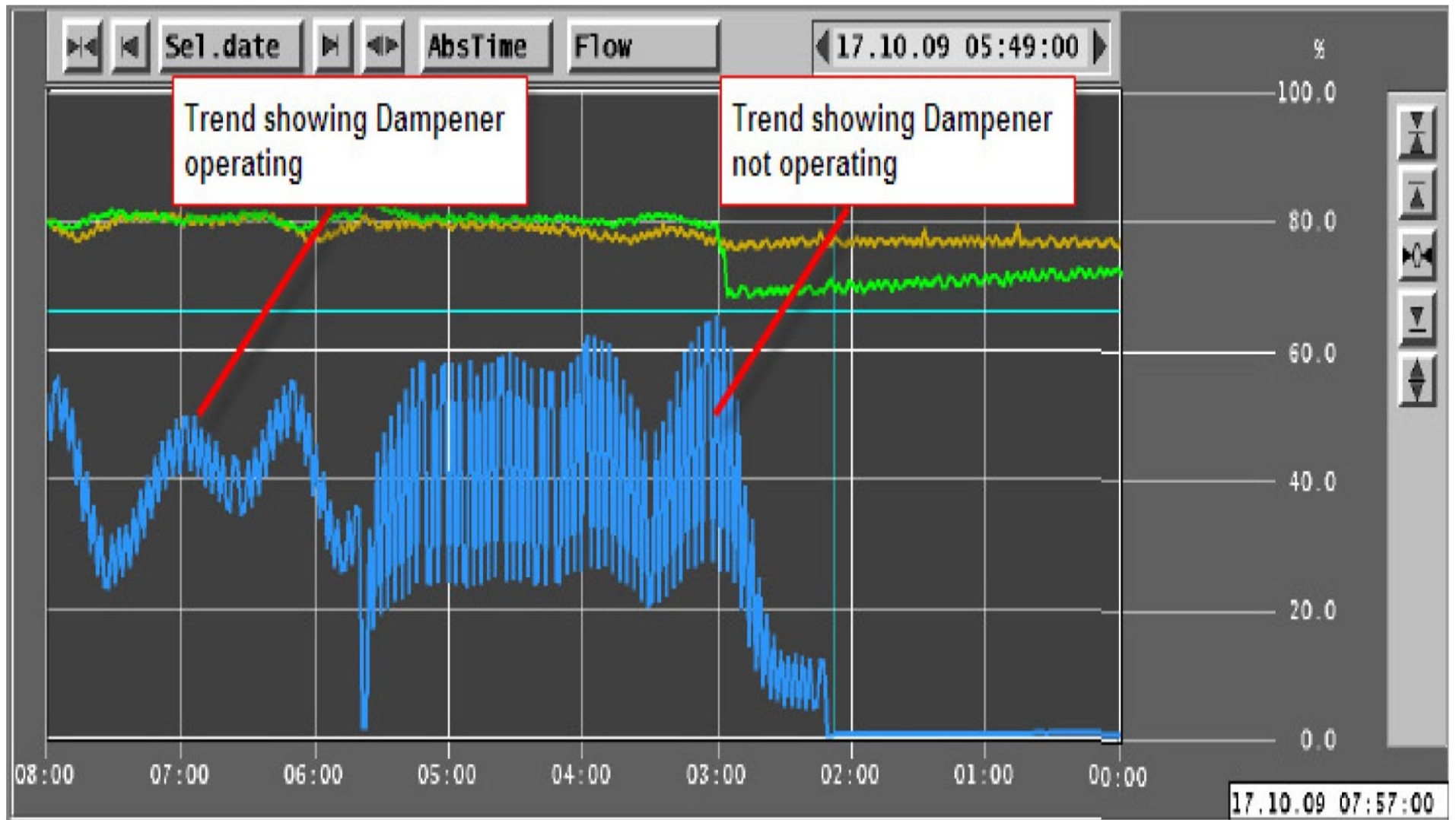

Advantages of the Hydraulic Pressure Damper (HPD)

- **Reliable** dampening solution for hardening material (like cemented paste or slurry)
- **Insensitive towards foreign bodies** like stones
- **Best possible Pulsation Dampening** of hardening material with coarse material size
- **Elimination** of water hammers in the pipeline
- The HPD is working in different pressure levels without any manual adjustment

Important Note:

The VPD- System is only applicable for non-hardening materials

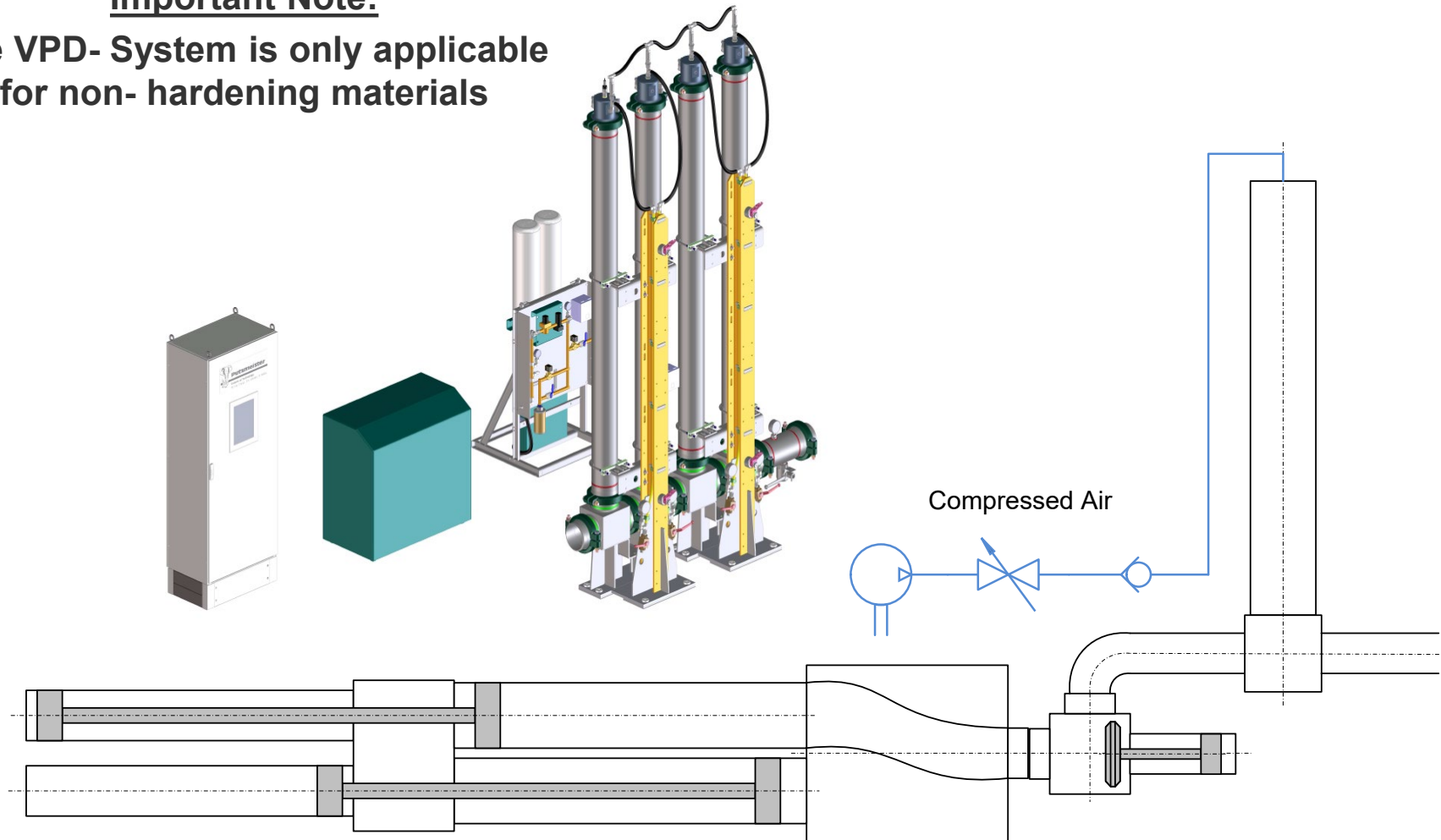



HSP and VPD for Tailings Handling

- Ventilated Pipe Damper (VPD)
 - Idea: Compressed air used as a spring
 - No wear parts (membrane)
 - No permanent loss of energy
 - Required materials:
 - Compressor, pipe dampers, level sensors, valves

Ventilated Pipe Damper (VPD) test setup

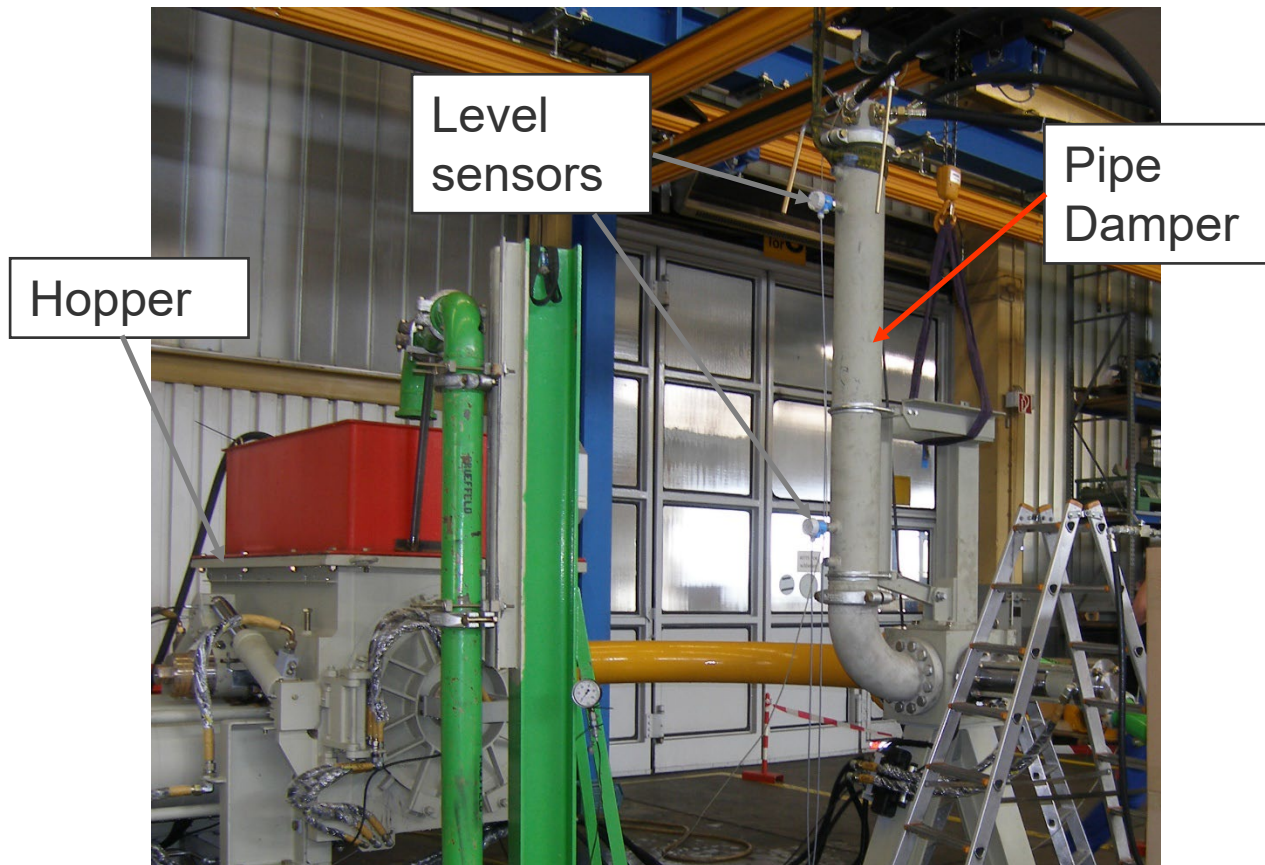

Ventilated Pipe Damper (VPD) pressure curves

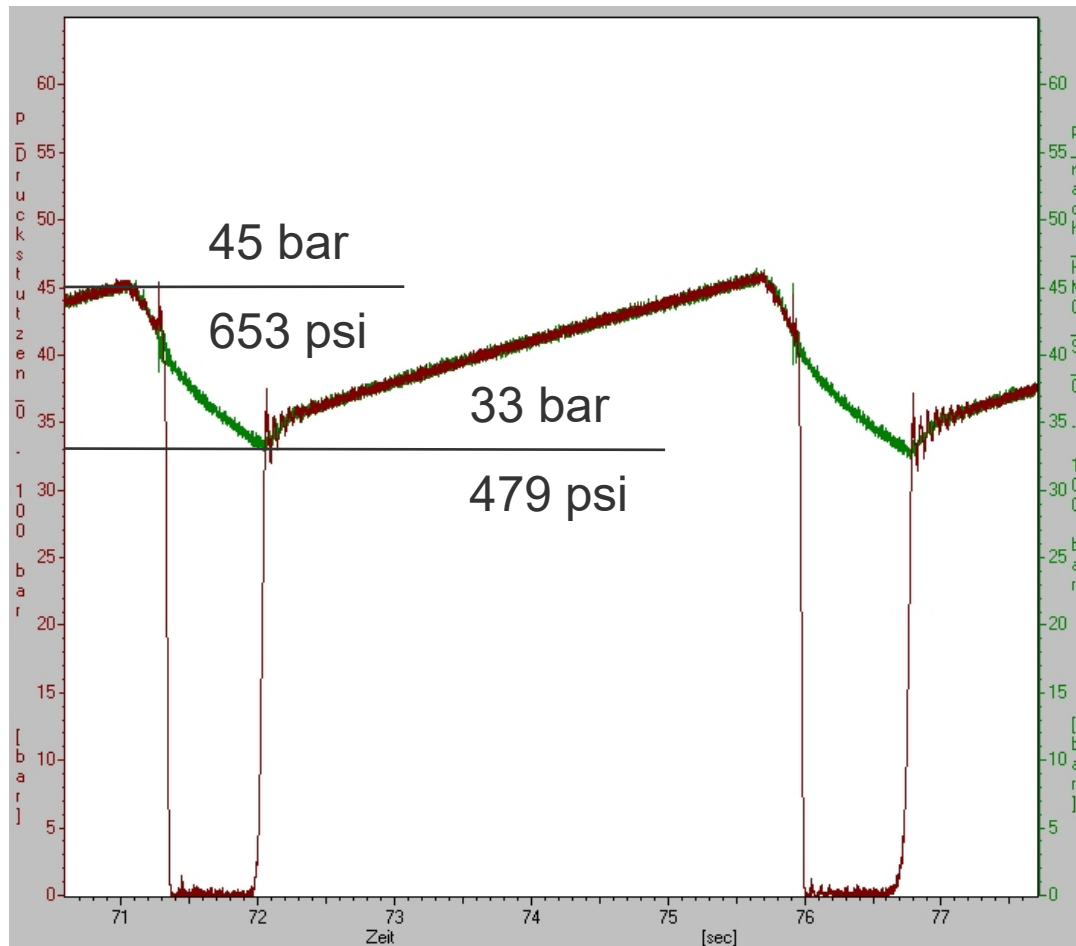

Drop of pressure:
26%

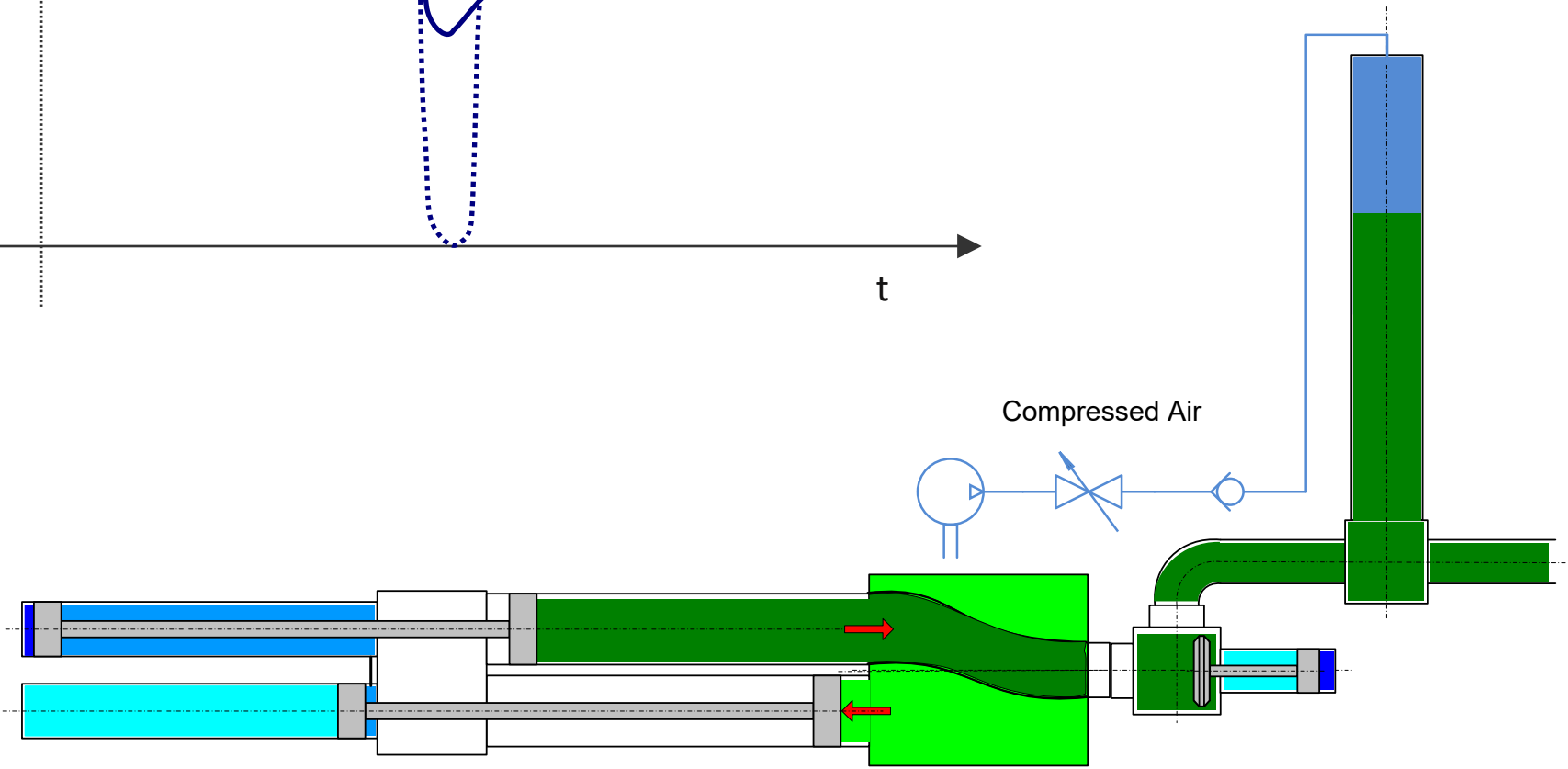
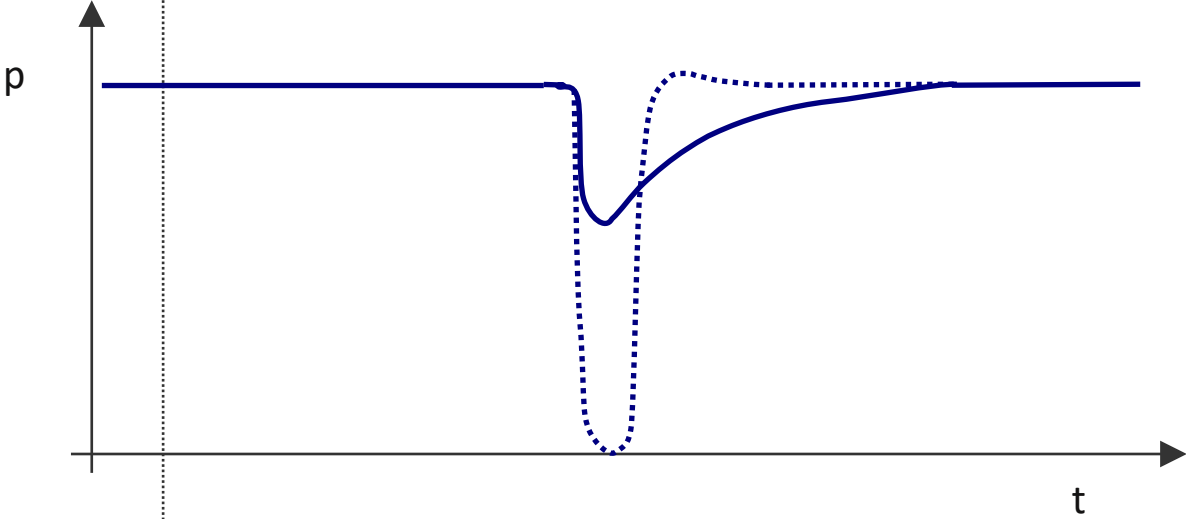

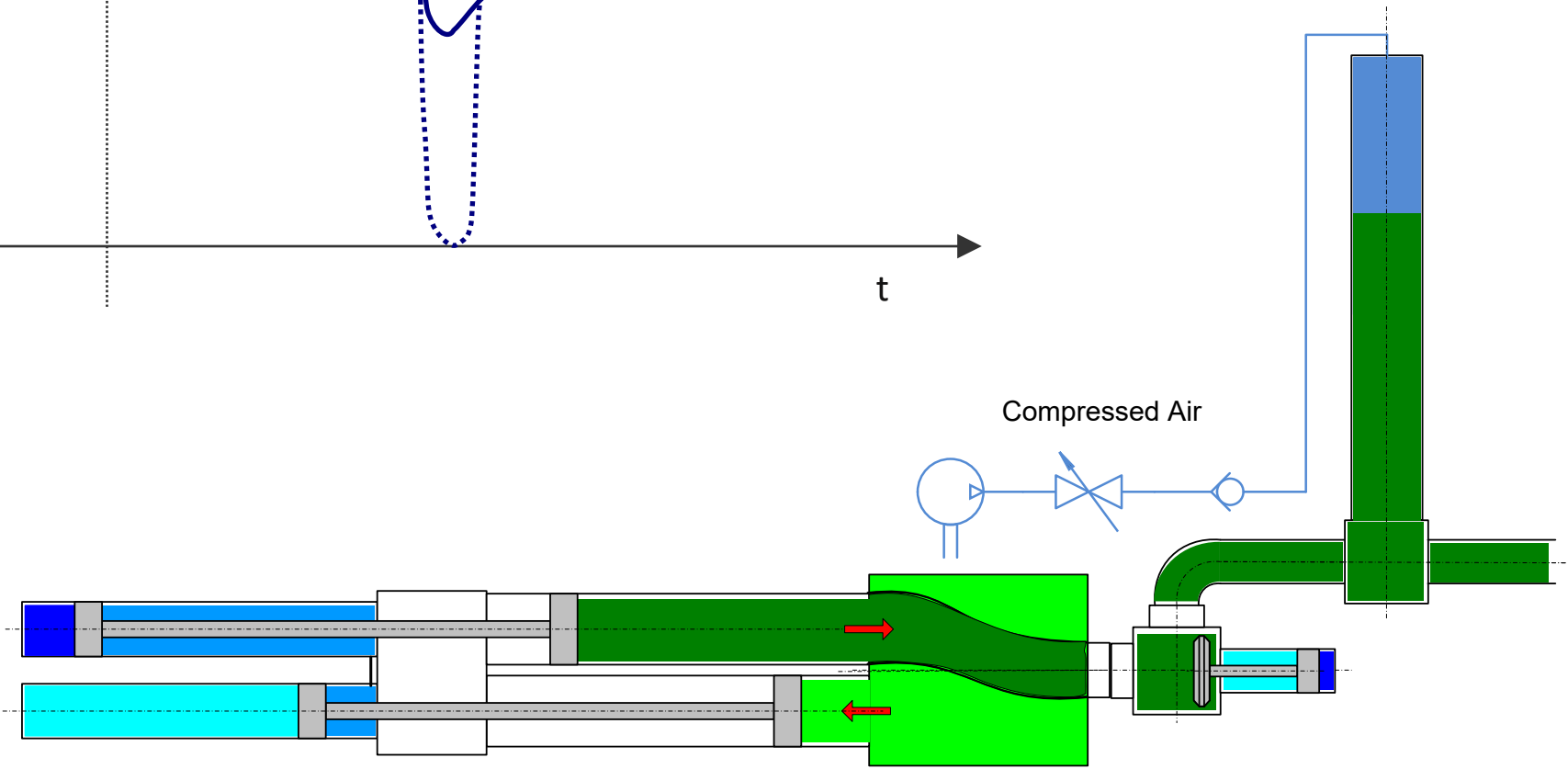
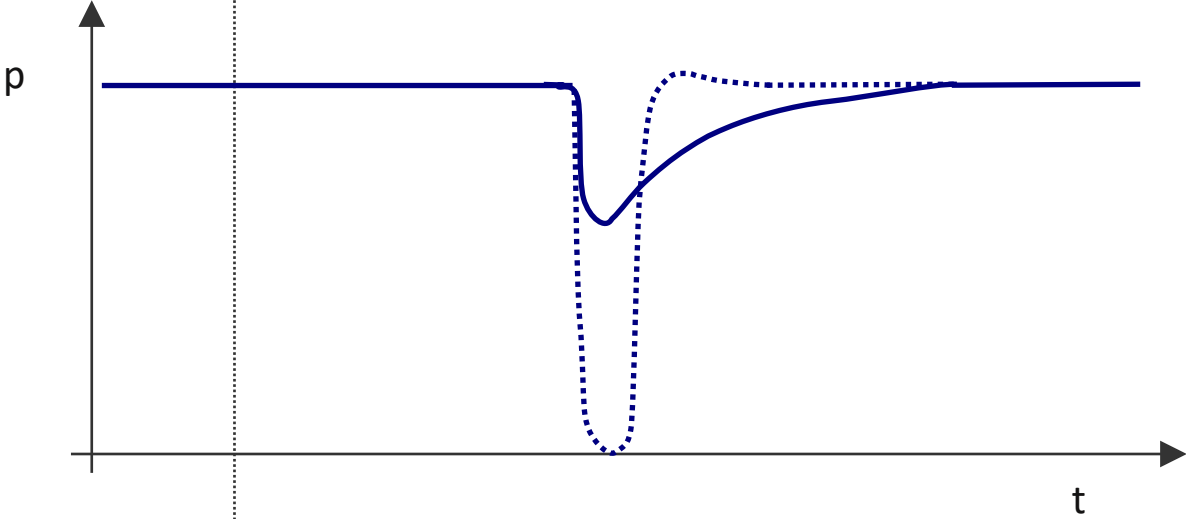

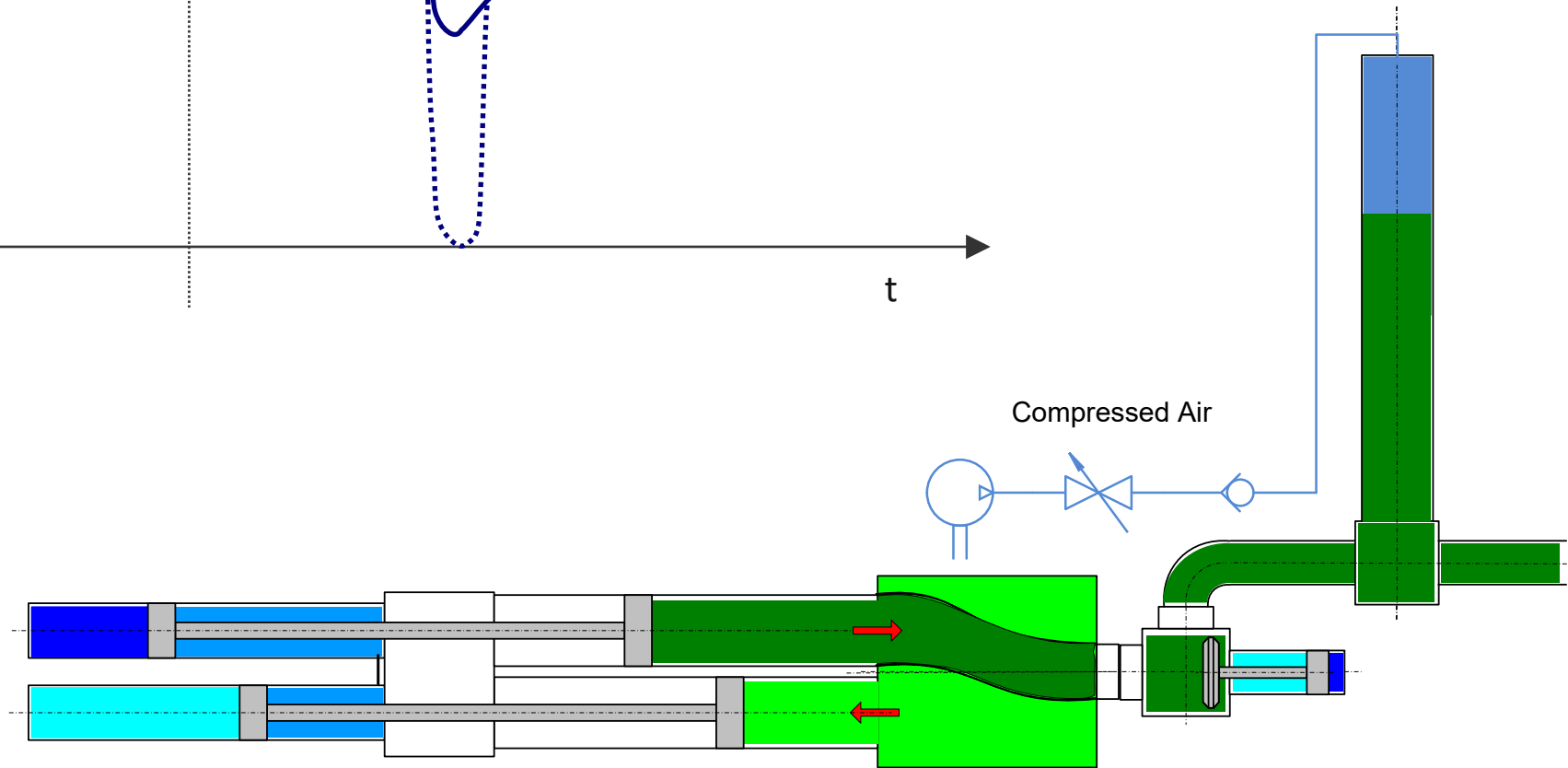
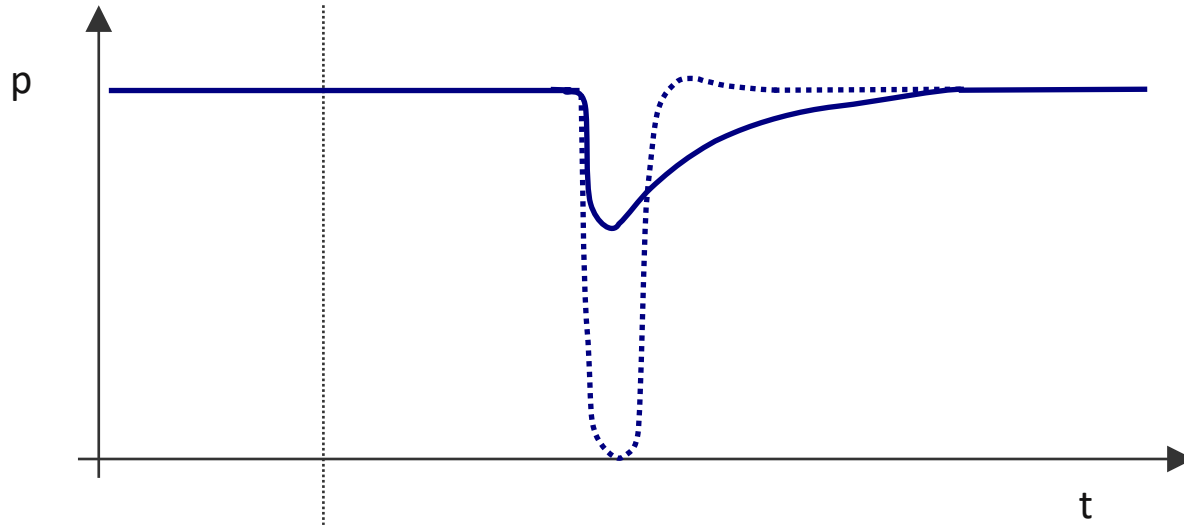

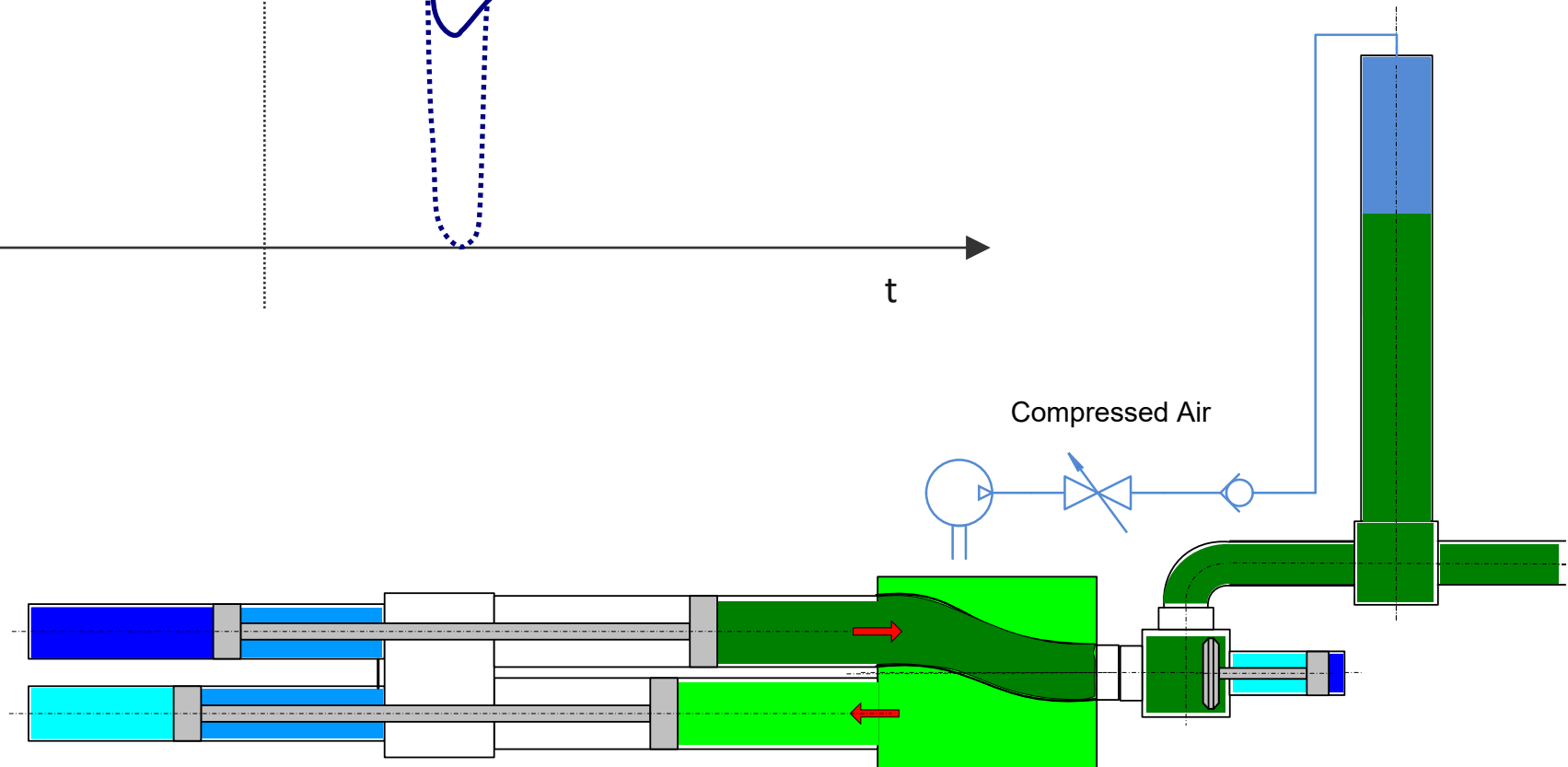
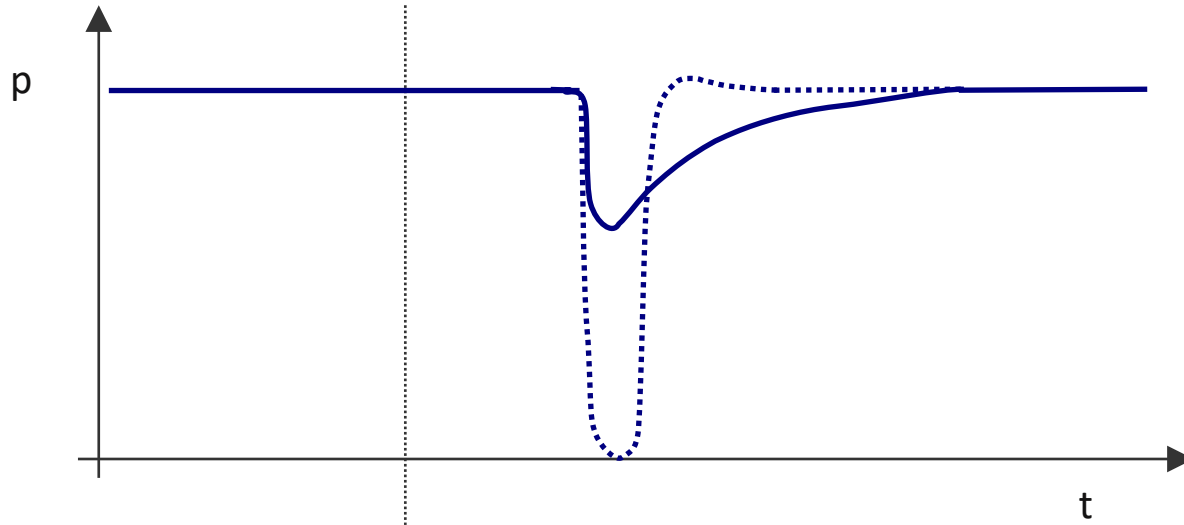

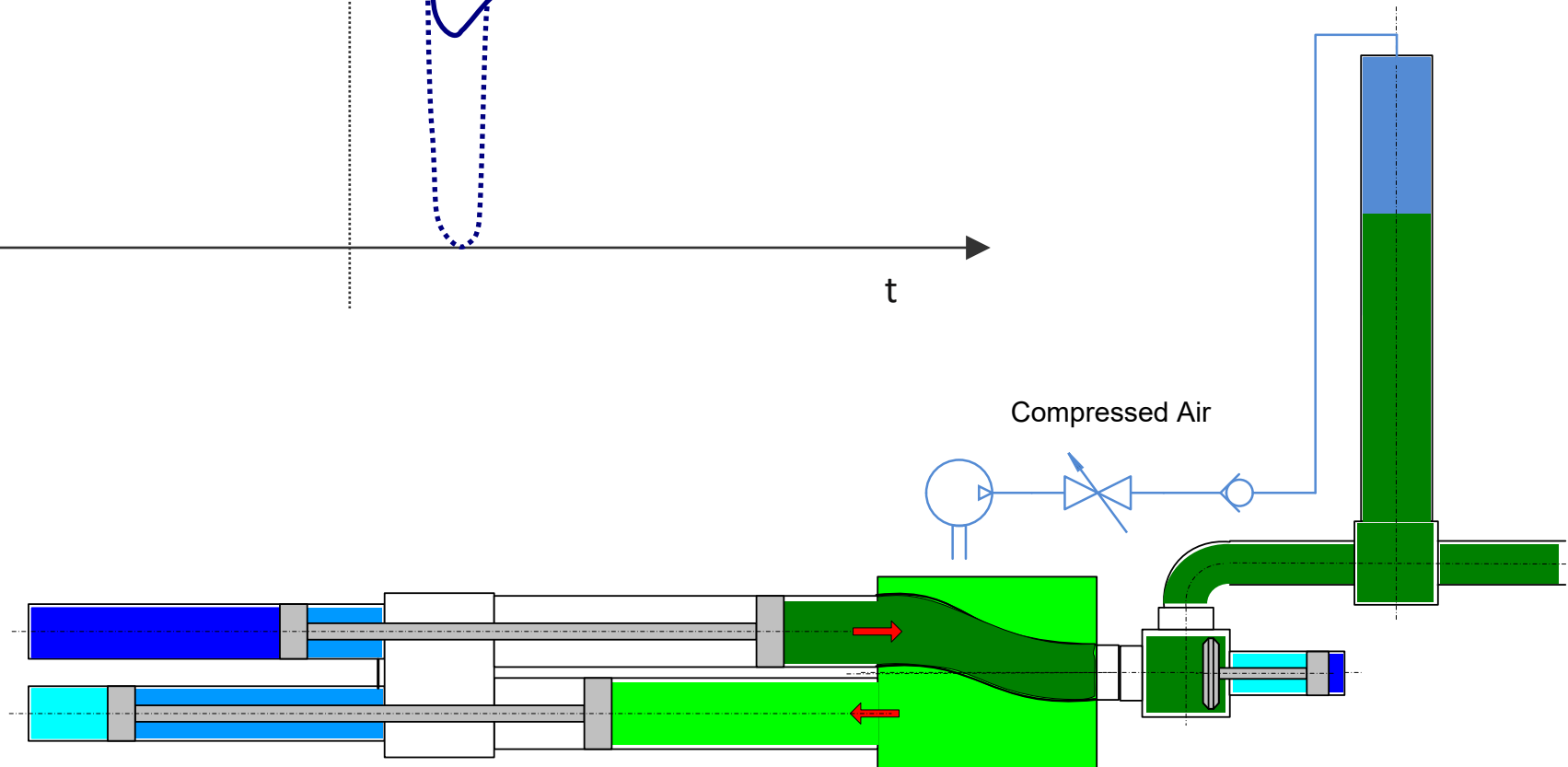
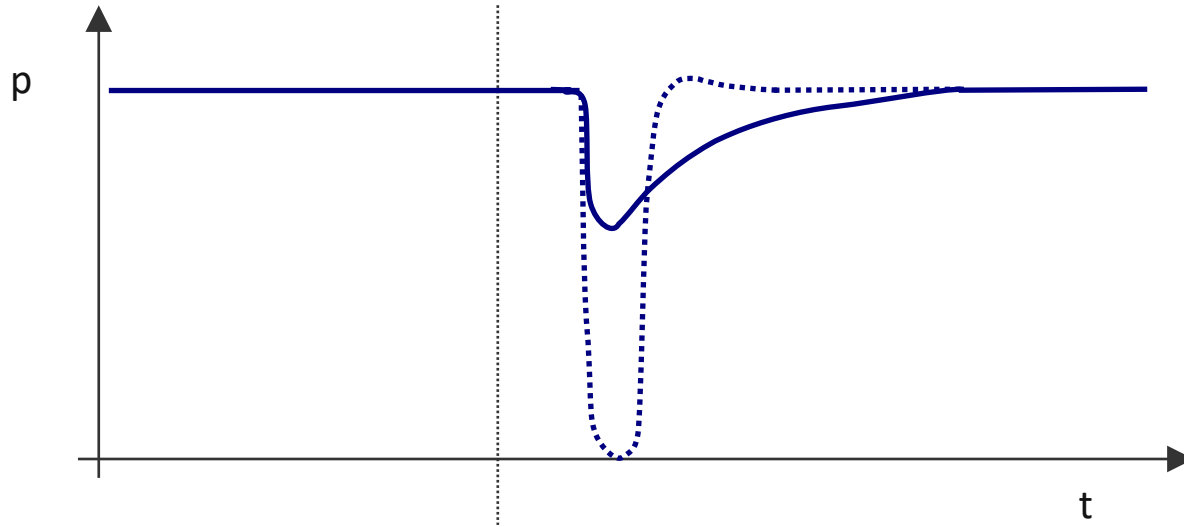

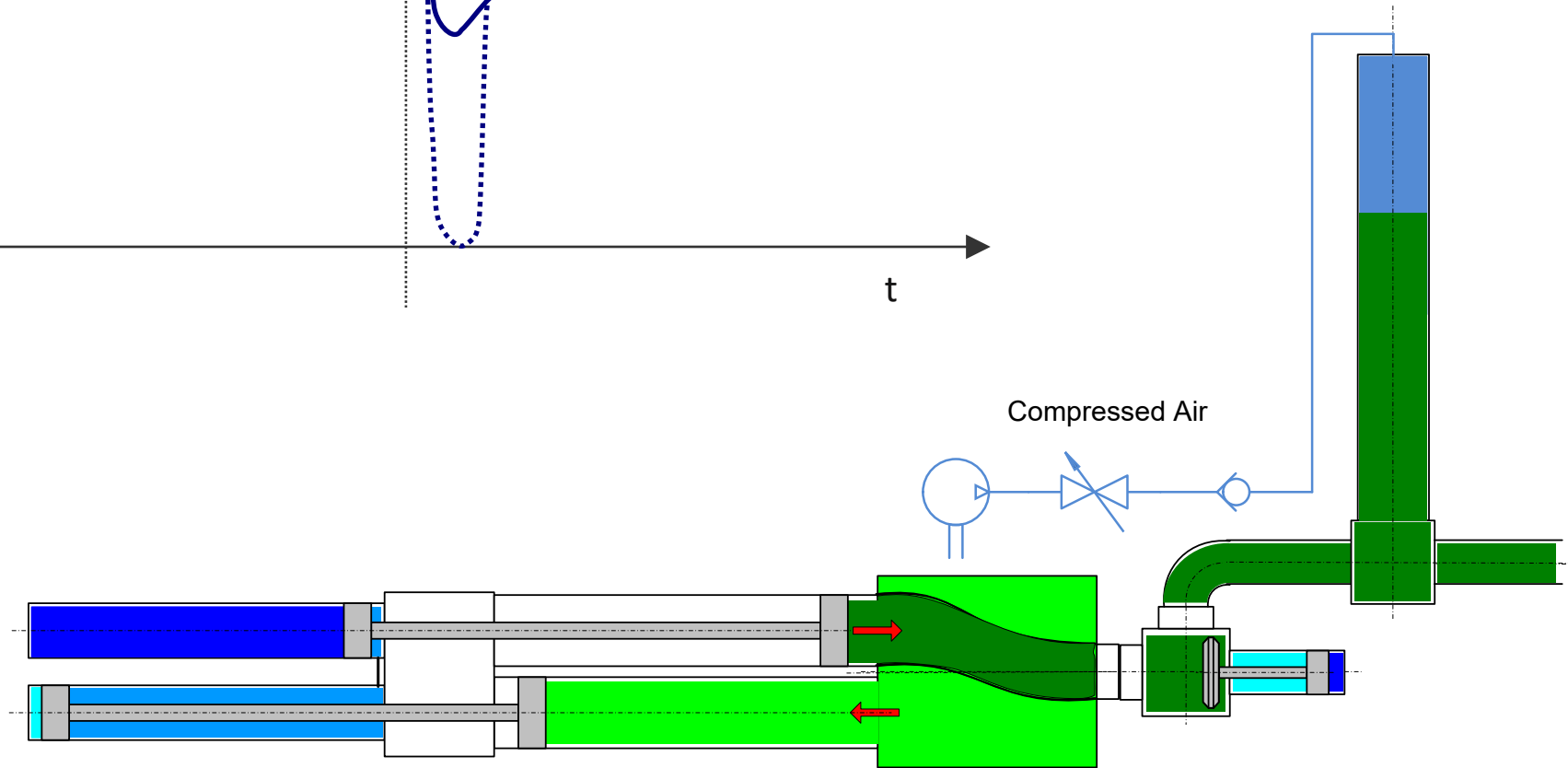
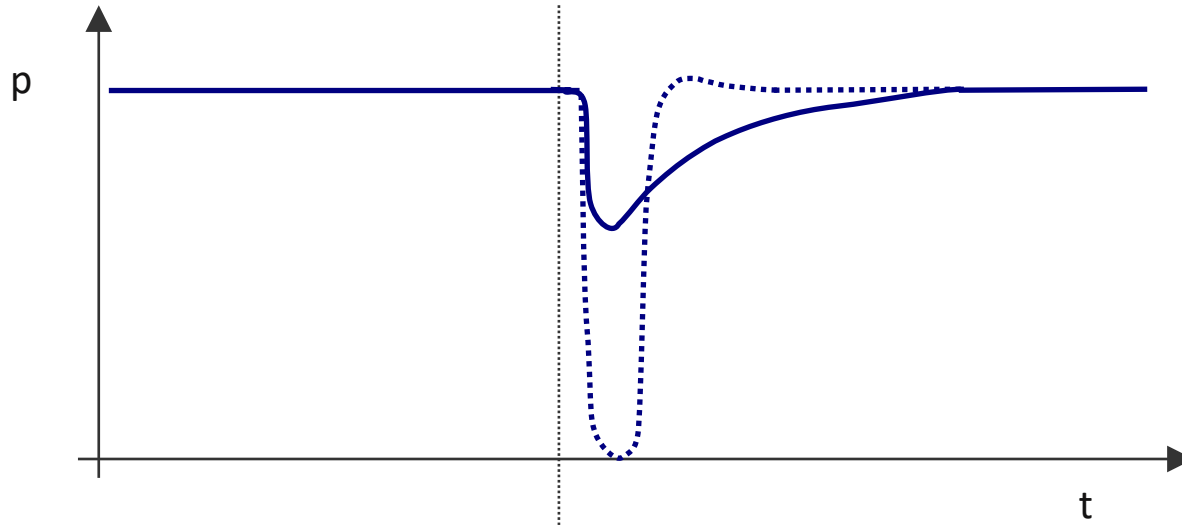

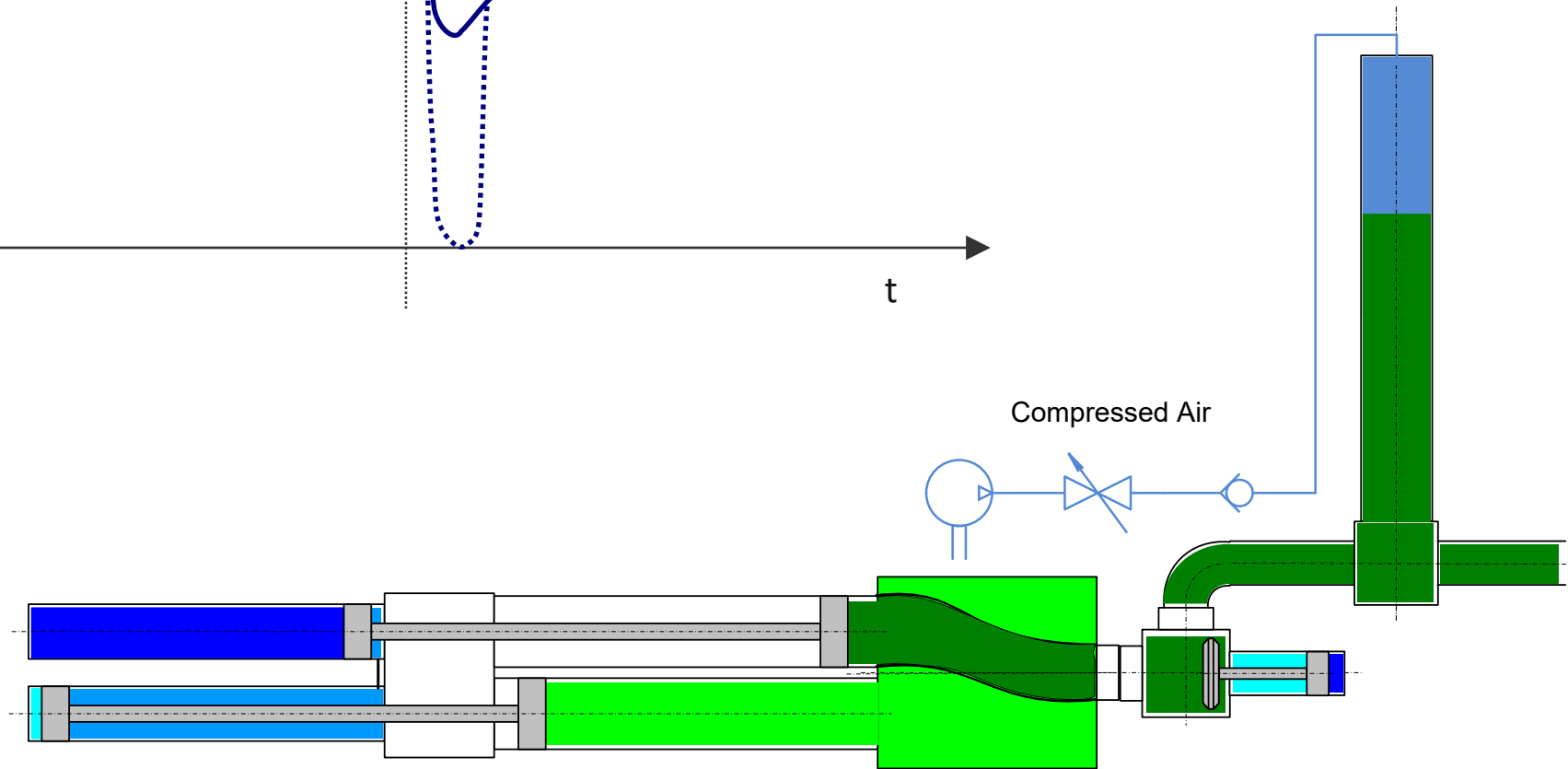
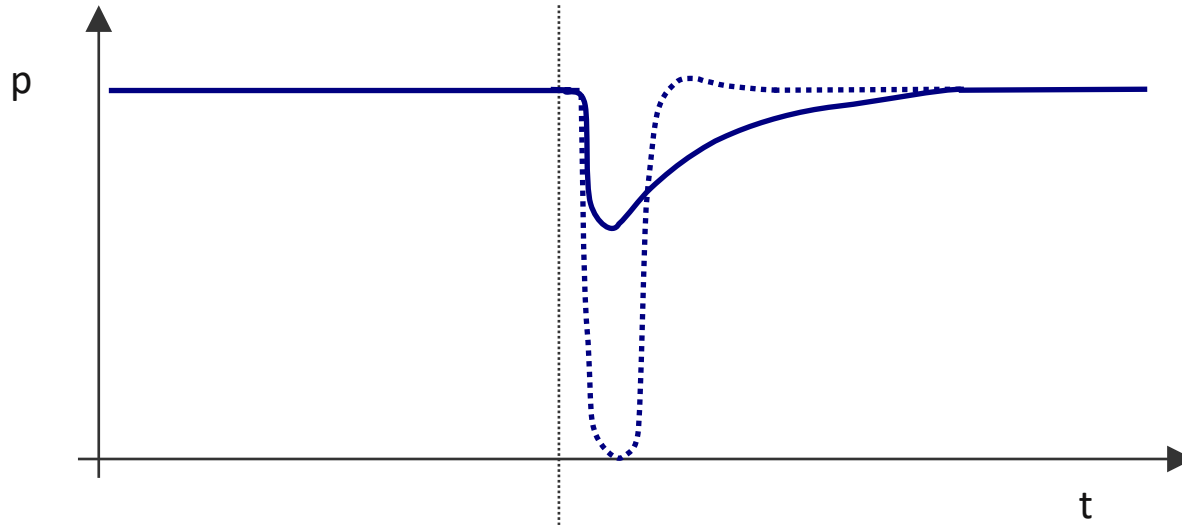

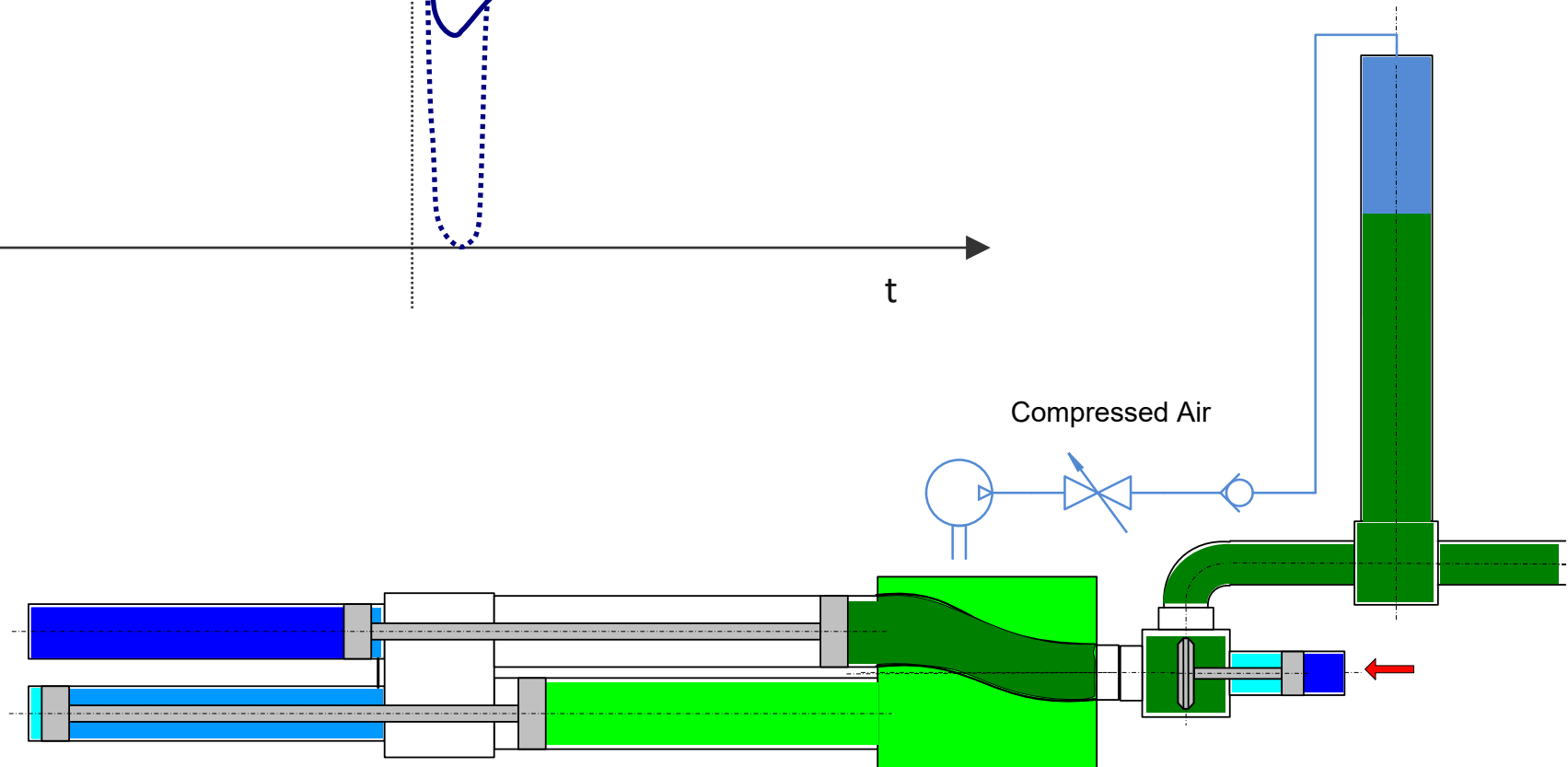
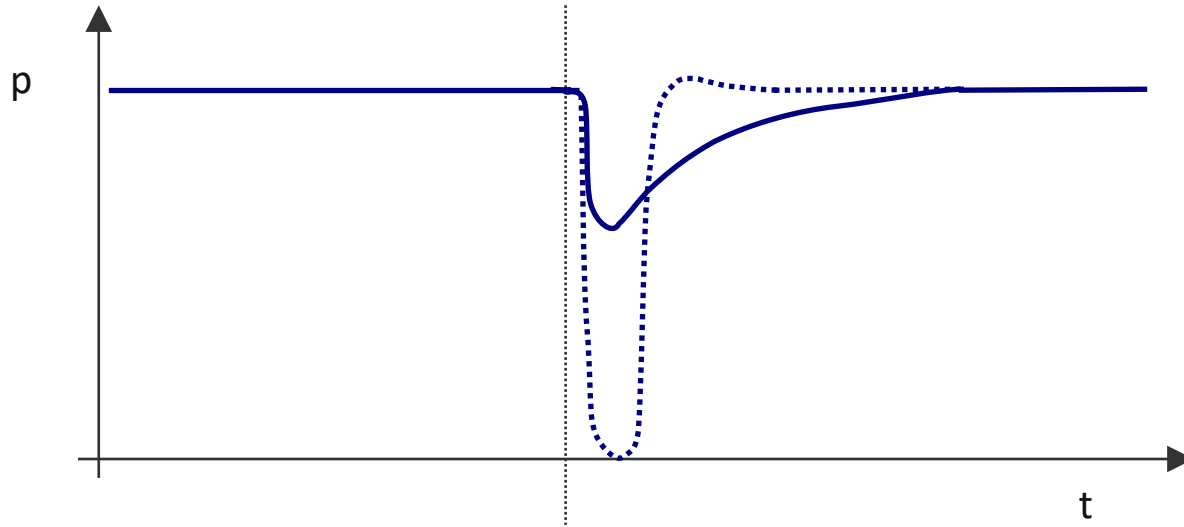

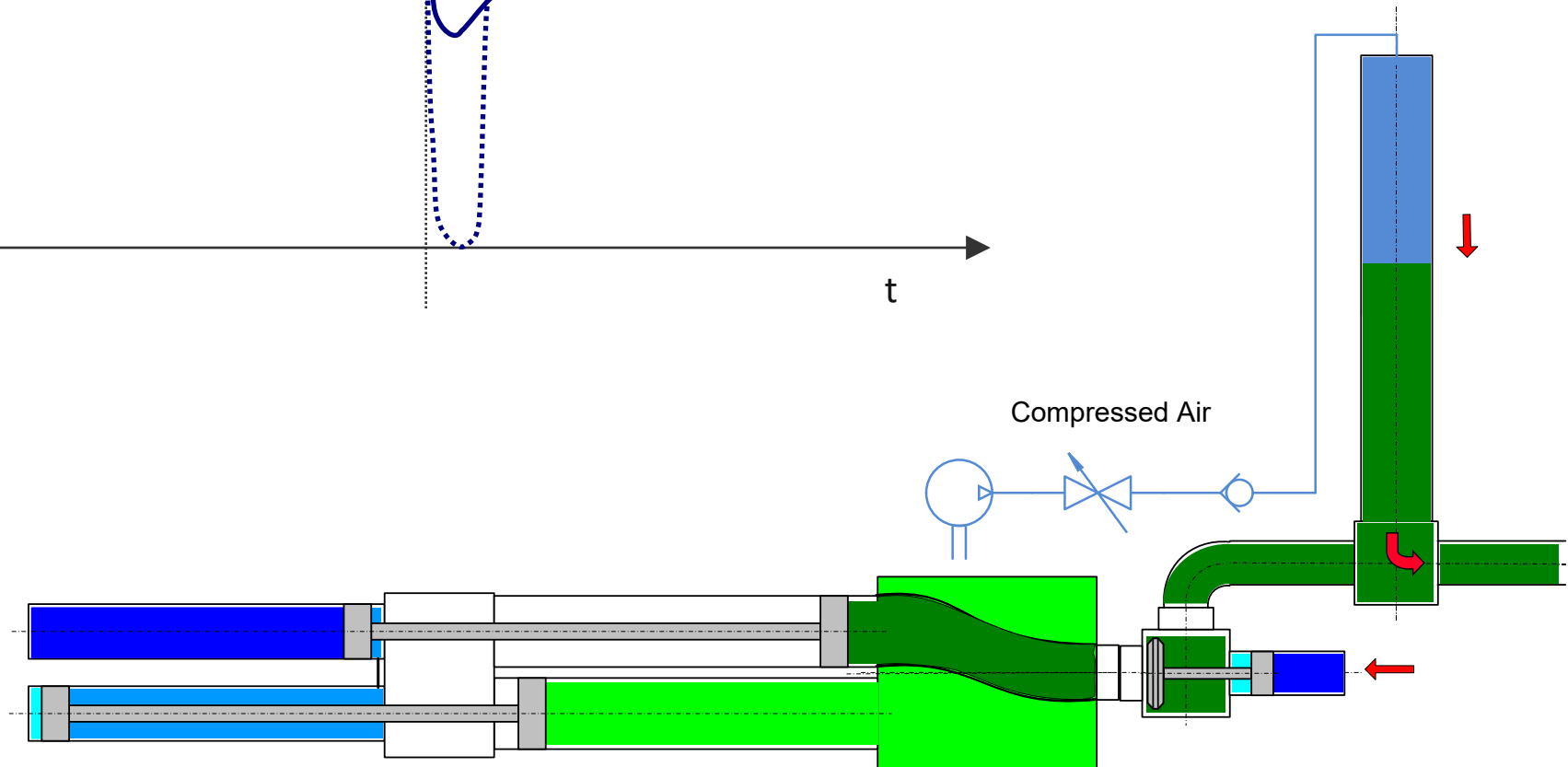
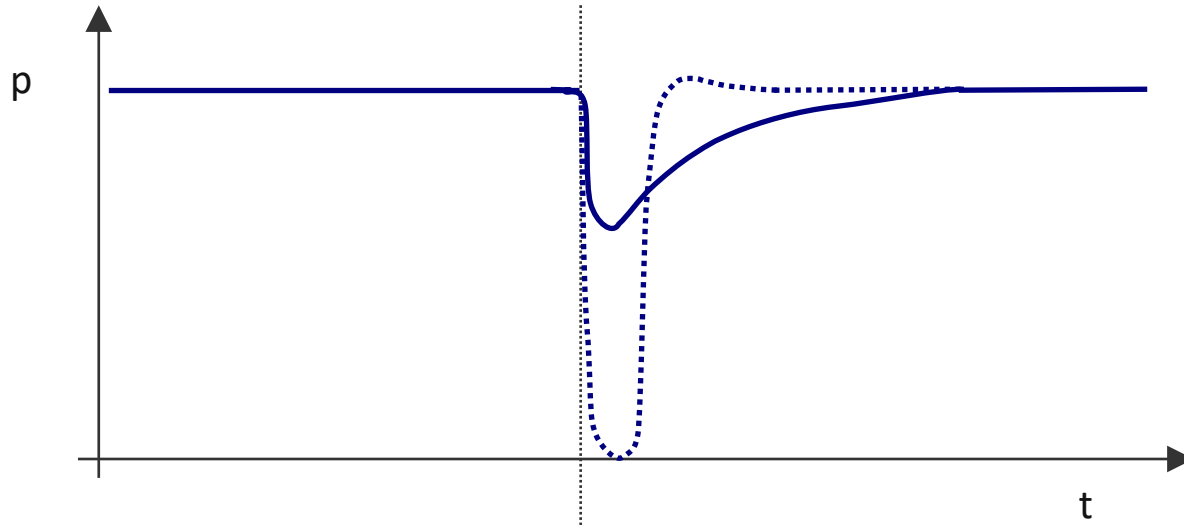

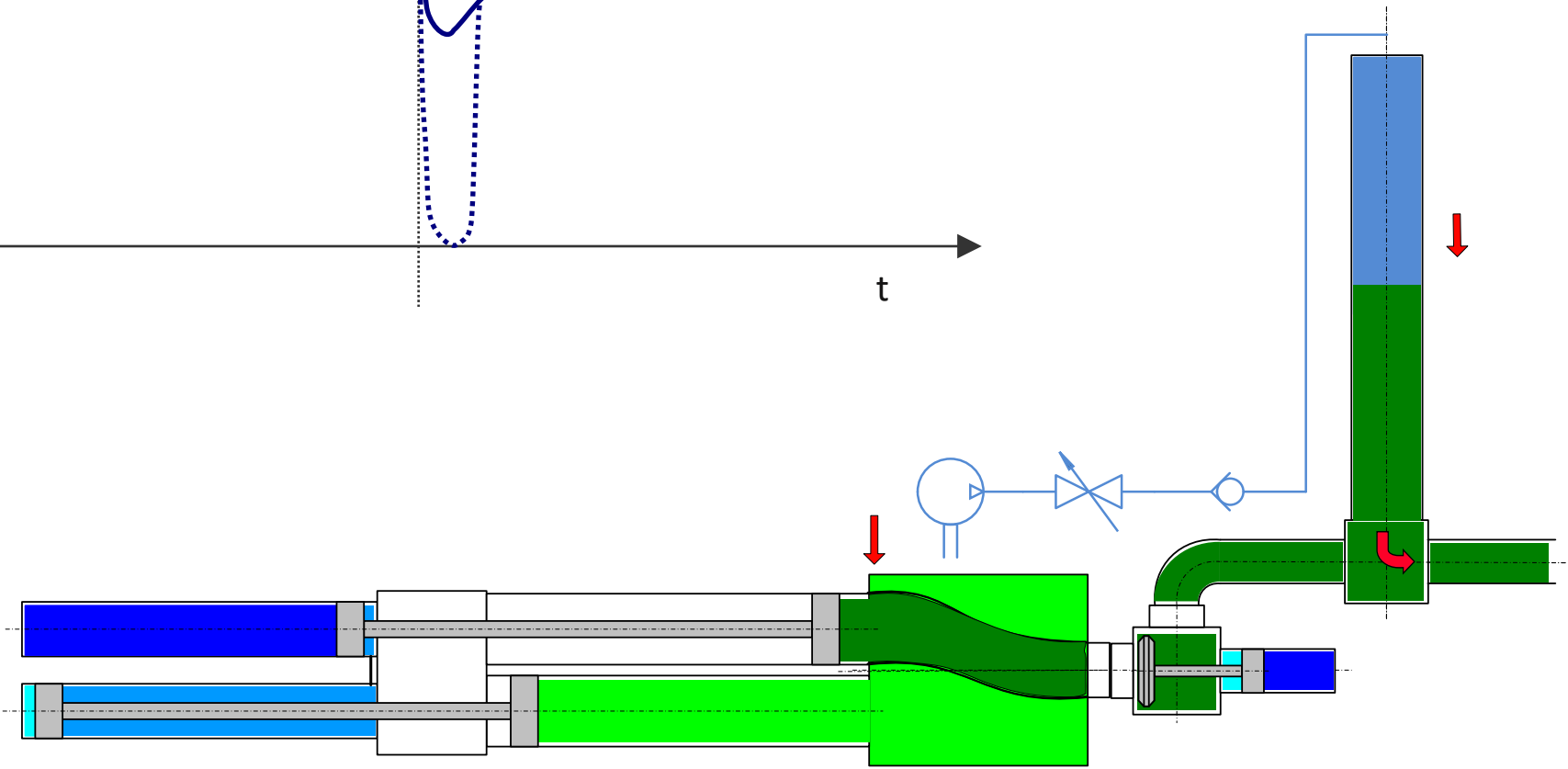
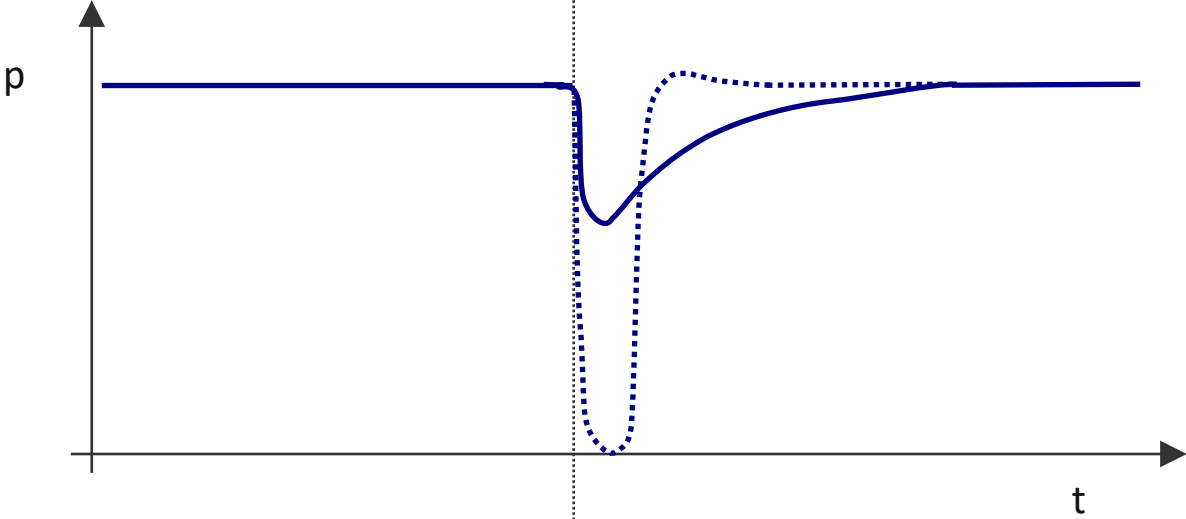

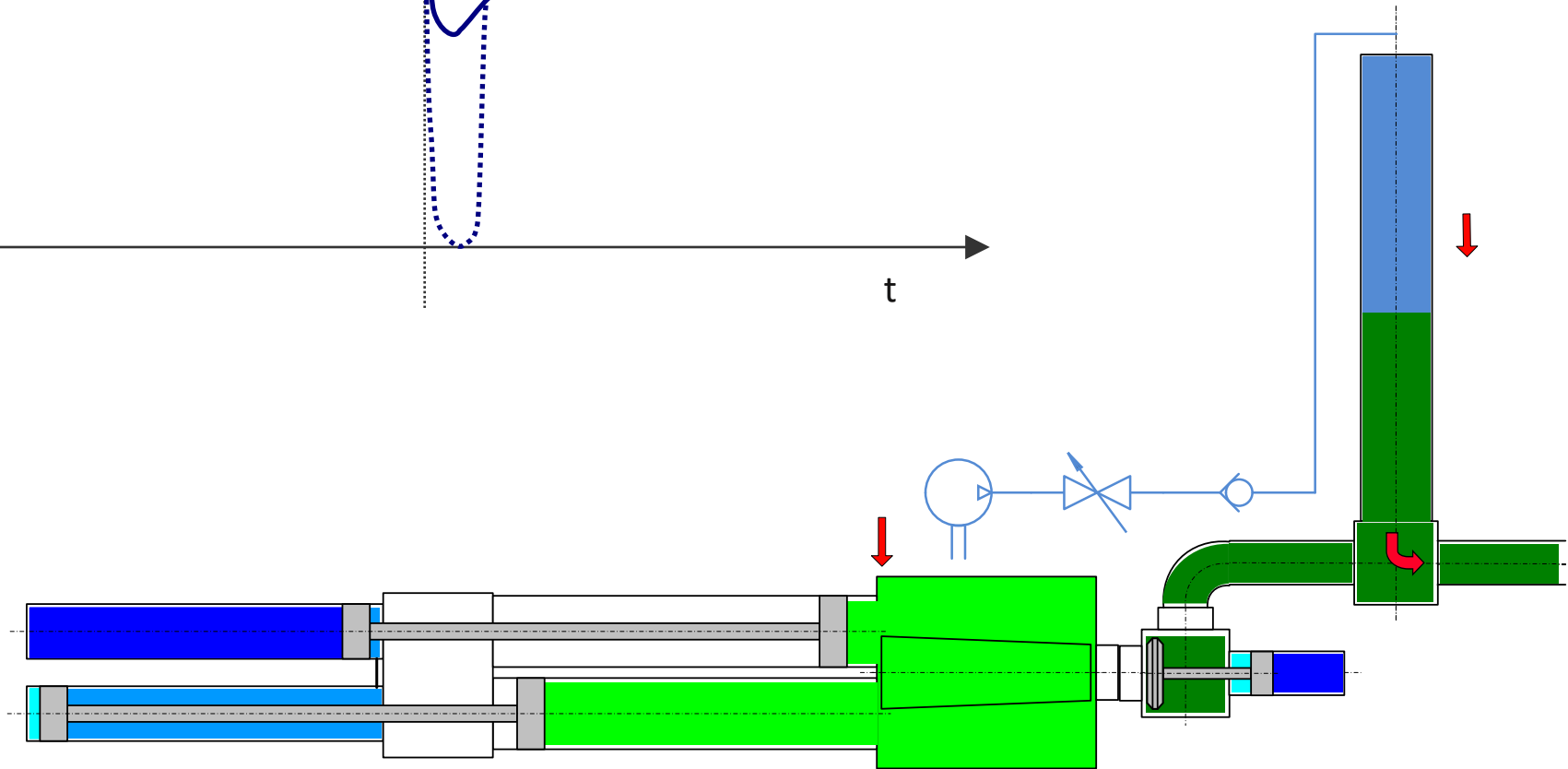
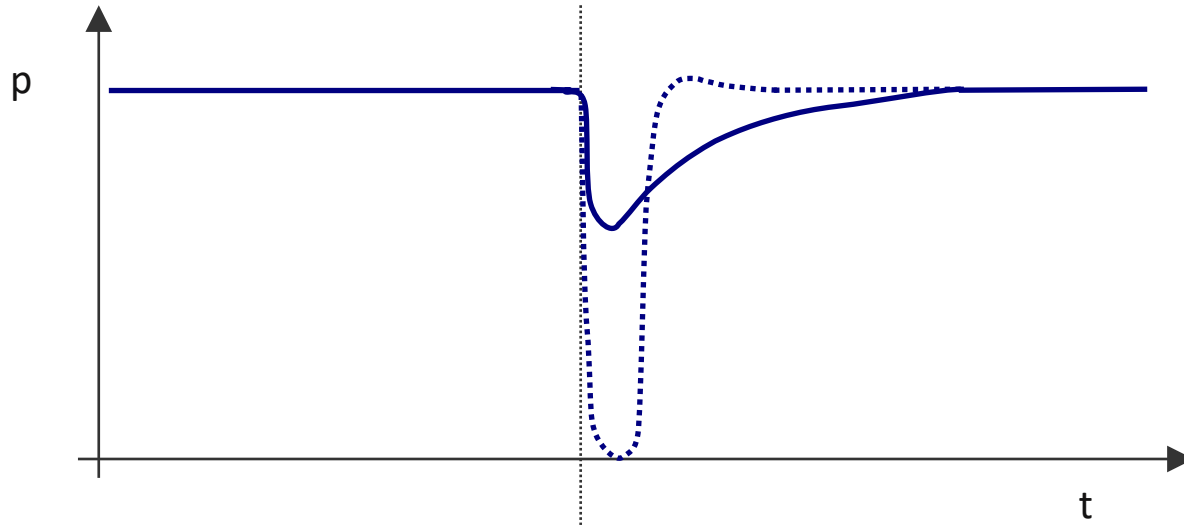

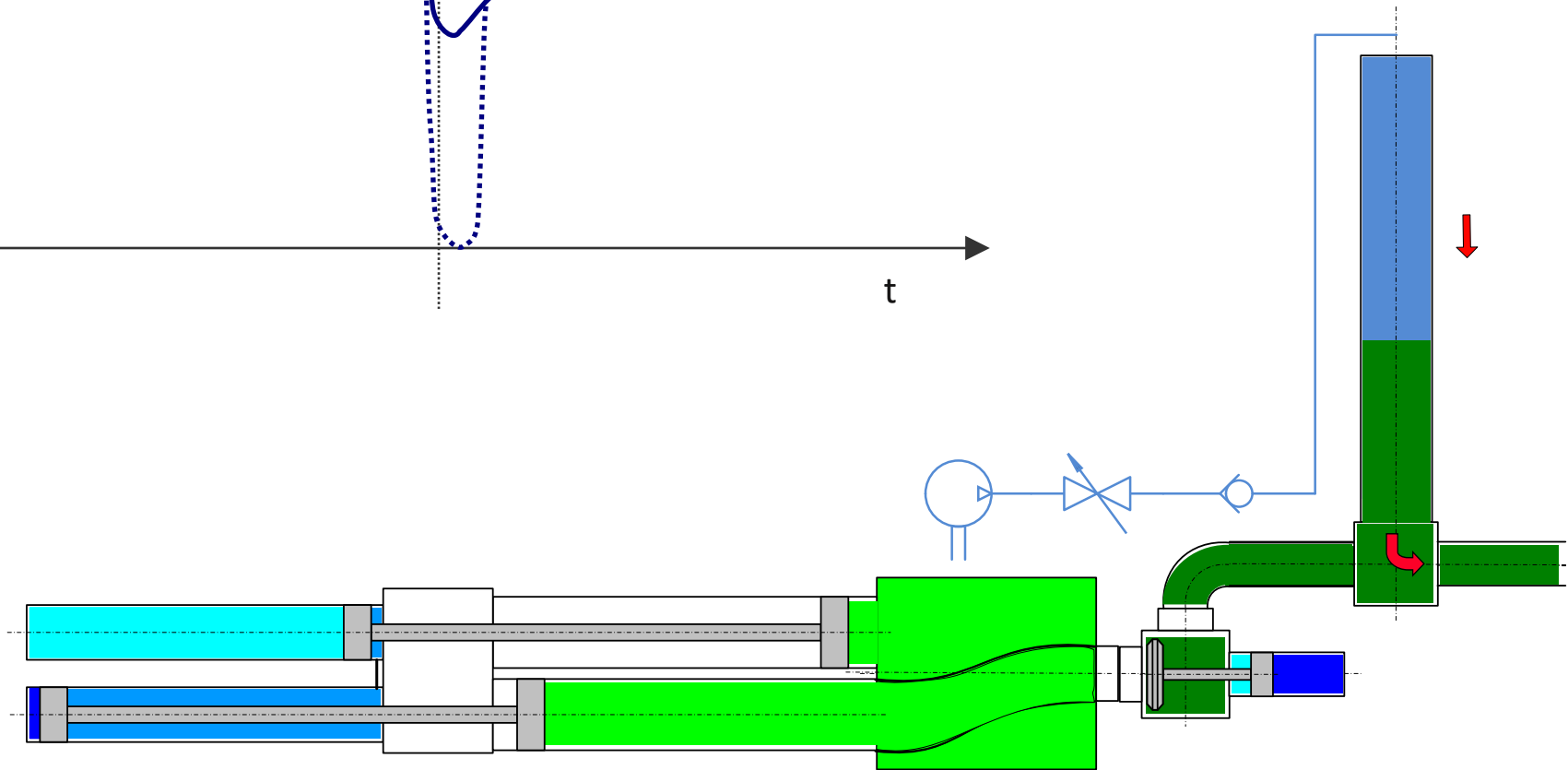
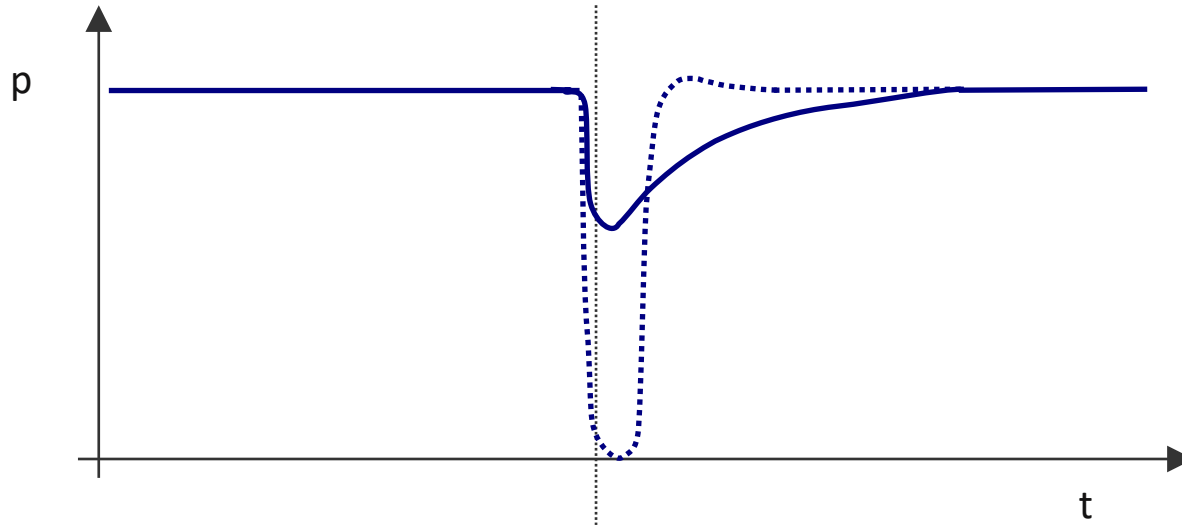

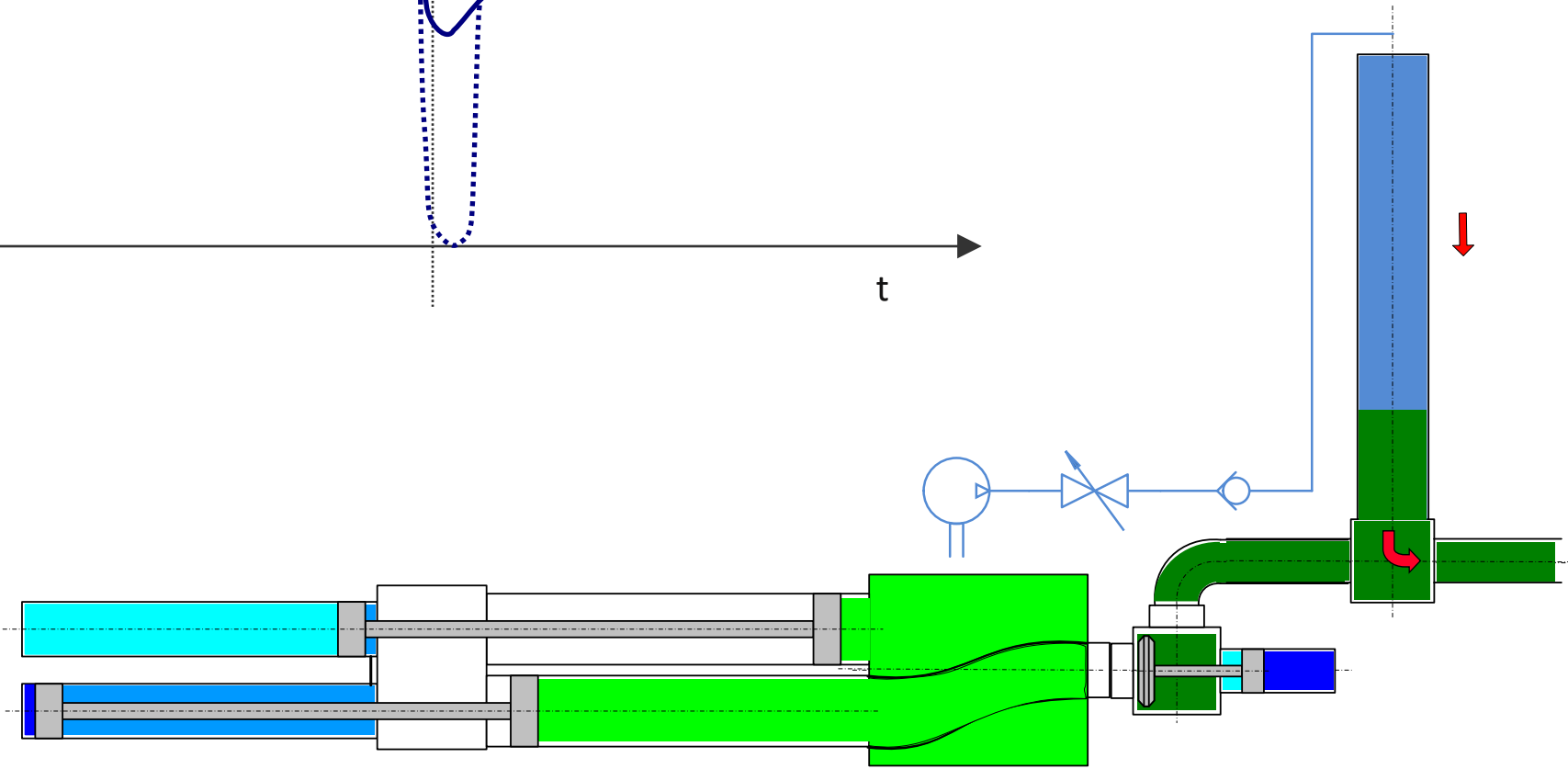
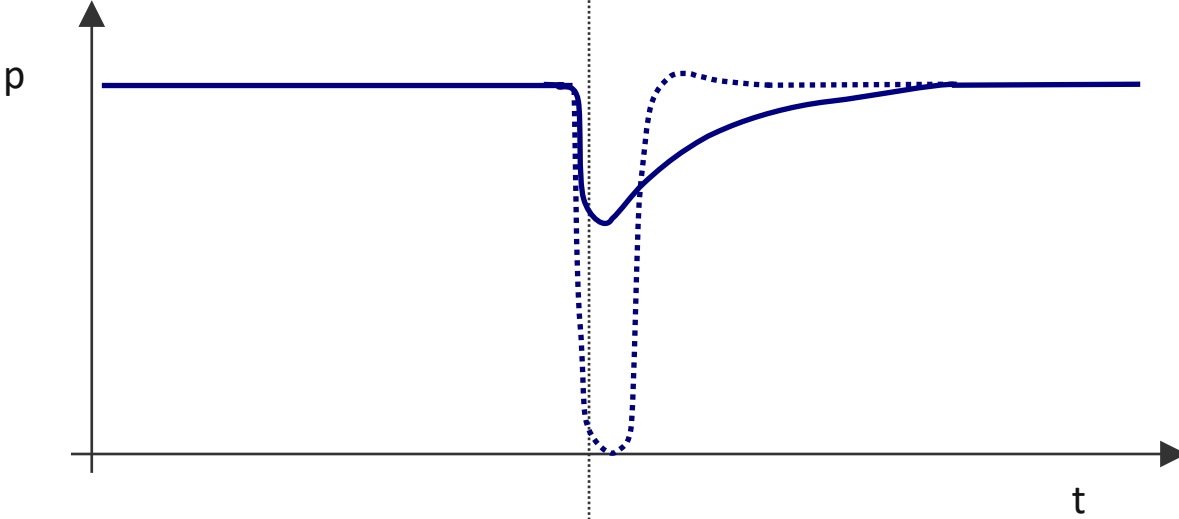

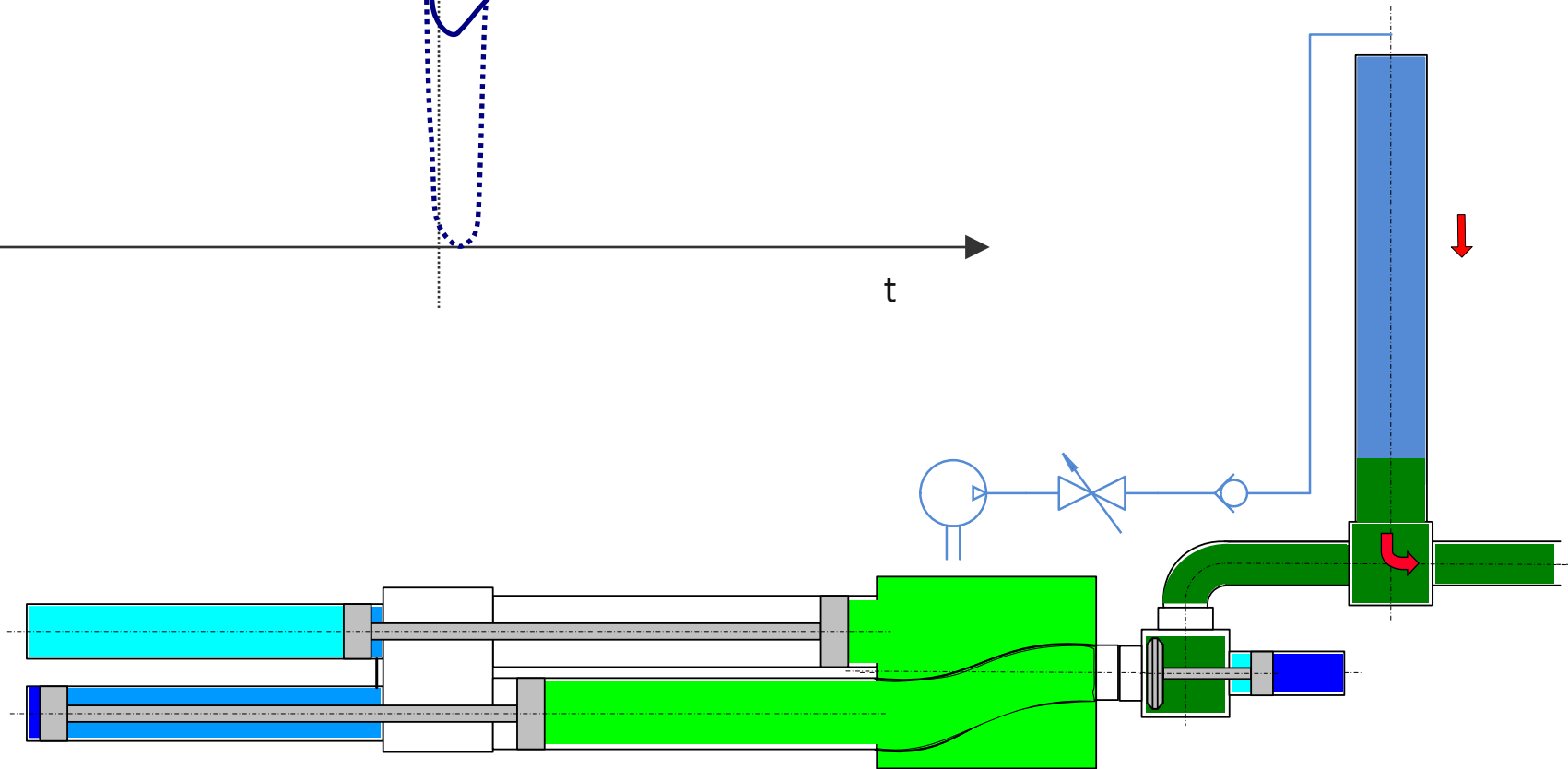
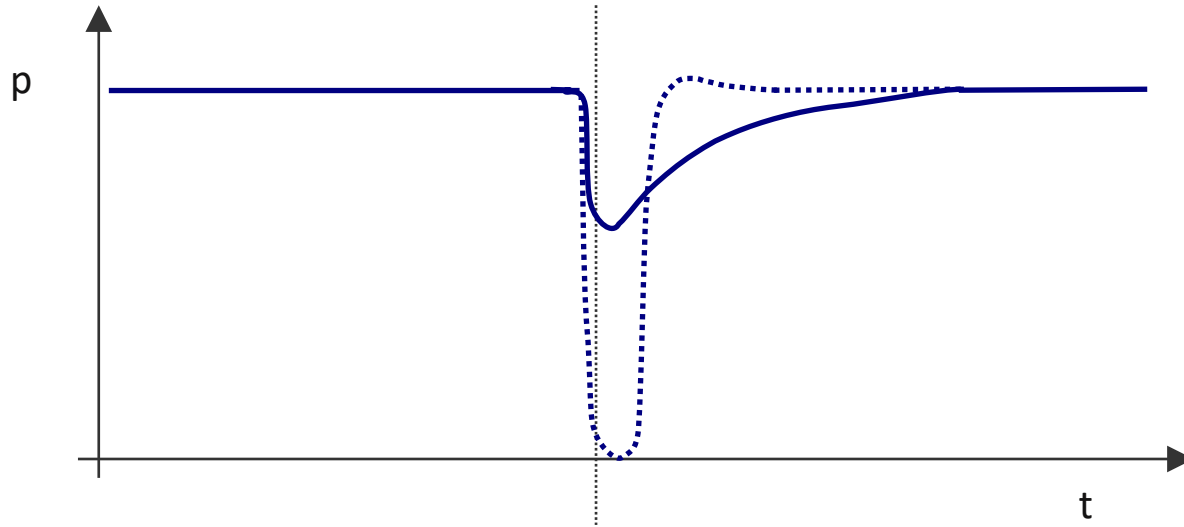

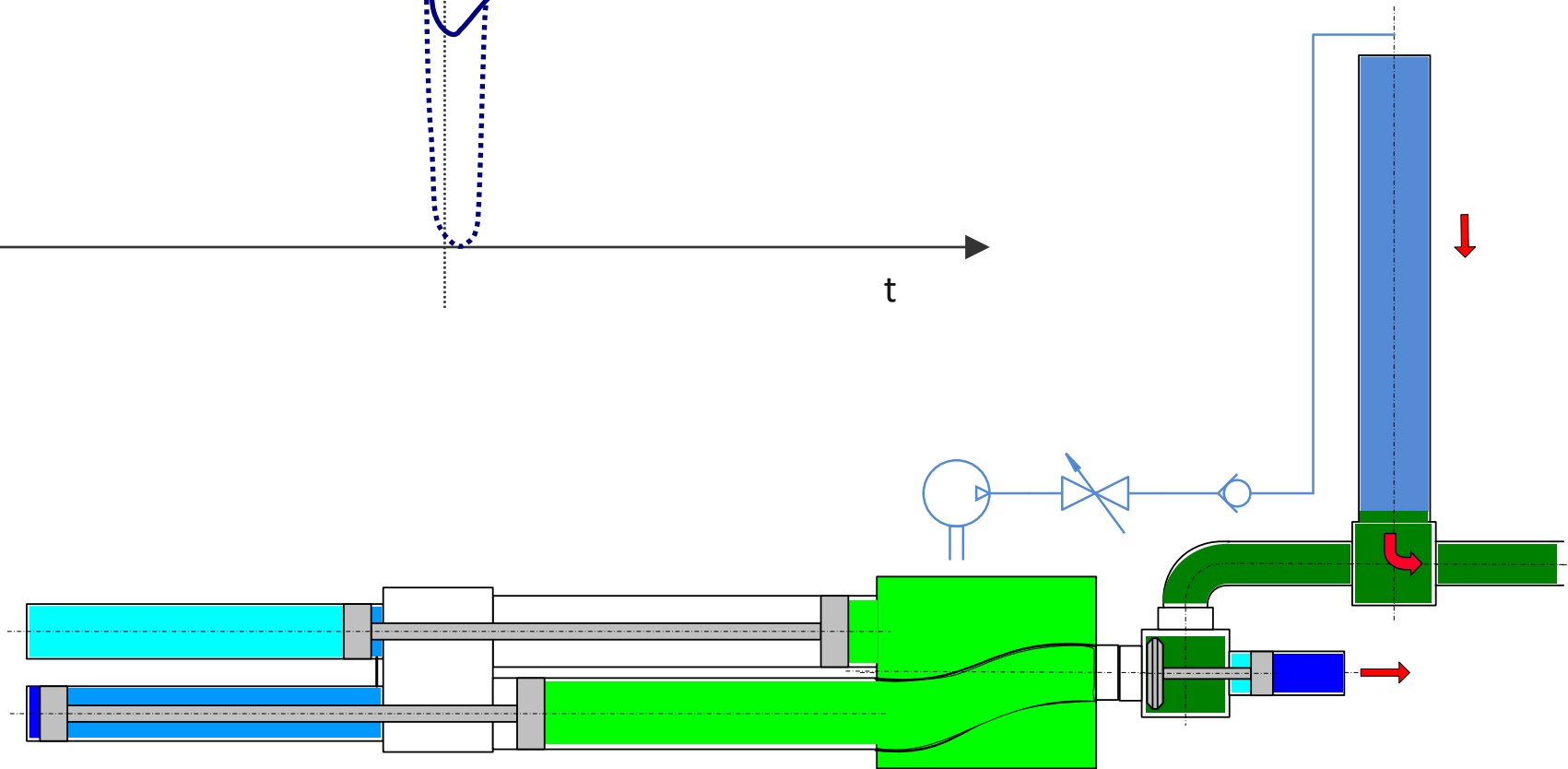
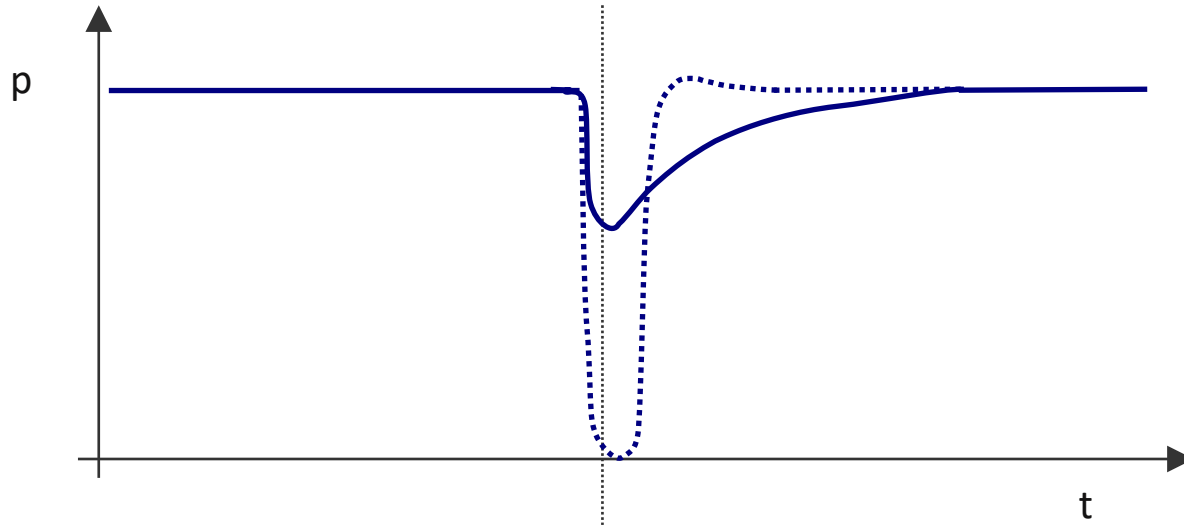

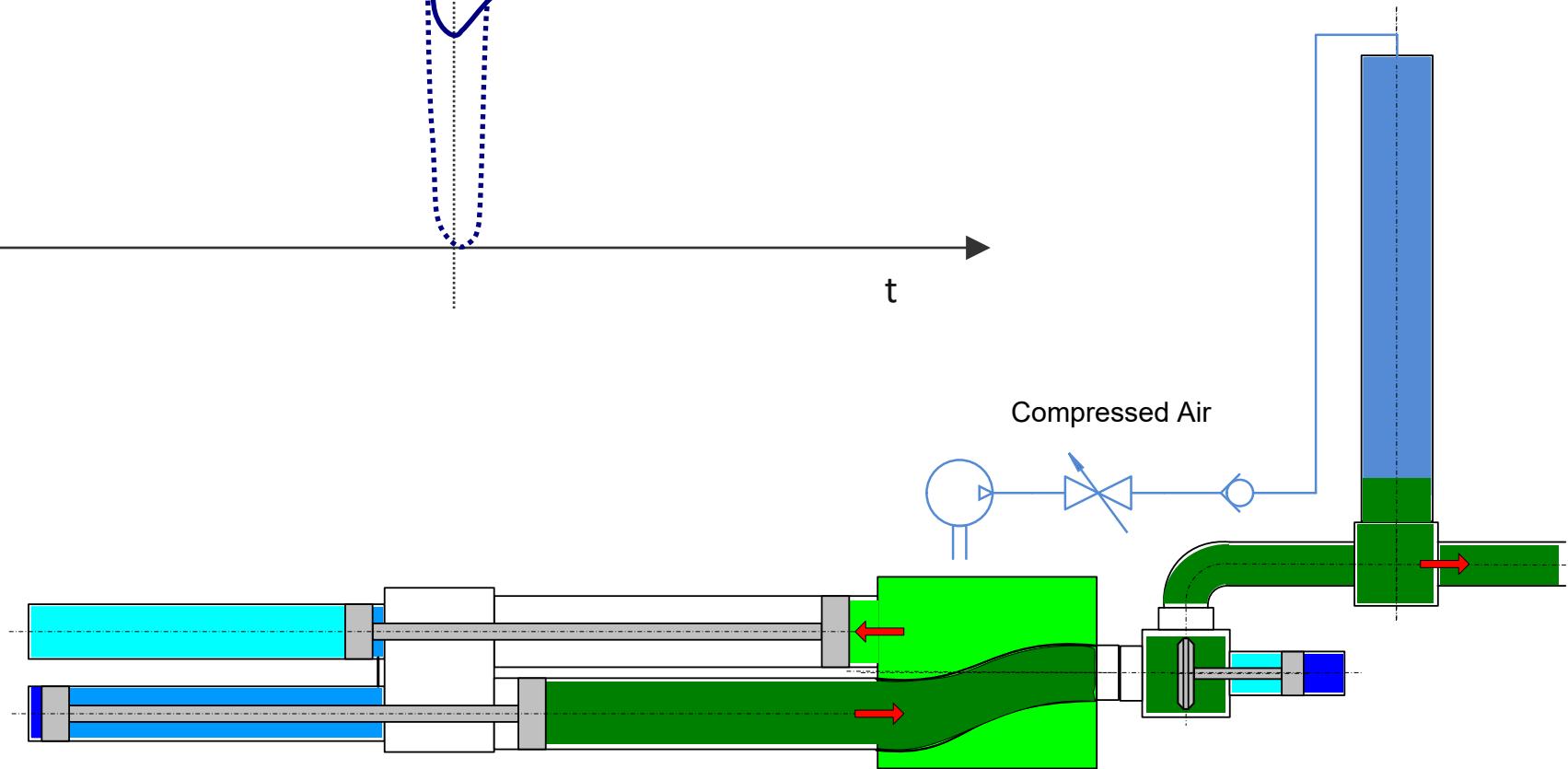
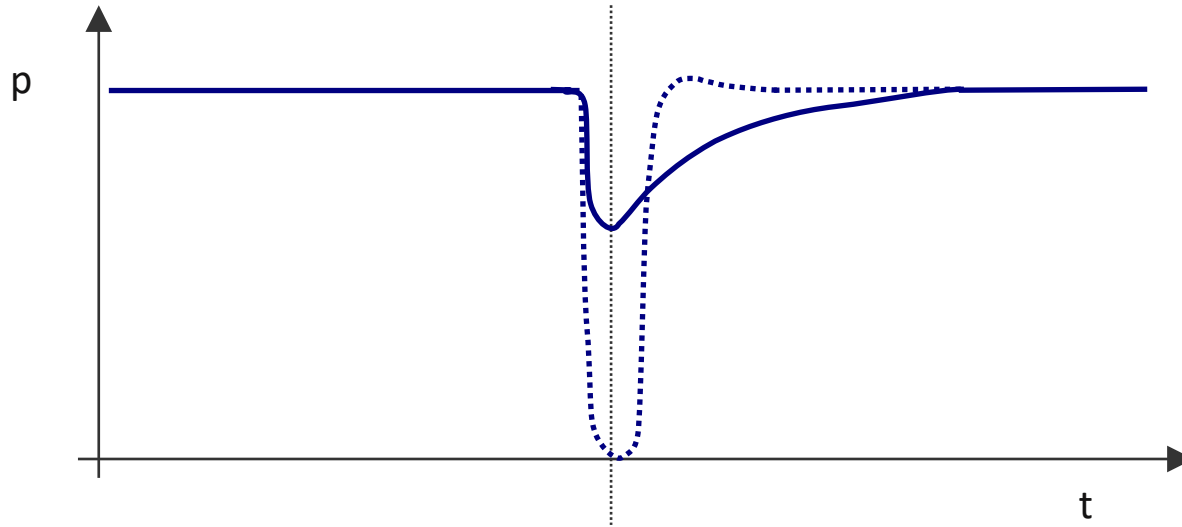

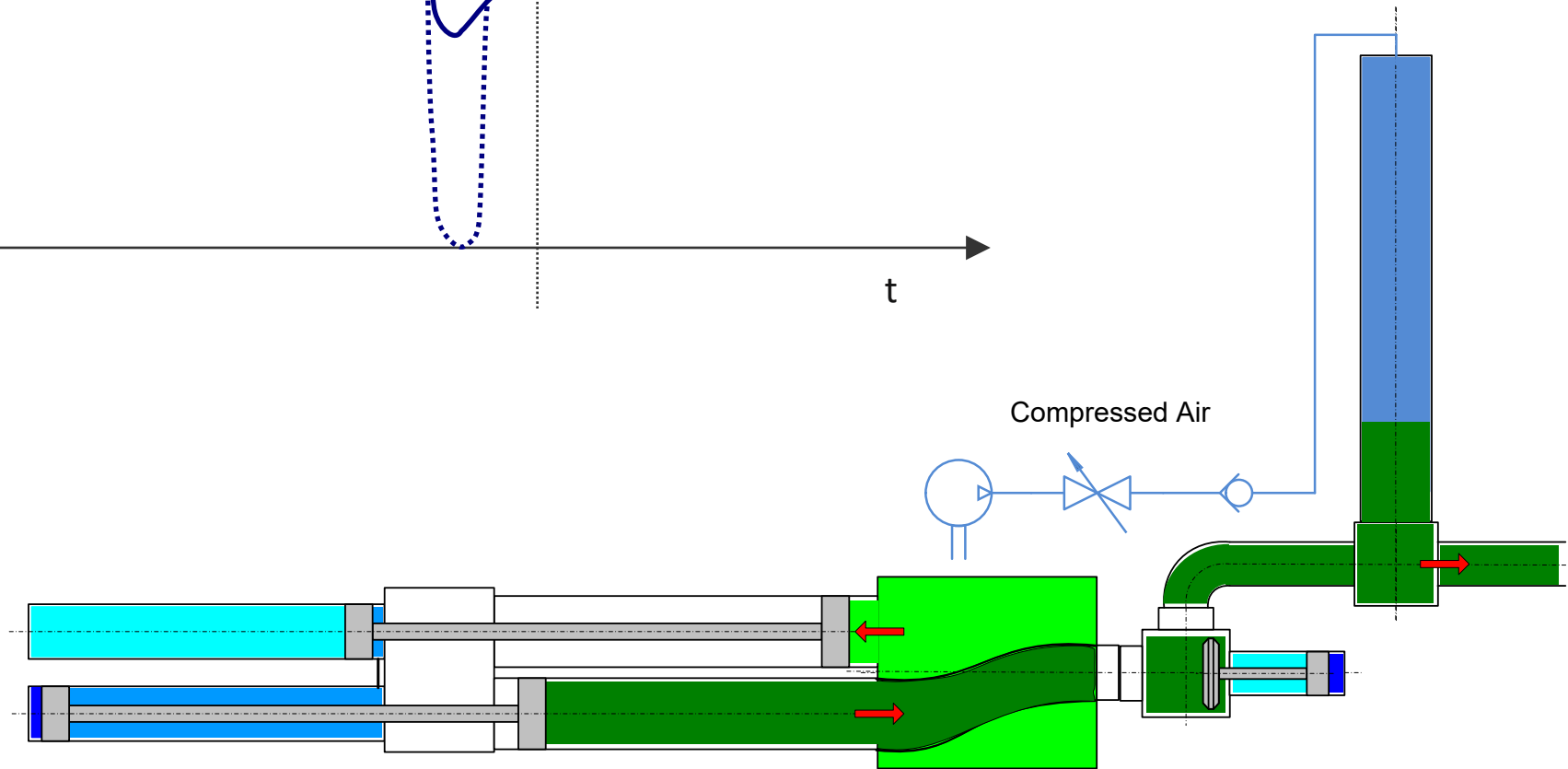
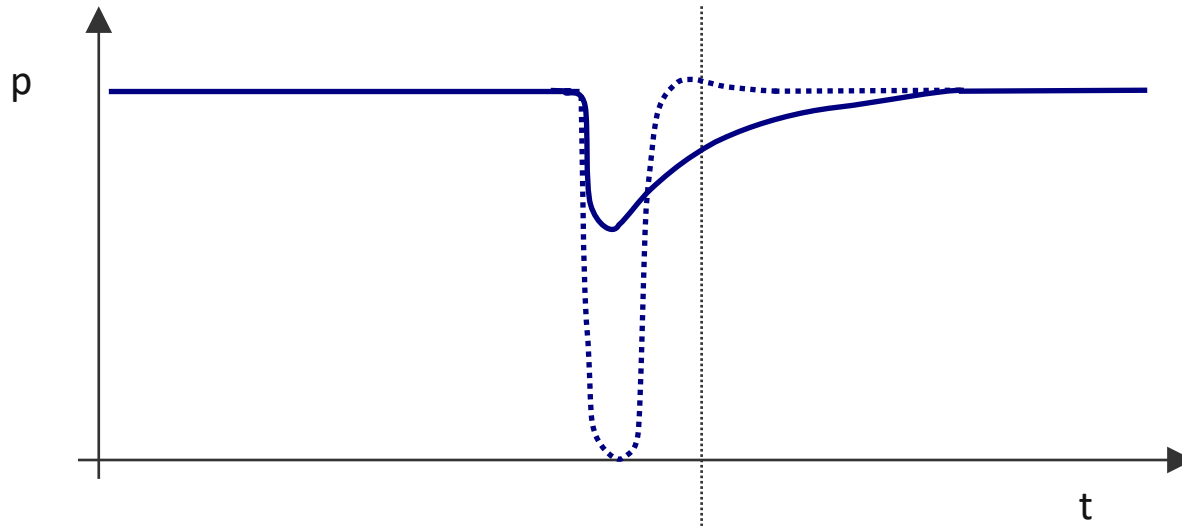

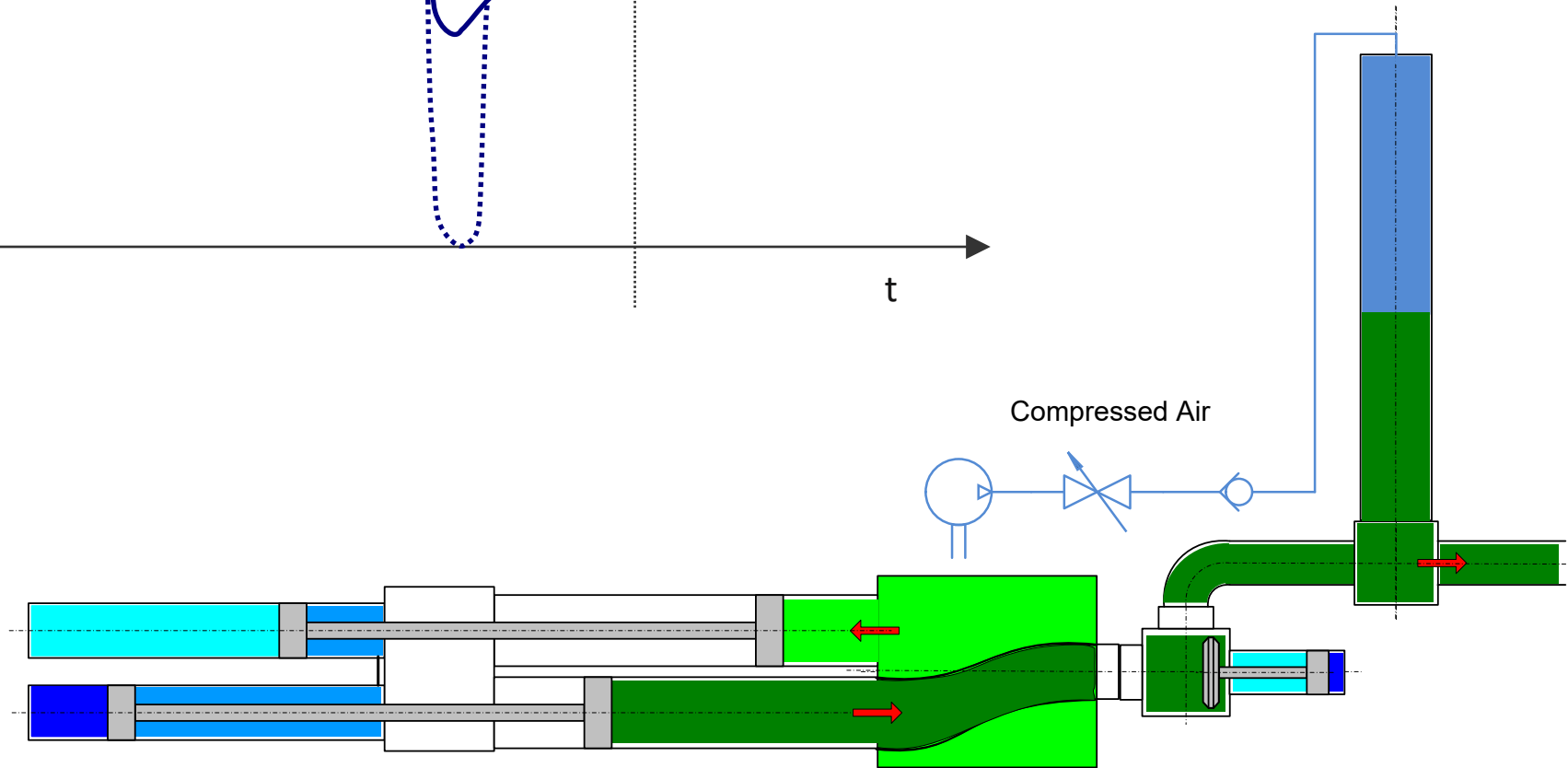
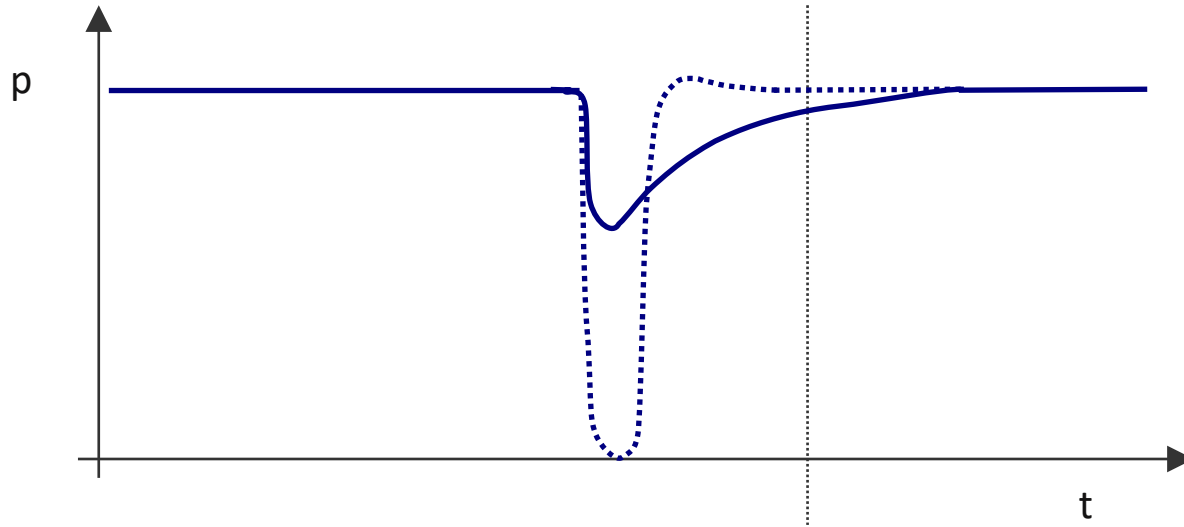

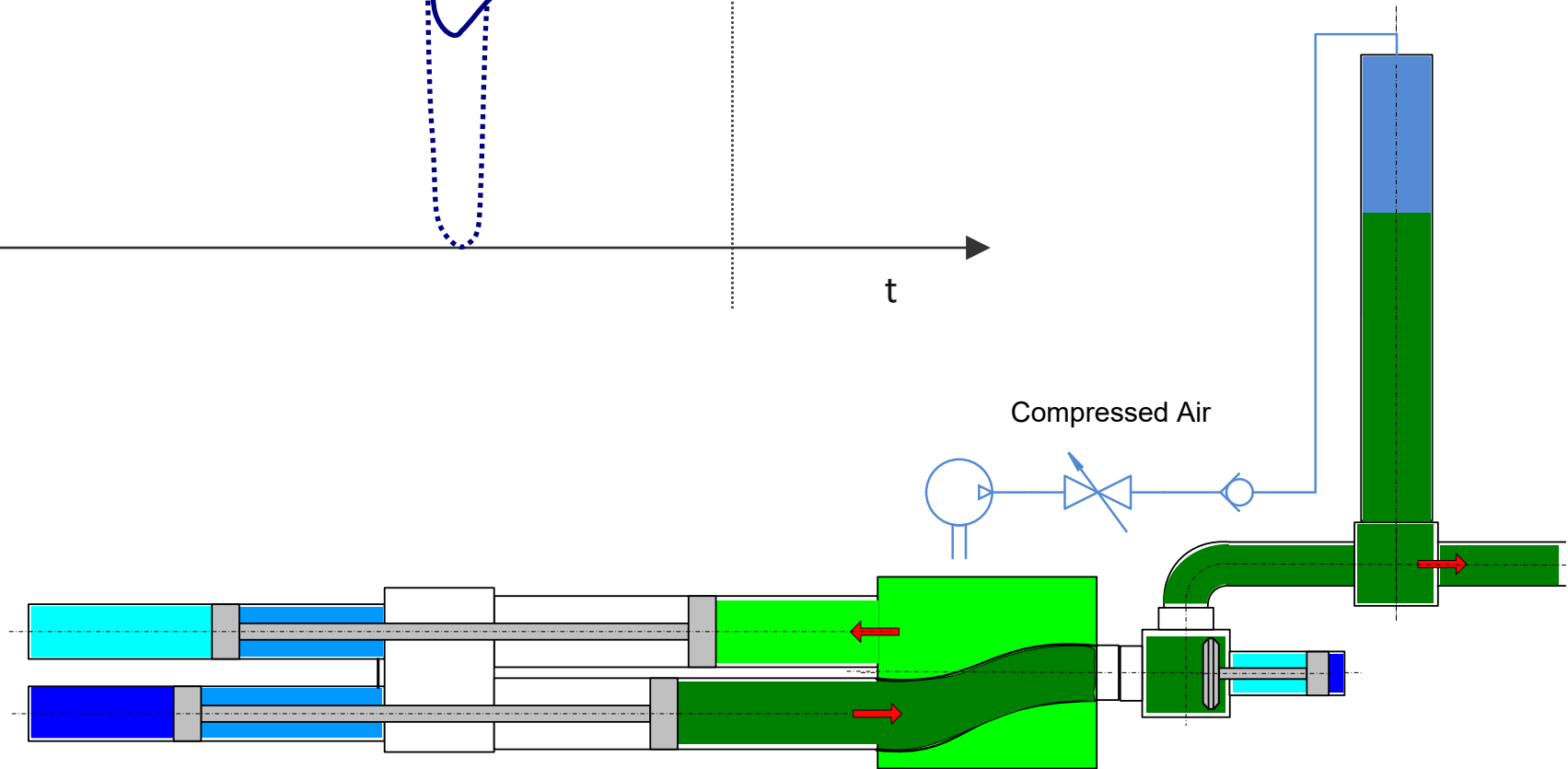
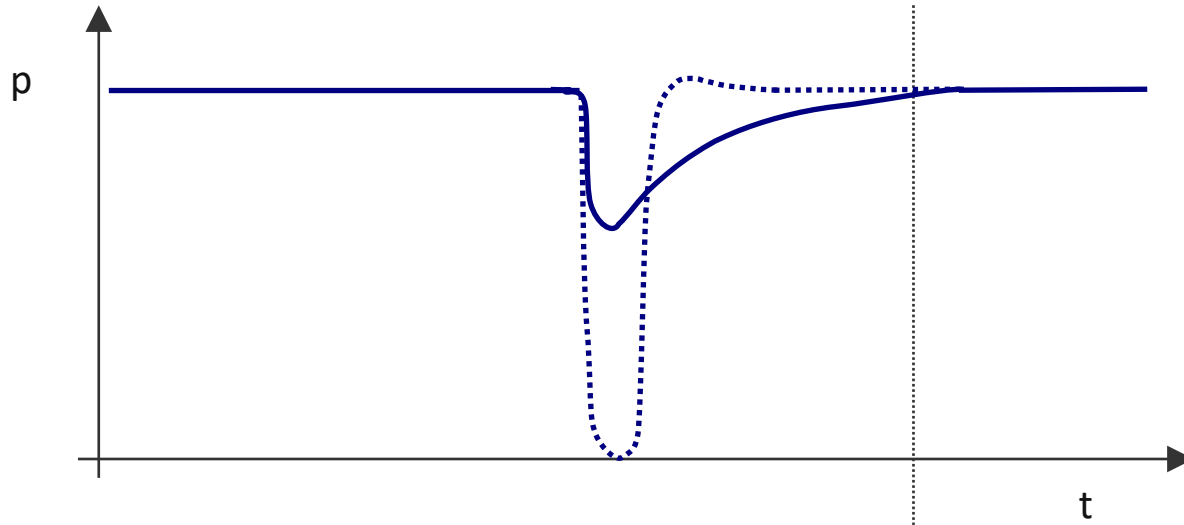

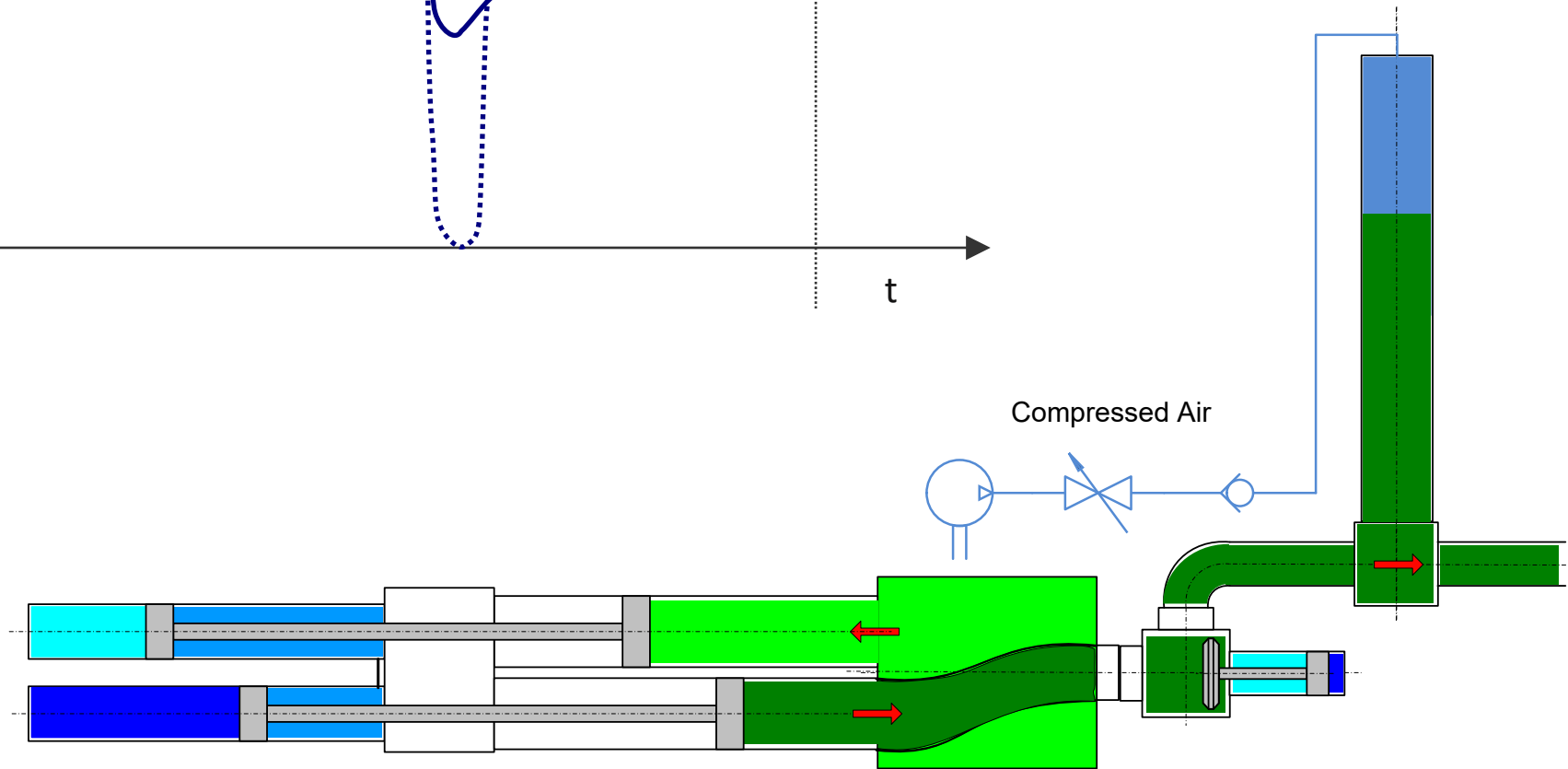
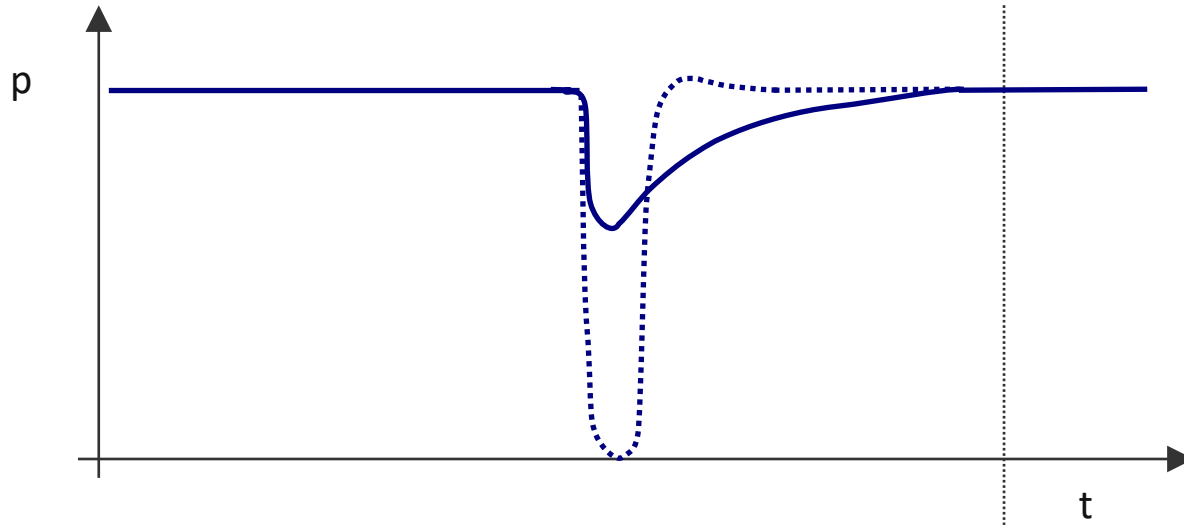

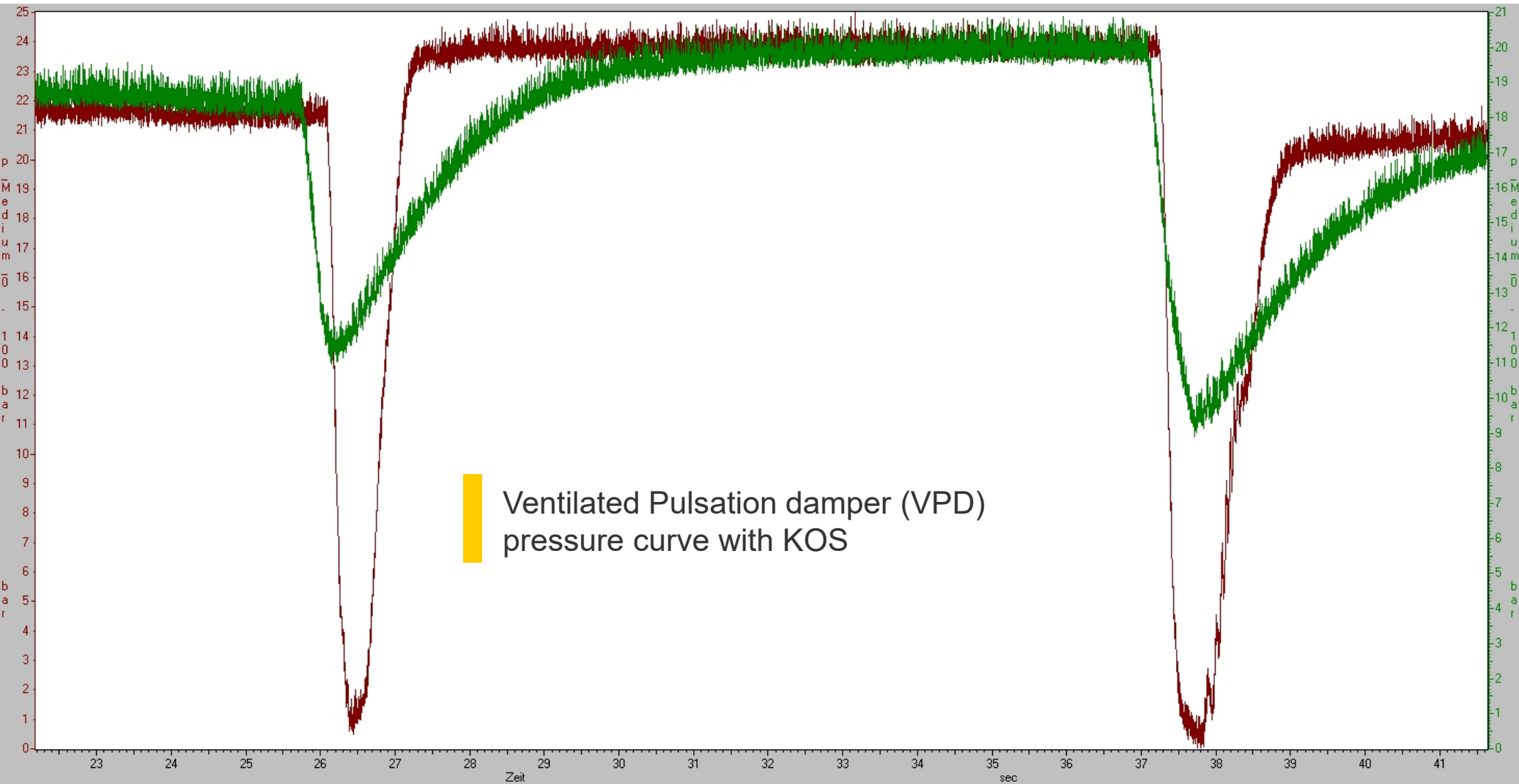

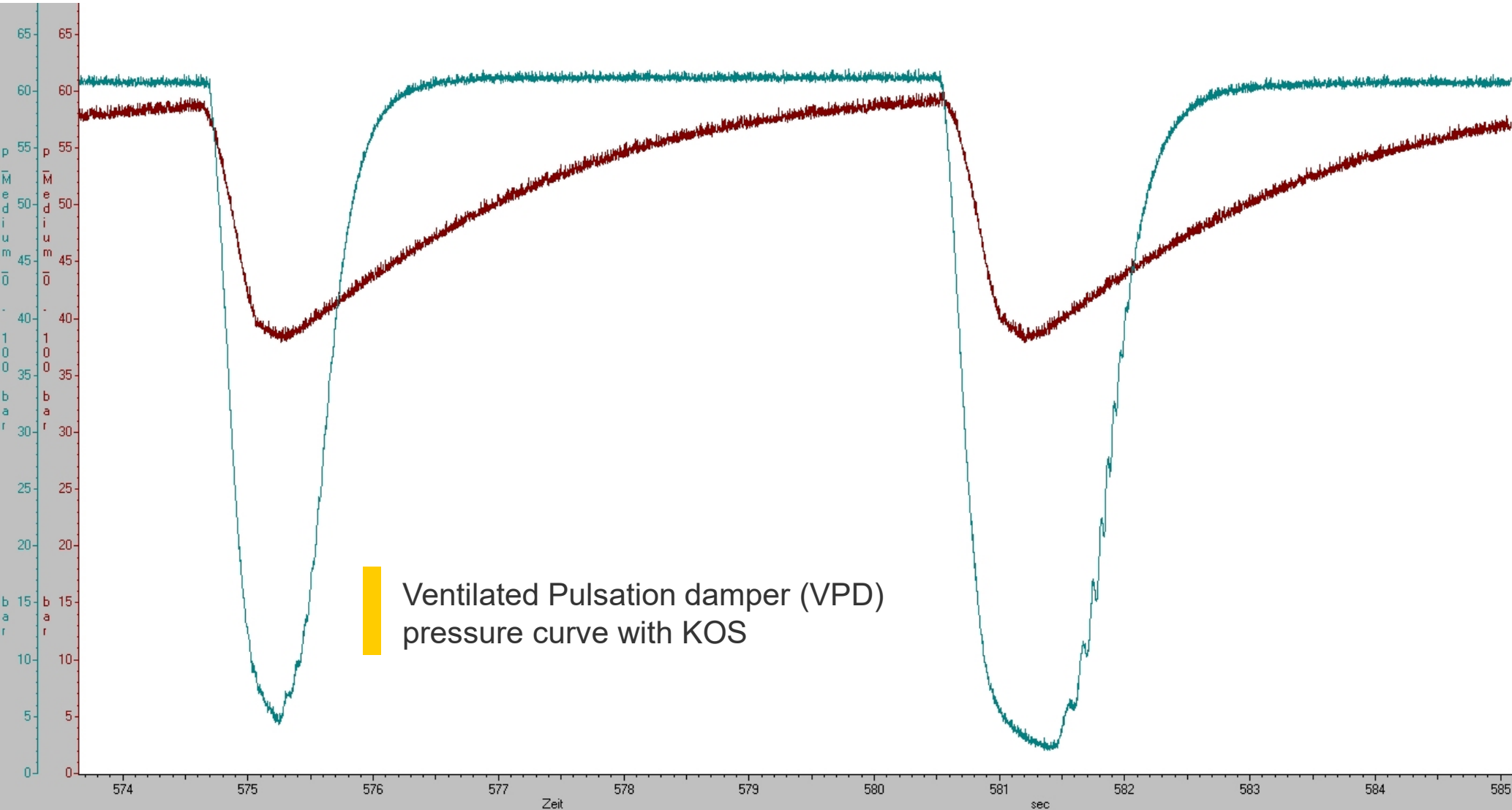

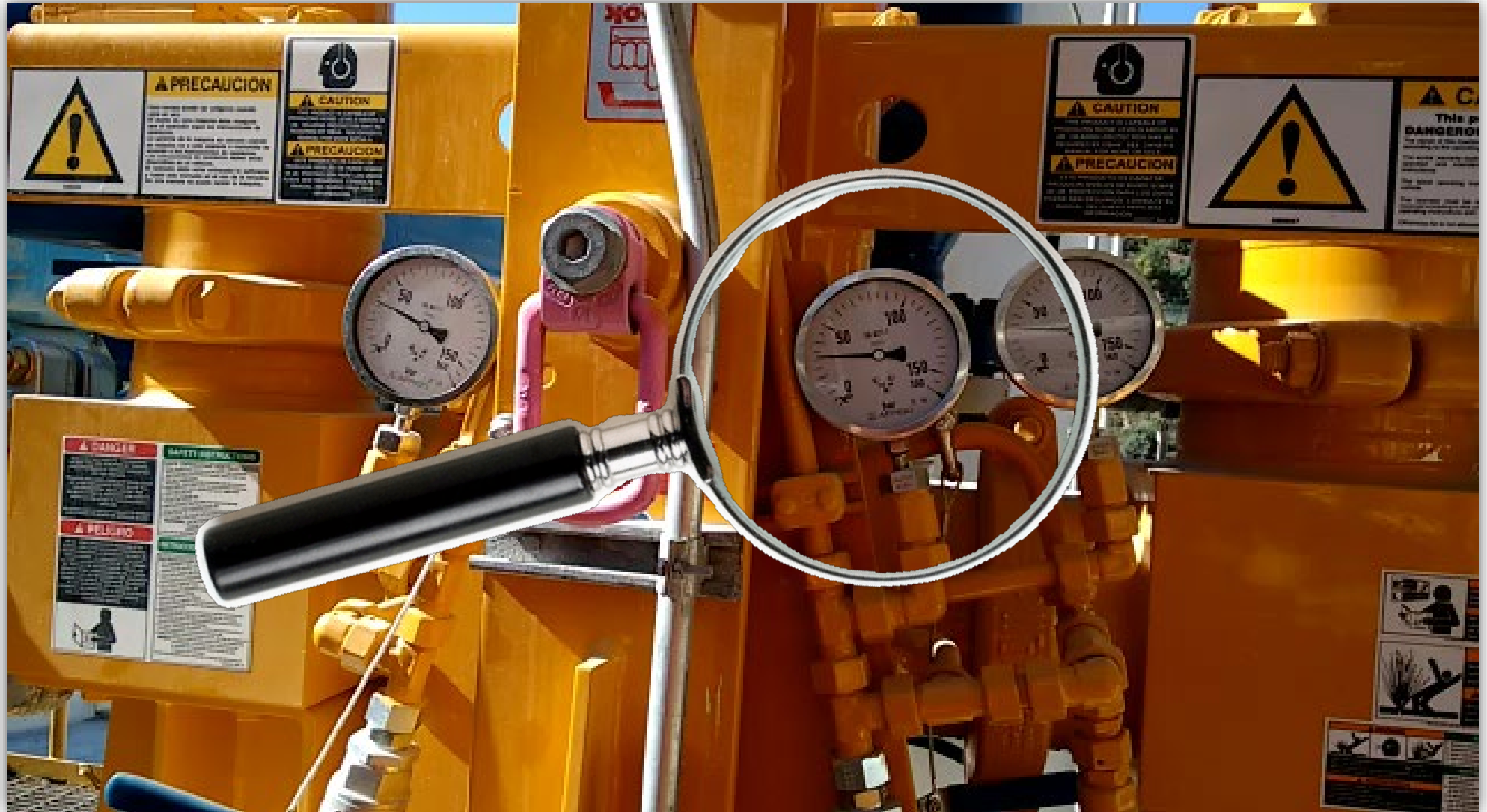





Advantages of the Ventilated Pulsation Damper (VPD)

- Compressed air is used as a spring and therefore **cheap operation costs**
- **No wear parts** (membrane) necessary
- **No permanent loss of energy**
(the compressor is only needed if the output or the pressure are changing)
- Easy cleaning and maintenance
- **Elimination of Water Hammers**
- Existing Plants can be updated very easily
- The VPD is working in different pressure levels without any manual adjustment

Conclusion and Comparison of the Systems

		HPD	VPD
Elimination of water hammers in the pipeline	✓	✓	✓
Can be used for hardening material (e.g. cemented paste)	✓	✓	✗
Suitable for continuous operation at 100 bar (1.450 psi)	✓	✓	✓
Suitable for continuous operation at 150 bar (2.175 psi)	✓	✗	✗
no membrane or other additional mechanical parts with a limited life time have to be installed in the system	✓	✗	✗
The System is working in different pressure levels without any adjustment	✓	✓	✓
System can be used for different pumping material within the same installation	✓	✓	✓
Easy cleaning and maintenance	✓	✓	✓
System can handle coarse material (e.g. 1/2" stones)	✗	✓	✓
working in different pressure levels without any manual adjustment	✓	✓	✓
Compressed air is used as dampening media and therefore cheap operation costs (no permanent loss of energy as the compressor is only needed if the output or the pressure are changing)	✗	✗	✓
Retrofit of existing Plants can be done very easily	✗	✓	✓

Putzmeister Pumps are designed to be operated without any need of additional Pulsation Dampening

Pulsation Dampening is an Option which makes the operation more comfortable.

The Advantages of dampening systems are:

- Elimination of “Water hammers”
- Expanding the lifetime of the pipeline as the wall thickness can be smaller
- Lower noise emission by the pipeline and therefore environmentally friendly
- Pipeline Supports can be minimized

DEVELOPED IN ORDER TO BE SUCCESSFUL

Our machines and plants offer maximum performance, quality and reliability.

A STRONG PARTNERSHIP

Cooperation based on trust. Our focus is always on the requirements and needs of our customers. Customer-orientation is our promise. We treat our partners with the utmost respect. We always act fairly and responsibly.

EXPERIENCE PAVES THE WAY

Our global team of highly qualified and motivated employees are constantly working on improving our products and services. In order to break new ground and set standards time and time again, we are continuously investing in research and development.

Putzmeister is a leading solution provider in the area of pumping, mixing and transportation of concrete, plaster and high-density substances.

With our parent company, Sany Heavy Industries, we are one of the global leaders in our industry.